

AUTOMATIC TRANSMISSION

	Page
DESCRIPTION.....	AT-2
OPERATION.....	AT-4
TROUBLESHOOTING.....	AT-9
General Notes.....	AT-9
General Troubleshooting.....	AT-10
Preliminary Check.....	AT-12
Mechanical System Tests.....	AT-14
Automatic Shift Schedule.....	AT-26
Neutral Start Switch.....	AT-28
O/D Solenoid (w/ Cruise Control System).....	AT-28
A/T Fluid Temperature Warning System.....	AT-29
ON-VEHICLE REPAIR.....	AT-30
Valve Body.....	AT-30
Throttle Cable.....	AT-33
REMOVAL AND INSTALLATION OF TRANSMISSION.....	AT-36
REMOVAL OF TRANSMISSION.....	AT-38
INSTALLATION OF TRANSMISSION.....	AT-44

AT

DESCRIPTION

GENERAL

The A440F and A442F automatic transmissions are the four-speed automatic transmission with a two-speed transfer, developed with the aim of producing an easy-driving 4WD vehicle. A lock-up mechanism is built into the torque converter.

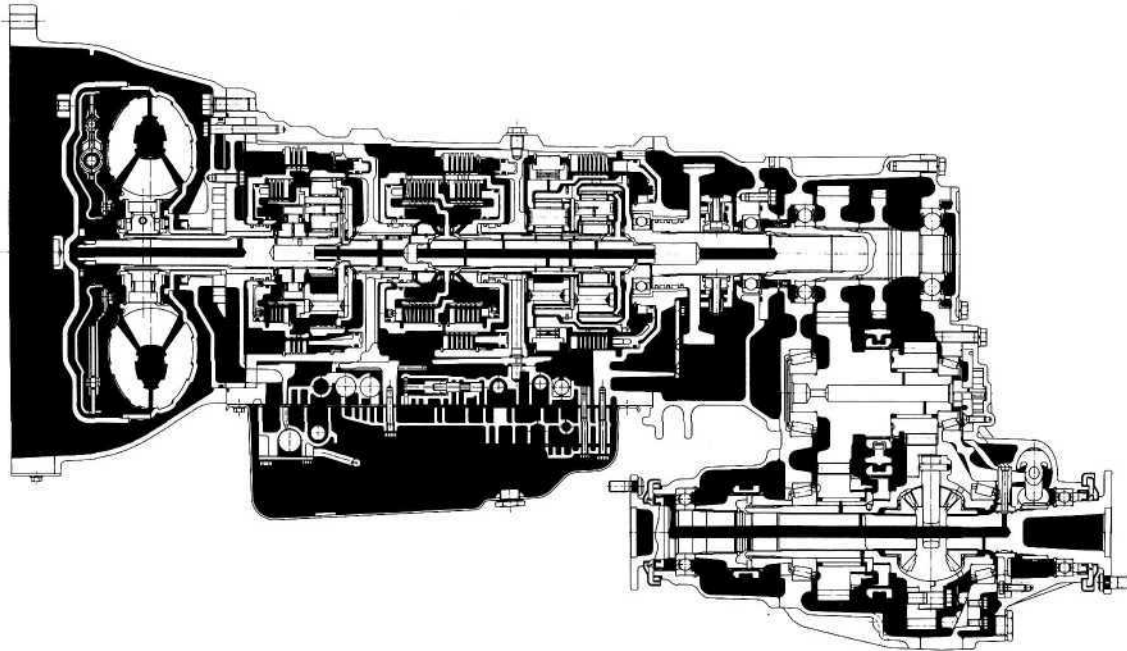

AT6021

The A440F and A442F transmissions are mainly composed of the torque converter, the overdrive (hereafter called O/D) planetary gear unit, 3-speed planetary gear unit, 2-speed transfer and the hydraulic control system.

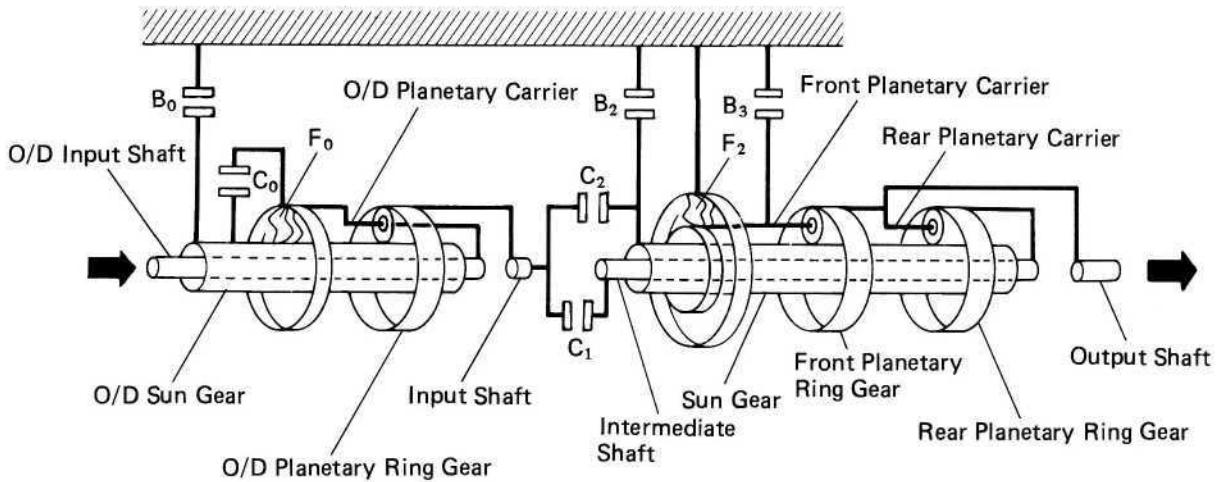

AT3917

General Specifications

Type of Transmission		A440F	A442F	
Type of Engine		3F, 3F-E, 1HZ	1HD-T	
Torque Converter	Stall Torque Ratio	1.88 : 1	2.0 : 1	
	Lock-Up Mechanism	Equipped	Equipped	
Gear Ratio	1st Gear	2.950	2.950	
	2nd Gear	1.530	1.530	
	3rd Gear	1.000	1.000	
	O/D Gear	0.717	0.765	
	Reverse Gear	2.678	2.678	
Number of Disc and Plates (Disc/Plate)	C ₁ Forward Clutch	6	6	
	C ₂ Direct Clutch	5	5	
	C ₀ O/D Direct Clutch	3	3	
	B ₂ 2nd Brake	4	5	
	B ₃ 1st and Reverse Brake	6	6	
	B ₀ O/D Brake	3	3	
Number of Sprags	F ₂ No.2 One-Way Clutch	46	46	
	F ₀ O/D One-Way Clutch	22	22	
Front Planetary Gear	No. of Sun Gear Teeth	28	28	
	No. of Pinion Gear Teeth	23	23	
	No. of Ring Gear Teeth	75	75	
Rear Planetary Gear	No. of Sun Gear Teeth	44	44	
	No. of Pinion Gear Teeth	20	20	
	No. of Ring Gear Teeth	83	83	
Overdrive Planetary Gear	No. of Sun Gear Teeth	35	31	
	No. of Pinion Gear Teeth	27	35	
	No. of Ring Gear Teeth	89	101	
ATF	Type		DEXRON® II	DEXRON® II
	Capacity litter (US qts, Imp. qts)	Total	15.0 (15.9, 13.2)	15.0 (15.9, 13.2)
		Drain and Refill	6.0 (6.3, 5.3)	6.0 (6.3, 5.3)

OPERATION

PLANETARY GEAR UNIT

The planetary gear unit is composed of three sets of planetary gears, three clutches which transmit power to the planetary gears, and three brakes and two one-way clutches which immobilize the planetary carrier and planetary sun gear.

Power from the engine transmitted the input shaft via the torque converter is then transmitted to the planetary gears by the operation of the clutches. By operation of the brakes and one-way clutches, either the planetary carrier or the planetary sun gear is immobilized, altering the speed of revolution of the planetary gear unit. Shift change is carried out by altering the combination of clutch and brake operation.

Each clutch and brake operates by hydraulic pressure; gear position is decided according to the throttle opening angle and vehicle speed, and shift change automatically occurs.

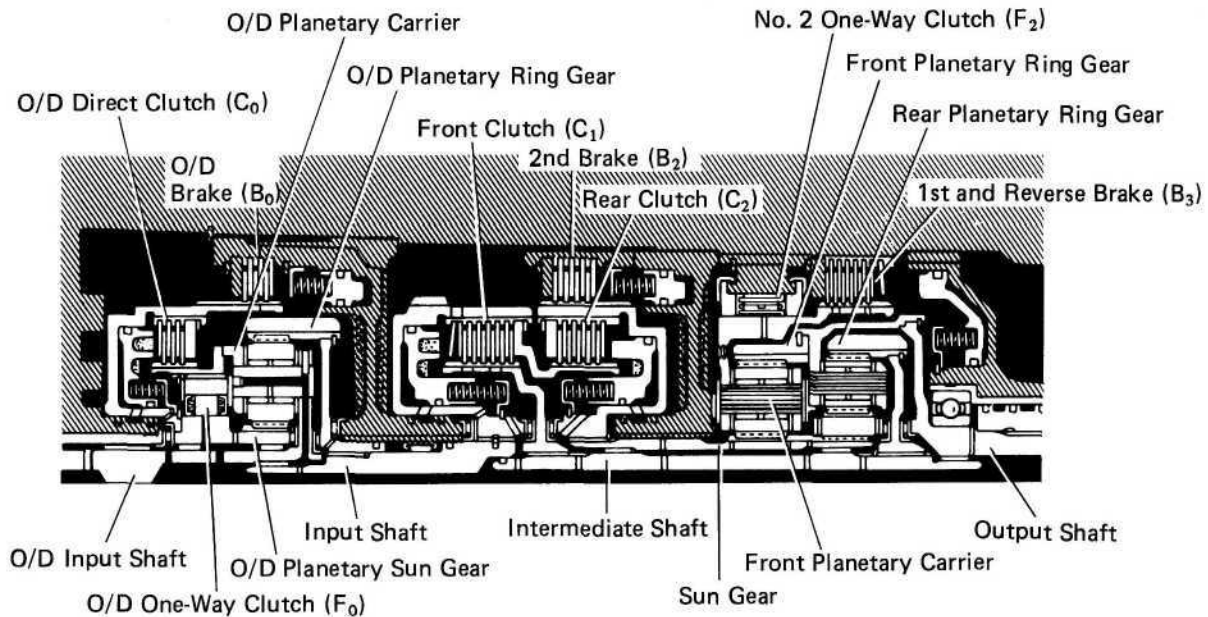

AT3918

OPERATION OF EACH ELEMENT

NOMENCLATURE	OPERATION
O/D Direct Clutch (C ₀)	Connects overdrive sun gear and overdrive carrier
O/D Brake (B ₀)	Prevents overdrive sun gear from turning either clockwise or counterclockwise
O/D One-Way Clutch (F ₀)	When transmission is being driven by engine, connects overdrive sun gear and overdrive carrier
Front Clutch (C ₁)	Connects input shaft and intermediate shaft
Rear Clutch (C ₂)	Connects input shaft and front & rear planetary sun gear
2nd Brake (B ₂)	Prevents front & rear planetary sun gear from turning either clockwise or counterclockwise
1st & Reverse Brake (B ₃)	Prevents front planetary carrier from turning either clockwise or counterclockwise
No.2 One-Way Clutch (F ₂)	Prevents front planetary carrier from turning counterclockwise

OPERATING CONDITION FOR EACH GEAR

○ Operating

Shift lever position	Gear position	C ₀	C ₁	C ₂	B ₀	B ₂	B ₃	F ₀	F ₂
P	Parking	○						○	
R	Reverse	○		○			○	○	
N	Neutral	○						○	
D	1st	○	○					○	○
	2nd		○			○		○	
	3rd	○	○	○				○	
	O/D		○	○	○				
3	1st	○	○					○	○
	2nd		○			○		○	
	3rd	○	○	○				○	
2	2nd	○	○			○		○	
L	1st	○	○				○	○	○

FUNCTION OF COMPONENTS

The conditions of operation for each gear position are shown on the following illustration:

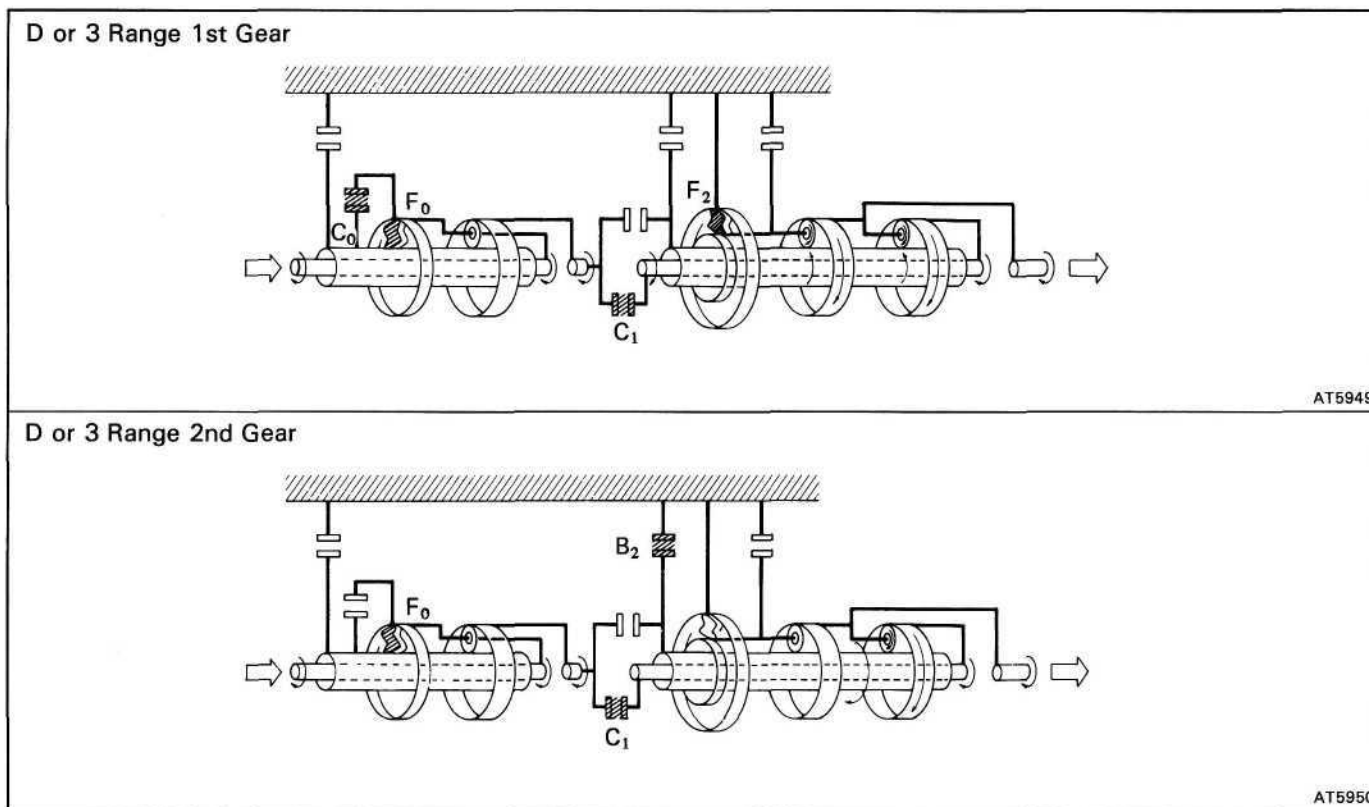

FUNCTION OF COMPONENTS (Cont'd)

D or 3 Range 3rd Gear

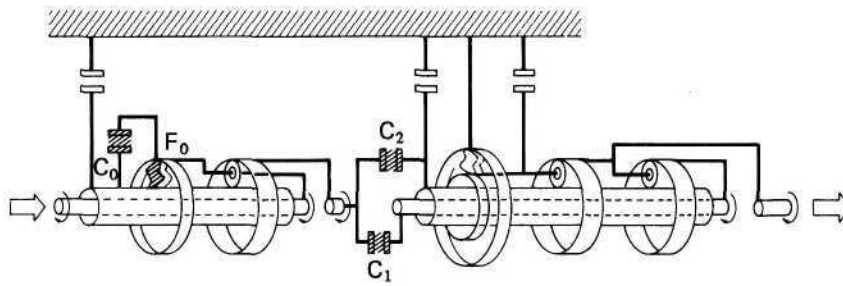

AT5951

D Range O/D

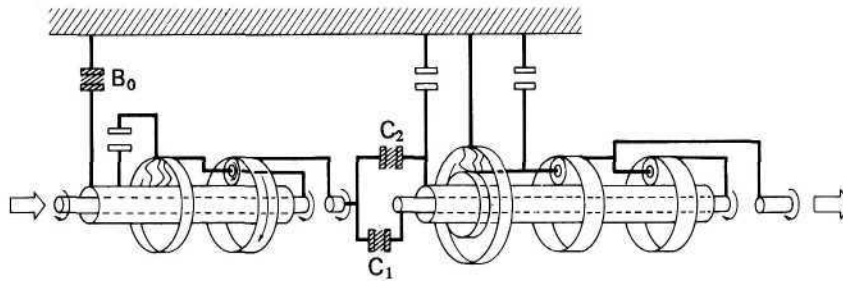

AT5952

2 Range 2nd Gear

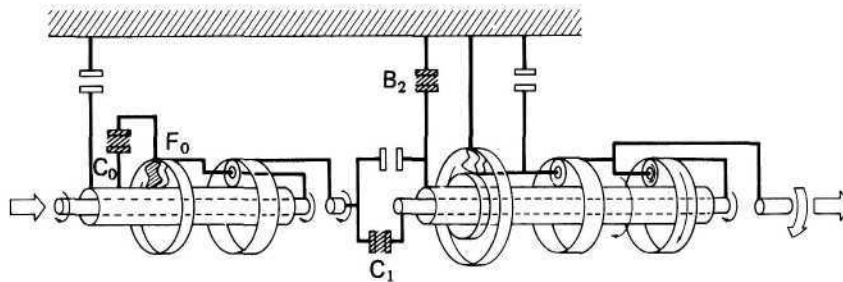

AT5953

L Range 1st Gear

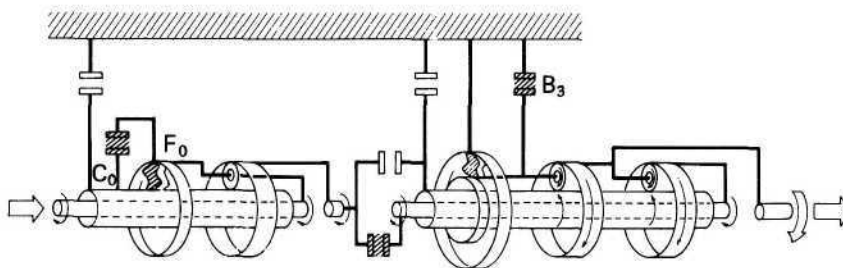

AT5954

R Range Reverse Gear

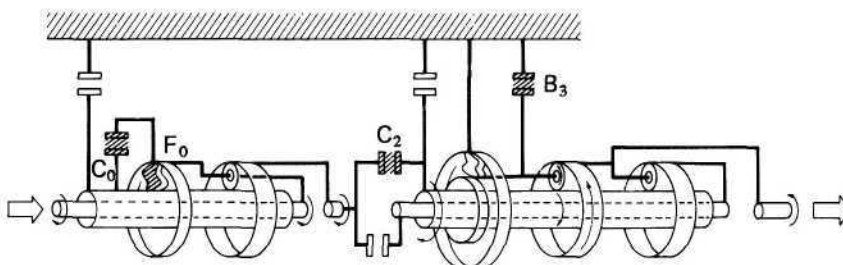

AT5955

Hydraulic Control System

The hydraulic control system is composed of the oil pump, the valve body, the solenoid valve, the accumulators, the clutches and brakes, as well as the fluid passages which connect all of these components.

Based on the hydraulic pressure created by the oil pump, the hydraulic control system governs the hydraulic pressure acting on the torque converter, clutches and brakes in accordance with the vehicle driving conditions.

There is a solenoid valve on the valve body.

The solenoid valve accompany with the cruise control system is turned on and off by signals from the CCS ECU to operate the 3-4 shift valve, and change the gear shift position.

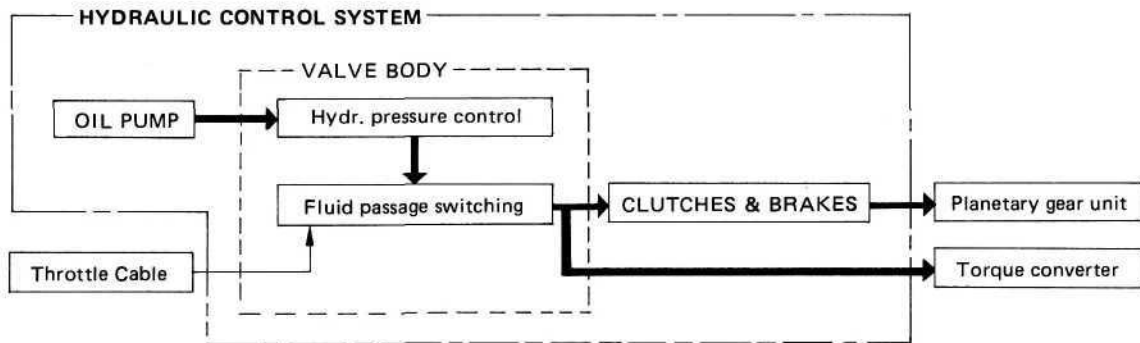

(w/ Cruise Control System)

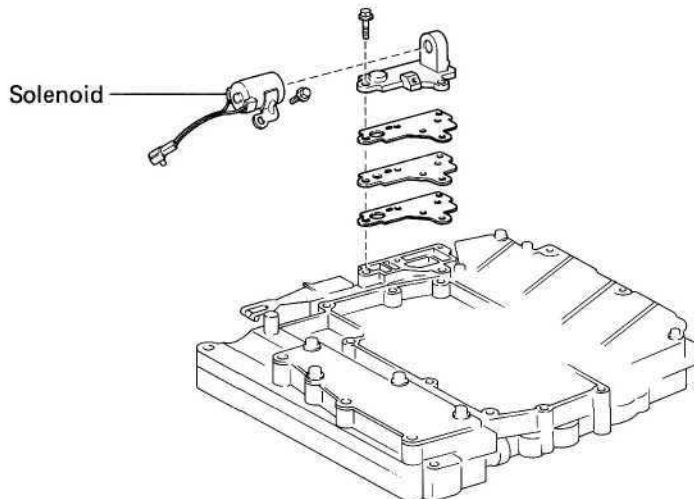
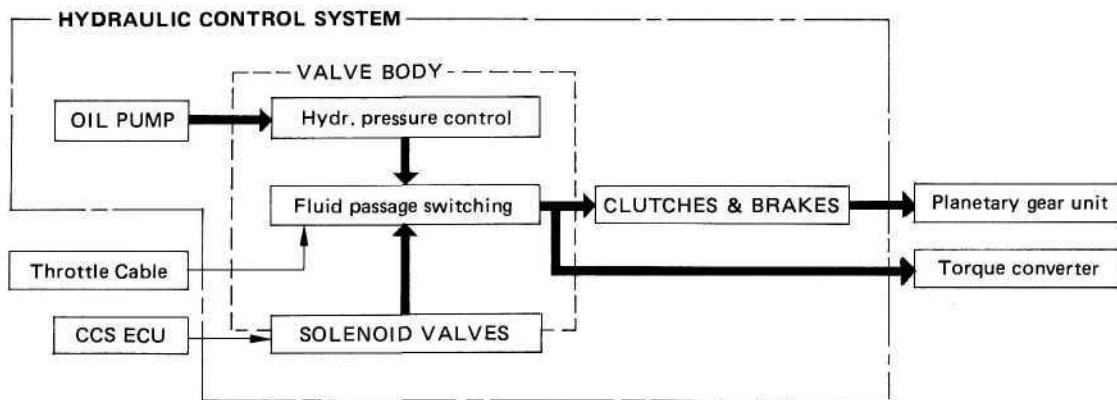

A.T. FLUID TEMPERATURE WARNING SYSTEM

The ECU detects the A/T fluid temperature by means of a fluid temperature sensor fitted to the union. The A/T fluid may become extremely hot when the vehicle is under an extreme load, as when driving on sand or climbing uphill. Should the fluid temperature increase above 150 °C (302 °F), the ECU lights the warning light located in the combination meter. The light goes off when the temperature falls below 120 °C (248 °F).

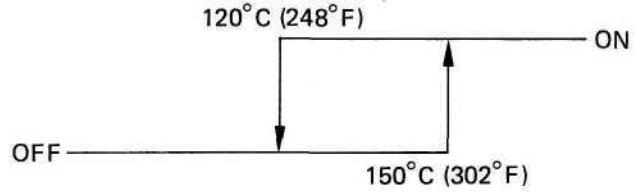
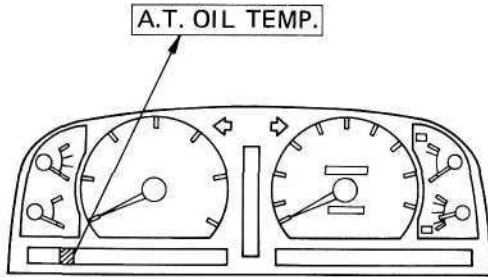

A.T. Fluid Temp.

AT6023

A.T.P. (Automatic Transmission Parking) INDICATOR

The propeller shaft and wheels are free even when the transmission shift lever is set to "P" as long as the transfer shift lever is in "neutral" position. The A.T.P. indicator lights up to warn the driver that the propeller shaft and wheels are not locked. If the A.T.P. indicator light goes on, the transfer shift lever should be shifted to out of "N" position.

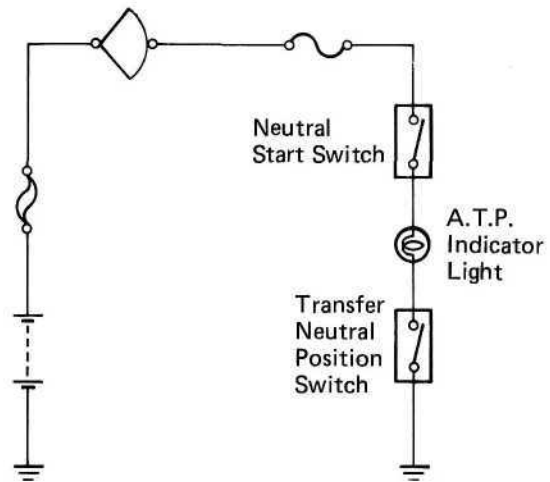
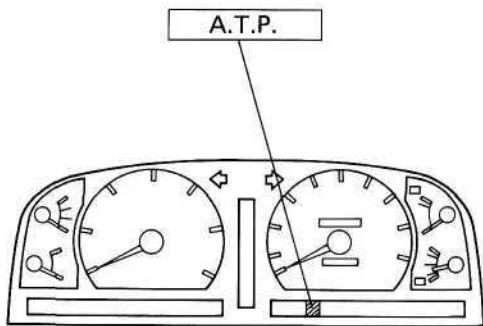

AT6024

AT3920

TROUBLESHOOTING

General Notes

1. Troubles occurring with the automatic transmission can be caused by either the engine or the transmission itself. These two areas should be distinctly isolated before proceeding with troubleshooting.
2. Troubleshooting should begin with the simplest operation, working up in order of difficulty, but first determine whether the trouble lies within the engine, electrical control or transmission.
3. Proceed with the inspection as follows:

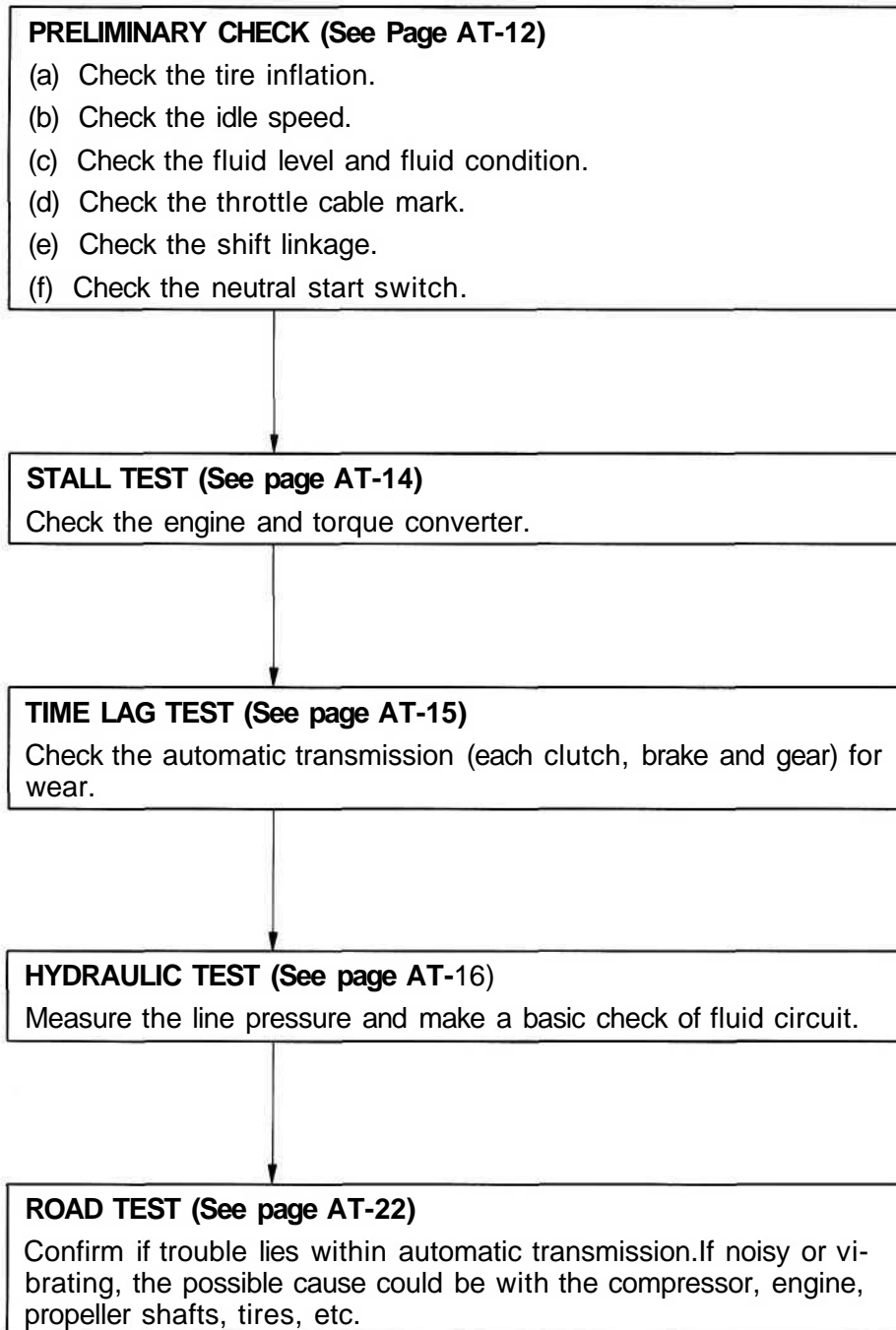

General Troubleshooting

Problem	Possible cause	Remedy	Page
Fluid discolored or smells burnt	Fluid contaminated Torque converter faulty Transmission faulty	Replace fluid Replace torque converter Disassemble and inspect transmission	AT-12 AT-37
Vehicle does not move in any forward range or reverse	Manual linkage out of adjustment Valve body or primary regulator faulty Parking lock pawl faulty Torque converter faulty Converter drive plate broken Oil pump intake strainer blocked Transmission faulty	Adjust linkage Inspect valve body Inspect parking lock pawl Replace torque converter Replace drive plate Clean strainer Disassemble and inspect transmission	AT-13 AT-29 AT-37 AT-37 AT-29
Shift lever position incorrect	Manual linkage out of adjustment Manual valve and lever faulty Transmission faulty	Adjust linkage Inspect valve body Disassemble and inspect transmission	AT-13 AT-29
Harsh engagement into any drive range	Throttle cable out of adjustment Valve body or primary regulator faulty Accumulator pistons faulty Transmission faulty	Adjust throttle cable Inspect valve body Inspect accumulator pistons Disassemble and inspect transmission	AT-13 AT-29
Delayed 1-2, 2-3 or 3-O/D up-shift, or down-shifts from O/D-3 or 3-2 and shifts back to O/D or 3	Throttle cable out of adjustment Throttle cable and cam faulty Governor faulty Valve body faulty	Adjust throttle cable Inspect throttle-cable and cam Inspect governor Inspect valve body	AT-13 AT-32 AT-29
Slips on 1-2, 2-3 or 3-O/D up-shift, or slips or shudders on acceleration	Manual linkage out of adjustment Throttle cable out of adjustment Valve body faulty Transmission faulty	Adjust linkage Adjust throttle cable Inspect valve body Disassemble and inspect transmission	AT-13 AT-13 AT-29
Drag, binding or tie-up of 1-2, 2-3 or 3-O/D up-shift	Manual linkage out of adjustment Valve body faulty Transmission faulty	Adjust linkage Inspect valve body Disassemble and inspect transmission	AT-13 AT-29

General Troubleshooting (Cont'd)

Problem	Possible cause	Remedy	Page
No lock-up	Valve body faulty Torque converter faulty Transmission faulty	Inspect valve body Replace torque converter Disassemble and inspect transmission	AT-29 AT-44
Harsh down-shift	Throttle cable out of adjustment Throttle cable and cam faulty Accumulator pistons faulty Valve body faulty Transmission faulty	Adjust throttle cable Inspect throttle cable and cam Inspect accumulator pistons Inspect valve body Disassemble and inspect transmission	AT-13 AT-32 AT-29
No down-shift when coasting	Governor faulty Valve body faulty	Inspect governor Inspect valve body	AT-29
Down-shift occurs too quickly or too late while coasting	Throttle cable out of adjustment Governor faulty Valve body faulty Transmission faulty	Adjust throttle cable Inspect governor Inspect valve body Disassemble and inspect transmission	AT-13 AT-29
No O/D-3 , 3-2 or 2-1 kick-down	Throttle cable out of adjustment Governor faulty Valve body faulty	Adjust throttle cable Inspect governor Inspect valve body	AT-13 AT-29
No engine braking in 2 or L range	Valve body faulty Transmission faulty	Inspect valve body Disassemble and inspect transmission	AT-29
Vehicle does not hold in P	Manual linkage out of adjustment Parking lock pawl cam and spring faulty	Adjust linkage Inspect cam and spring	AT-13

Preliminary Check

1. CHECK FLUID LEVEL

HINT:

- The vehicle must have driven so that the engine and transmission are at normal operating temperature.

(Fluid temperature: 70 - 80 °C or 158 - 176 °F)

- Only use the COOL range on the dipstick as a rough reference when the fluid is replaced or the engine does not run.

- Park the vehicle on a level surface, set the parking brake.
- With the engine idling, shift the shift lever into all positions from P to L position and return to P position.
- Pull out the transmission dipstick and wipe it clean.
- Push it back fully into the tube.
- Pull it out and check that the fluid level is on the HOT range.

If the level is at the low side, add fluid.

Fluid type: ATFDEXRON®II

NOTICE: Do not overfill.

2. CHECK FLUID CONDITION

If the fluid smells burnt or is black, replace it in the following procedure.

- Remove the drain plug and drain the fluid.
- Reinstall the drain plug securely.

Torque: 280 kg-cm (20 ft-lb, 27 N-m)

- With the engine OFF, add new fluid through the oil filler tube.

Fluid type: ATF DEXRON® II

Capacity:

Total

w/o Oil cooler

15.0 liters (15.9 US qts, 13.2 Imp. qts)

w/ Oil cooler

15.4 liters (16.3 US qts, 13.6 Imp. qts)

Drain and refill

6.0 liters (6.3 US qts, 5.3 Imp. qts)

- Start the engine and shift the shift lever into all positions from P to L position and then shift into P position.
- With the engine idling, check the fluid level. Add fluid up to the COOL level on the dipstick.
- Check the fluid level with the normal operating temperature (70 — 80 °C or 158 - 176 °F) and add as necessary.

NOTICE: Do not overfill.

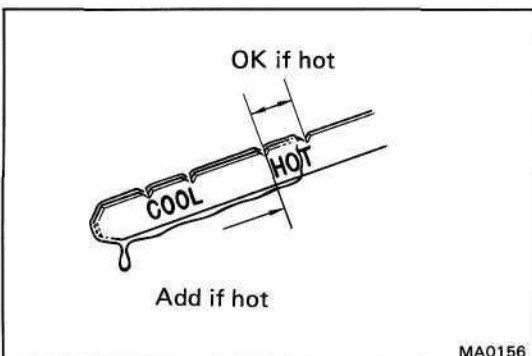
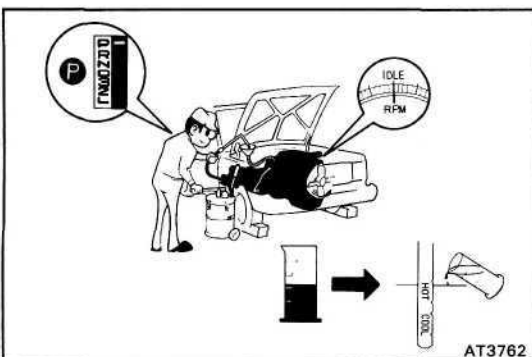
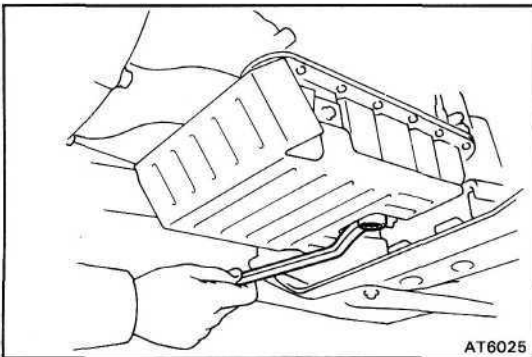
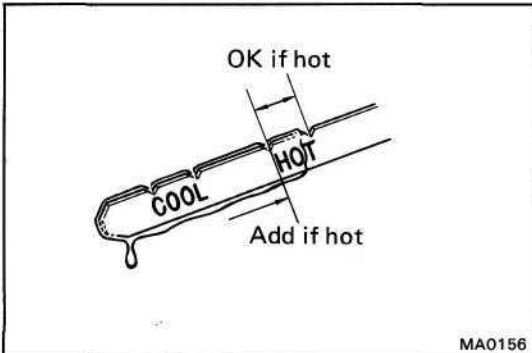

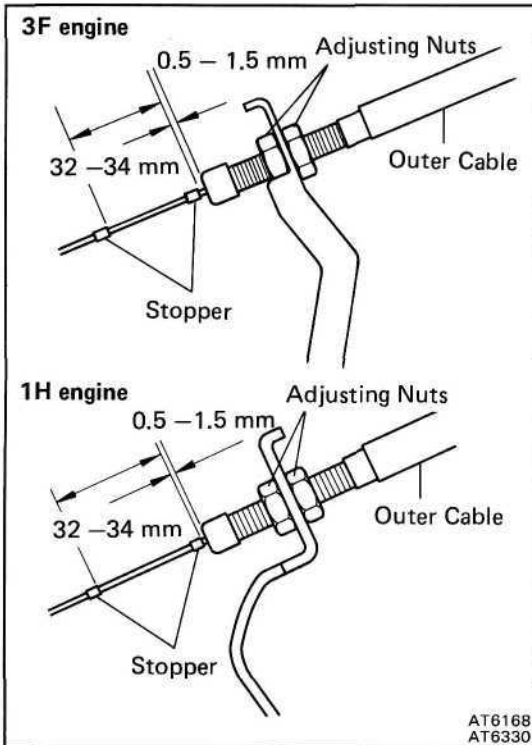

3. INSPECT THROTTLE CABLE

- (a) Check that the throttle cable is installed correctly and not bent.
- (b) With the throttle valve fully closed, measure the distance between the end of the boot and stopper on the cable.

Standard distance:

Fully closed 0.5 — 1.5 mm
(0.020 - 0.059 in.)
Fully opened 32 — 34 mm
(1.260 - 1.339 in.)

If the distance is not standard, adjust the cable by the adjusting nuts.

4. INSPECT TRANSMISSION SHIFT LEVER POSITION

When shifting the shift lever from the N position to other positions, check that the lever can be shifted smoothly and accurately to each position and that the position indicator correctly indicates the position.

If the indicator is not aligned with the correct position, carry out the following adjustment procedures.

- (a) Loosen the nut on the control rod.
- (b) Push the control shaft lever fully toward the rear of the vehicle.
- (c) Return the control shaft lever two notches to N position.
- (d) Set the shift lever to N position.
- (e) While holding the shift lever lightly toward the R position side, tighten the control rod nut.
- (f) Start the engine and make sure that the vehicle moves forward when shifting the lever from the N to D position and reverse when shifting it to the R position.

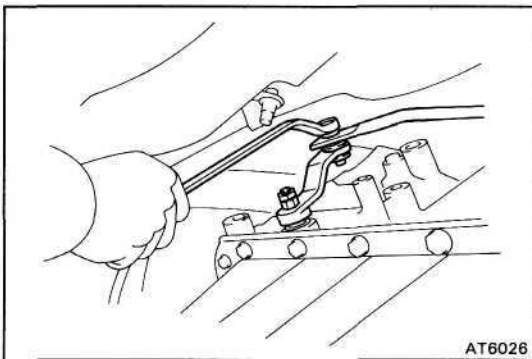

5. INSPECT NEUTRAL START SWITCH

Check that the engine can be started with the shift lever only in the N or P position, but not in other positions.

If not as started above, carry out the following adjustment procedures.

- (a) Loosen the neutral start switch bolts and set the shift lever to the N position.
- (b) Align the groove and neutral basic line.
- (c) Hold in position and tighten the bolts.

Torque: 130 kg-cm (9 ft-lb, 13 N-m)

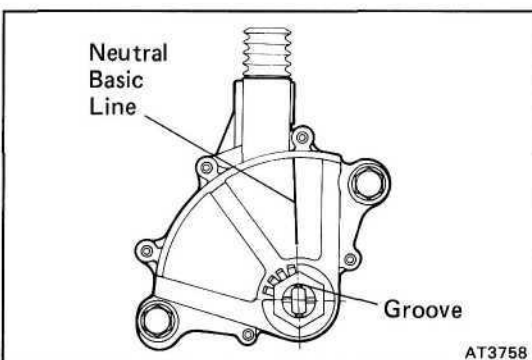

6. INSPECT IDLE SPEED (N RANGE)

Connect tachometer test probe to the check connector terminal IG Q>, inspect the idle speed.

Idle speed: 650 rpm

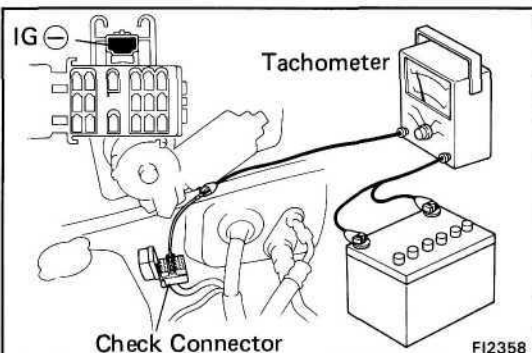

Mechanical System Tests

STALL TEST

The object of this test is to check the overall performance of the transmission and engine by measuring the stall speeds in the D and R ranges.

NOTICE:

- Perform the test at normal operating fluid temperature (50 - 80 °C or 122 - 176 °F).
- Do not continuously run this test longer than 5 seconds.

MEASURE STALL SPEED

- Warm up the transmission fluid.
- Chock the front and rear wheels.
- Connect a tachometer to the engine.
- Fully apply the parking brake.
- Step down strongly on the brake pedal with your left foot.
- Start the engine.
- Shift into the D range. Step all the way down on the accelerator pedal with your right foot. Quickly read the stall speed at this time.

Stall speed: 3F Engine 1,850 ± 150 rpm

1H Engine 1,900 ± 150 rpm

- Perform the same test in R range.

EVALUATION

- If the stall speed is the same for both ranges but lower than specified value:
 - Engine output may be insufficient
 - Stator one-way clutch is not operating properly

HINT: If more than 600 rpm below the specified value, the torque converter could be faulty.

- If the stall speed in D range is higher than specified:
 - Line pressure too low
 - Front clutch slipping
 - No.2 one-way clutch not operating properly
 - O/D one-way clutch not operating properly
- If the stall speed in R range is higher than specified:
 - Line pressure too low
 - Rear clutch slipping
 - First and reverse brake slipping
 - O/D one-way clutch not operating properly
- If the stall speed in both R and D ranges are higher than specified:
 - Line pressure too low
 - Improper fluid level
 - O/D one-way clutch not operating properly

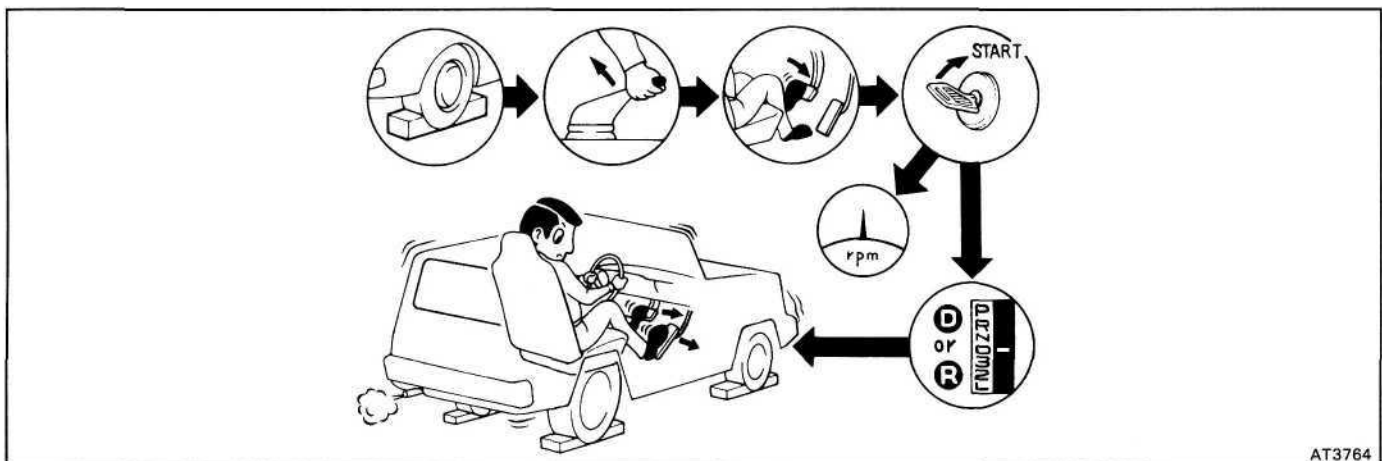

TIME LAG TEST

If the shift lever is shifted while the engine is idling, there will be a certain time lapse or lag before the shock can be felt. This is used for checking the condition of the O/D direct clutch, front clutch, rear clutch and first and reverse brakes.

NOTICE:

- Perform the test at normal operating fluid temperature (50 — 80 °C or 122 — 176 °F)
- Be sure to allow one minute intervals between tests.
- Make three measurements and take the average value.

MEASURE TIME LAG

- (a) Fully apply the parking brake.
- (b) Start the engine and check the idle speed.

Idle speed: 3F engine 750 rpm 1HZ engine 710 rpm
 3F-E engine 650 rpm 1HD-T engine 800 rpm

- (c) Shift the shift lever from N to D position. Using a stop watch, measure the time it takes from shifting the lever until the shock is felt.

Time lag: Less than 0.7 seconds

- (d) In same manner, measure the time lag N -> R.

Time lag: Less than 1.2 seconds

EVALUATION

- (a) If N -> D time lag is longer than specified:
 - Line pressure too low
 - Front clutch worn
 - O/D one-way clutch not operating properly
- (b) If N -> R time lag is longer than specified:
 - Line pressure too low
 - Rear clutch worn
 - First and reverse brake worn
 - O/D one-way clutch not operating properly

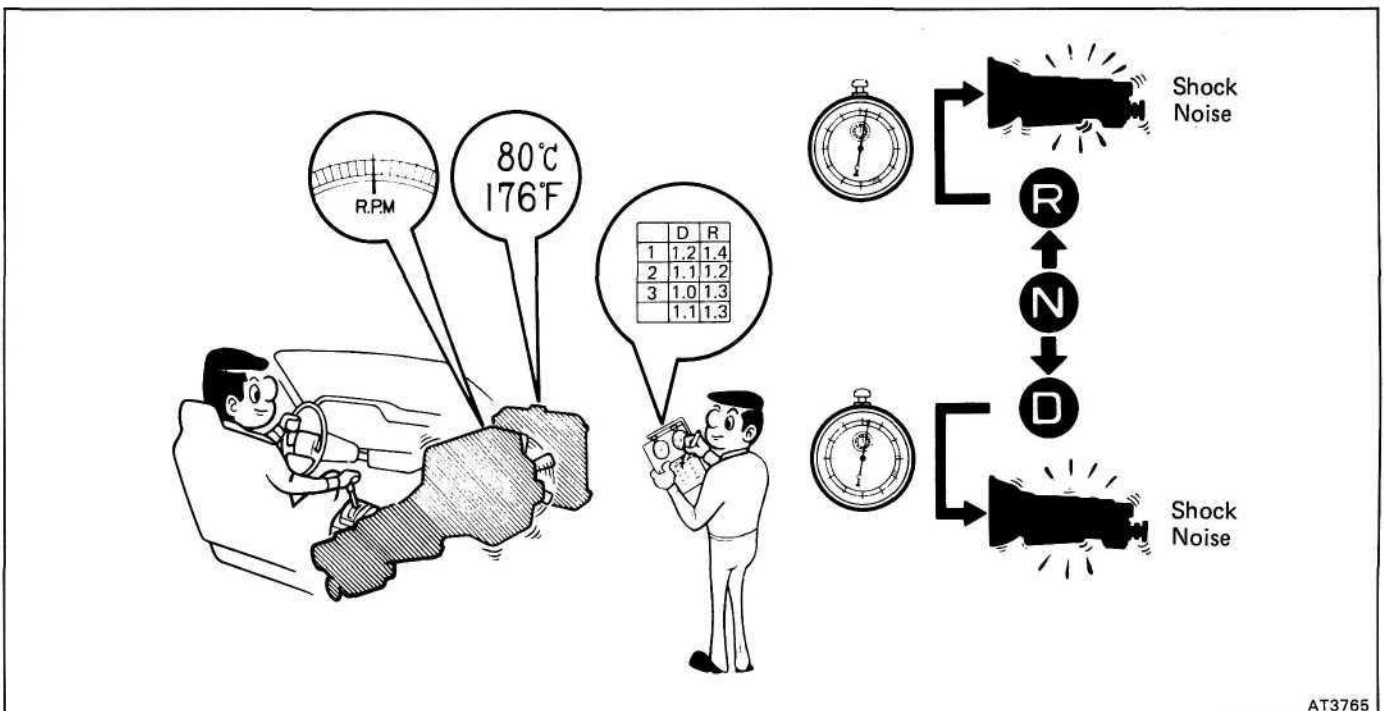

HYDRAULIC TEST

1. MEASURE LINE PRESSURE

NOTICE: Perform the test at normal operating fluid temperature (50 — 80 °C or 122 — 176 °F)

- (a) Warm up the transmission fluid.
- (b) Remove the transmission case test plug and connect the hydraulic pressure gauge.
SST 09992-00094 (Oil pressure gauge)
- (c) Fully apply the parking brake and chock the four wheels.
- (d) Start the engine and check idling rpm.
- (e) Step down strongly on the brake pedal with your left foot and shift into D range.
- (f) Measure the line pressure when the engine is idling.
- (g) Press the accelerator pedal all the way down. Quickly read the highest line pressure when engine speed reaches stall speed.
- (h) In the same manner, perform the test in R range.

(A440F)

kg/cm² (psi, kPa)

D range		R range	
Idling	Stall	Idling	Stall
3.7–4.3 (53–61, 363–422)	11.1–13.6 (158–193, 1,089–1,344)	4.5–5.5 (64–78, 441–539)	14.0–17.0 (199–242, 1,373–1,677)

(A442F)

kg/cm² (psi, kPa)

D range		R range	
Idling	Stall	Idling	Stall
4.4–5.2 (63–74, 431–510)	9.9–12.5 (141–178, 971–1,226)	6.5–8.6 (92–122, 637–843)	16.4–18.9 (233–269, 1,608–1,853)

If the measured pressures are not up to specified values, recheck the throttle cable adjustment and perform a retest.

EVALUATION

- (a) If the measured values at all ranges are higher than specified:
 - Throttle cable out of adjustment
 - Throttle valve defective
 - Regulator valve defective
- (b) If the measured values at all ranges are lower than specified:
 - Throttle cable out of adjustment
 - Throttle valve defective
 - Regulator valve defective
 - Oil pump defective
 - O/D direct clutch defective
- (c) If pressure is low in the D range only:
 - D range circuit fluid leakage
 - Front clutch defective
- (d) If pressure is low in the R range only:
 - R range circuit fluid leakage
 - Rear clutch defective
 - First and reverse brake defective

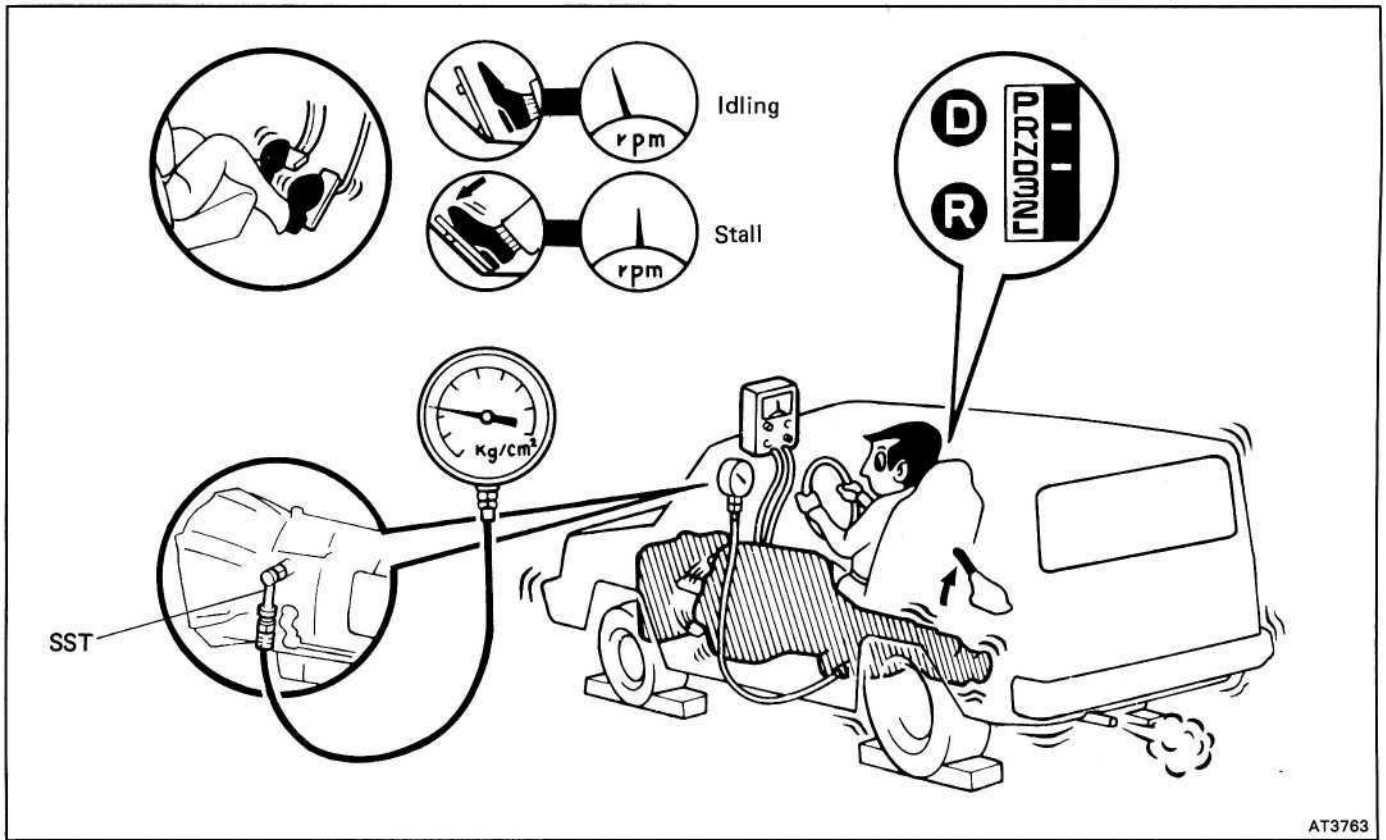

2. MEASURE GOVERNOR PRESSURE

NOTICE:

- Perform the test at normal operating fluid temperature (50 — 80 °C or 122 — 176 °F).
- Measurement can be made with a 1,000 rpm test, but if tests are to be made at 1,800 rpm and 3,500 rpm, it would be safer to do it on road or using a chassis dynamometer because an on-stand test could be hazardous.

- Warm up the transmission fluid.
- (Part-time) Shift the transfer shift lever to the "H2" position.
(Full-time) Lock the center differential.
- (Part-time) Chock the front wheels.
(Full-time) Remove front propeller shaft.
- (Part-time) Jack up rear of the vehicle and support it on stands.
(Full-time) Jack up the vehicle and support it on stands.
- Remove the transmission case test plug and connect the hydraulic pressure gauge.
SST 09992-00094 (Oil pressure gauge)
- Check that the parking brake is not applied.
- Start the engine.
- Shift into the D range and measure the governor pressure at the speeds specified in the table.

[Australia]

(3F-E Engine)

Output shaft rpm	Vehicle speed (Reference) km/h (mph)		Governor pressure kg/cm ² (psi, kPa)
	Tire size		
	7.50R16-6	265/75R-15	
1,000	35 (22)	34 (21)	0.8 — 1.2 (11 — 17, 78 — 118)
1,800	64 (40)	61 (38)	2.0 — 2.4 (28 — 34, 196 — 235)
3,500	124 (77)	118 (74)	5.7 — 6.3 (81 — 90, 559 — 618)

(1HD-T Engine)

Output shaft rpm	Vehicle speed (Reference) km/h (mph)		Governor pressure kg/cm ² (psi, kPa)
	Tire size		
	7.50R16-6	265/75R-15	
1,000	35 (22)	34 (21)	1.0 — 1.4 (14 — 20, 98 — 137)
1,800	64 (40)	61 (38)	2.3 — 2.9 (33 — 41, 226 — 284)
3,500	124 (77)	118 (74)	5.7 — 6.3 (81 — 90, 559 — 618)

[Europe]

(3F-E Engine)

Output shaft rpm	Vehicle speed (Reference) km/h (mph)		Governor pressure kg/cm ² (psi, kPa)
	Tire size		
	215/80R-16	265/75R-15	
1,000	33 (20)	34 (21)	0.8 — 1.2 (11 — 17, 78 — 118)
1,800	59 (36)	61 (38)	2.0 — 2.4 (28 — 34, 196 — 235)
3,500	114 (71)	118 (74)	5.7 — 6.3 (81 — 90, 559 — 618)

(1HZ Engine)

Output shaft rpm	Vehicle speed (Reference) km/h (mph)		Governor pressure kg/cm ² (psi, kPa)
	Tire size		
	215/80R-16	265/75R-15	
1,000	33 (20)	34 (21)	0.8 – 1.2 (11 – 17, 78 – 118)
1,800	59 (36)	61 (38)	2.0 – 2.4 (28 – 34, 196 – 235)
3,500	114 (71)	118 (74)	5.7 – 6.3 (81 – 90, 559 – 618)

(1HD-T Engine)

Output shaft rpm	Vehicle speed (Reference) km/h (mph)		Governor pressure kg/cm ² (psi, kPa)
	Tire size		
	215/80R-16	265/75R-15	
1,000	33 (20)	34 (21)	1.0 – 1.4 (14 – 20, 98 – 137)
1,800	59 (36)	61 (38)	2.3 – 2.9 (33 – 41, 226 – 284)
3,500	114 (71)	118 (74)	5.7 – 6.3 (81 – 90, 559 – 618)

[Middle East]

Output shaft rpm	Vehicle speed (Reference) km/h (mph)		Governor pressure kg/cm ² (psi, kPa)
	Tire size		
	7.50-16-6	9.00-15-6	
1,000	35 (22)	37 (23)	0.8 – 1.2 (11 – 17, 78 – 118)
1,800	63 (39)	67 (42)	2.0 – 2.4 (28 – 34, 196 – 235)
3,500	123 (76)	130 (81)	5.7 – 6.3 (81 – 90, 559 – 618)
Output shaft rpm	Vehicle speed (Reference) km/h (mph)		Governor pressure kg/cm ² (psi, kPa)
	Tire size		
	31 × 10.5R-15	7.50R16-8	
1,000	34 (21)	35 (22)	0.8 – 1.2 (11 – 17, 78 – 118)
1,800	62 (38)	64 (40)	2.0 – 2.4 (28 – 34, 196 – 235)
3,500	120 (75)	124 (77)	5.7 – 6.3 (81 – 90, 559 – 618)

[Others]

(3F-Engine)

Output shaft rpm	Vehicle speed (Reference) km/h (mph)			Governor pressure kg/cm ² (psi, kPa)
	Tire size			
	7.50-16-6	7.50-16-8	9.00-15-6	
1,000	35 (22)	35 (22)	37 (23)	0.8 – 1.2 (11 – 17, 78 – 118)
1,800	63 (39)	63 (39)	67 (42)	2.0 – 2.4 (28 – 34, 196 – 235)
3,500	123 (76)	123 (76)	130 (81)	5.7 – 6.3 (81 – 90, 559 – 618)
Output shaft rpm	Vehicle speed (Reference) km/h (mph)			Governor pressure kg/cm ² (psi, kPa)
	Tire size			
	31 × 10.5R-15	235/75R-15	7.50R16-8	
	1,000	34 (21)	32 (20)	
1,800	62 (38)	58 (36)	64 (40)	2.0 – 2.4 (28 – 34, 196 – 235)
3,500	120 (75)	112 (70)	124 (77)	5.7 – 6.3 (81 – 90, 559 – 618)

(1HZ Engine)

Output shaft rpm	Vehicle speed (Reference) km/h (mph)			Governor pressure kg/cm ² (psi, kPa)
	Tire size			
	7.50-16-6	7.50-16-8	7.50R16-8	
1,000	35 (22)	35 (22)	35 (22)	0.8 – 1.2 (11 – 17, 78 – 118)
1,800	63 (39)	63 (39)	64 (40)	2.0 – 2.4 (28 – 34, 196 – 235)
3,500	123 (76)	123 (76)	124 (77)	5.7 – 6.3 (81 – 90, 559 – 618)
	9.00-15-6	31 × 10.5R-6	—	Governor pressure kg/cm ² (psi, kPa)
1,000	37 (23)	34 (21)	—	0.8 – 1.2 (11 – 17, 78 – 118)
1,800	67 (42)	62 (38)	—	2.0 – 2.4 (28 – 34, 196 – 235)
3,500	130 (81)	120 (75)	—	5.7 – 6.3 (81 – 90, 559 – 618)

(1HD-T Engine)

Output shaft rpm	Vehicle speed (Reference) km/h (mph)			Governor pressure kg/cm ² (psi, kPa)
	Tire size			
	7.50-16-6	7.50-16-8	7.50R16-8	
1,000	35 (22)	35 (22)	35 (22)	1.0 – 1.4 (14 – 20, 98 – 137)
1,800	63 (39)	63 (39)	64 (40)	2.3 – 2.9 (33 – 41, 226 – 284)
3,500	123 (76)	123 (76)	124 (77)	5.7 – 6.3 (81 – 90, 559 – 618)
	9.00-15-6	31 × 10.5R-6	—	Governor pressure kg/cm ² (psi, kPa)
1,000	37 (23)	34 (21)	—	1.0 – 1.4 (14 – 20, 98 – 137)
1,800	67 (42)	62 (38)	—	2.3 – 2.9 (33 – 41, 226 – 284)
3,500	130 (81)	120 (75)	—	5.7 – 6.3 (81 – 90, 559 – 618)

EVALUATION

If governor pressure is defective:

- Line pressure defective
- Fluid leakage in governor pressure circuit
- Governor valve operation defective

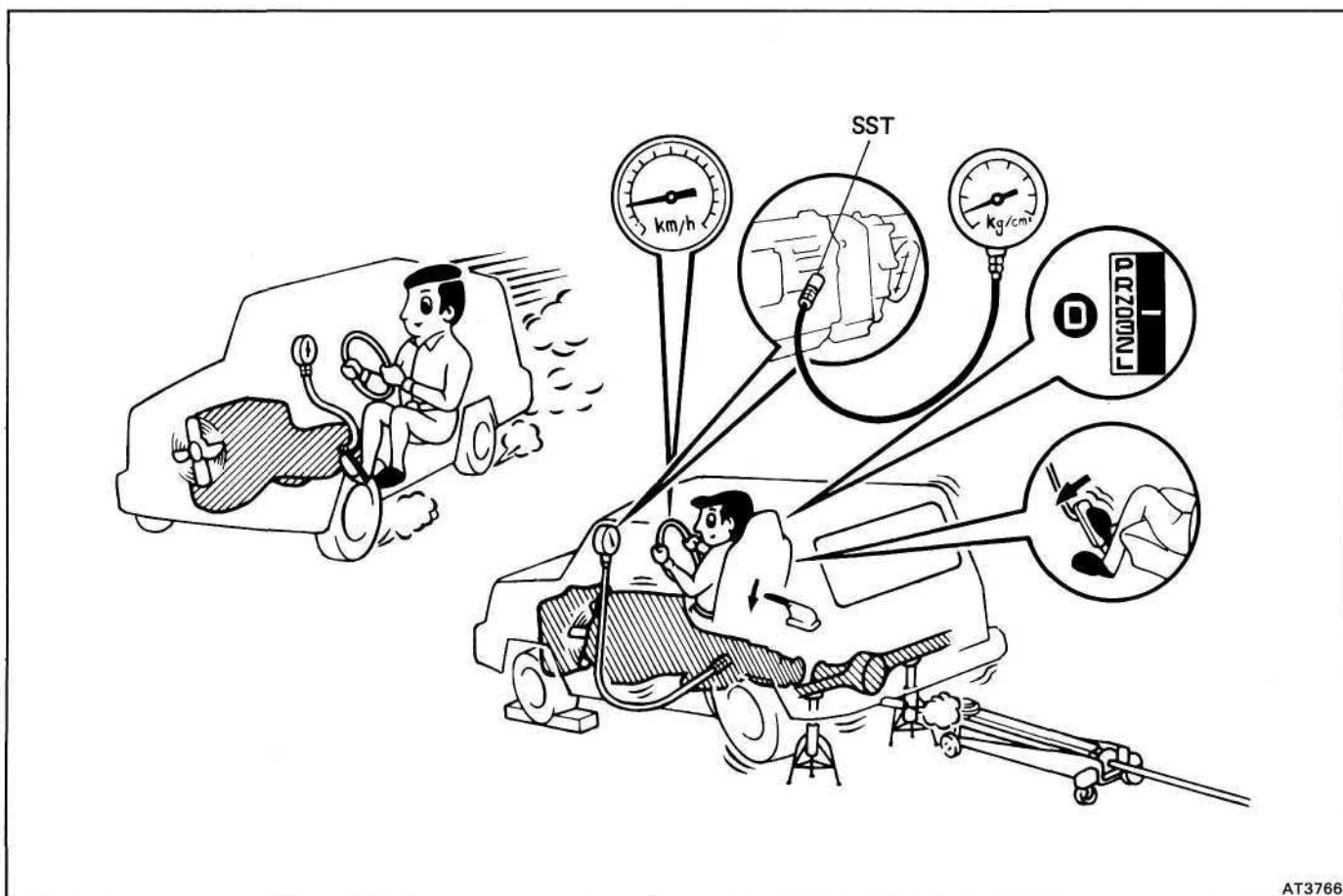

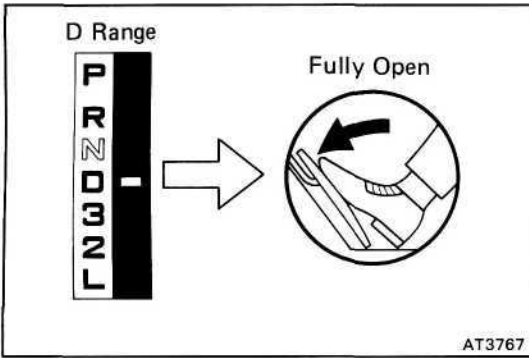

ROAD TEST

NOTICE: Perform the test at normal operating fluid temperature (50 - 80 °C or 122 - 176 °F)

1. D RANGE TEST

Shift into the D range and while driving with the accelerator pedal held constant at full throttle valve opening position, check the following points:

- Check to see that the 1 → 2, 2 → 3 and 3 → O/D up-shifts take place, and shift points should conform to those shown in the automatic shift schedule.

EVALUATION

- If there is no 1 → 2 up-shift:
 - Governor valve is defective
 - 1-2 shift valve is stuck
- If there is no 2 → 3 up-shift:
 - Governor valve is defective
 - 2-3 shift valve is stuck
- If there is no 3 → O/D up-shift:
 - Governor valve is defective
 - 3-4 shift valve is stuck
- If the shift point is defective:
 - Throttle cable is out-of-adjustment
 - Throttle valve, 1-2 shift valve, 2-3 shift valve, 3-4 shift valve etc., are defective

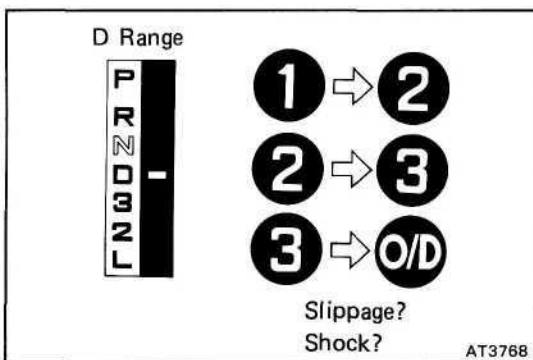

- In the same manner, check the shock and slip at the 1 → 2, 2 → 3 and 3 → O/D up-shifts.

EVALUATION

If the shock is excessive:

- Line pressure is too high
- Accumulator is defective
- Check ball is defective

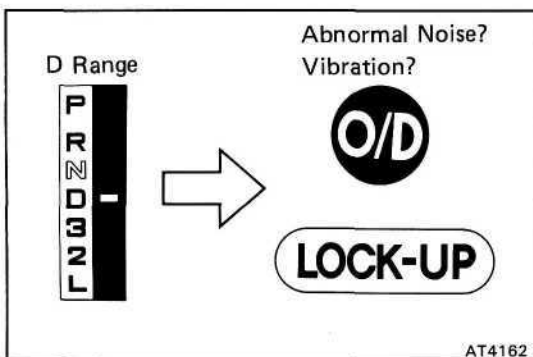

- Run in the O/D gear or lock-up of the D range and check for abnormal noise and vibration.

HINT: The check for the cause of abnormal noise and vibration must be made with extreme care as it could also be due to loss of balance in the propeller shafts, differentials, torque converter, etc.

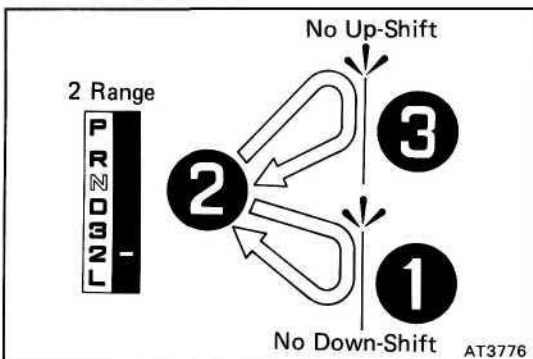
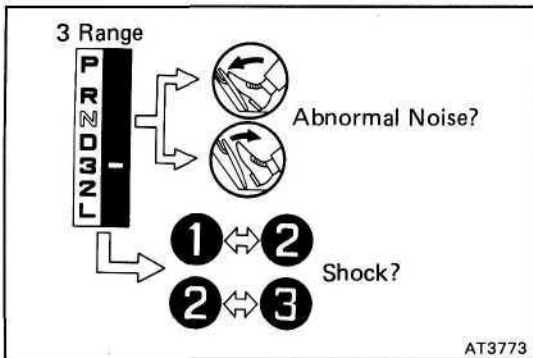
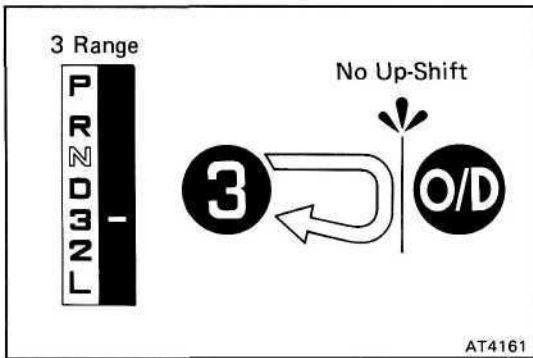
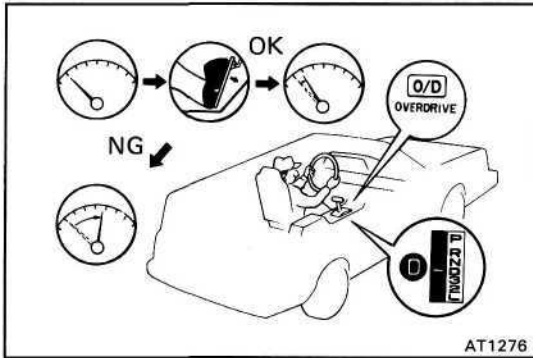
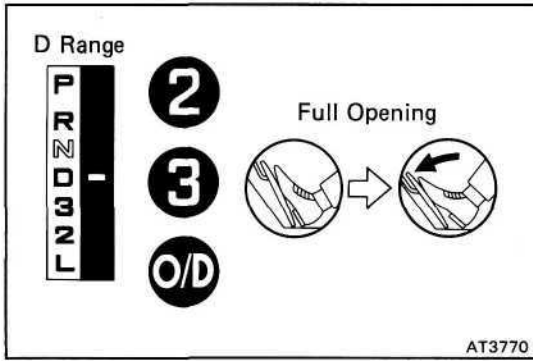

(d) While running in the 2nd, 3rd, or O/D gear of the D range, check to see that the possible kick-down vehicle speed limits for 2 → 1, 3 → 2 or O/D → 3 kick-downs conform to those indicated on the automatic shift schedule.

(e) Check for abnormal shock and slip at kick-down.

(f) Check for the lock-up mechanism.

(1) Drive in O/D gear of the D range, at a steady speed (lock-up ON) of about 85 km/h (53 mph).

(2) Lightly depress the accelerator pedal and check that the engine rpm does not change abruptly.

If there is a big jump in engine rpm, there is no lock-up.

2. 3 RANGE TEST

(a) While running in the 3rd gear of the 3 range, check to see that there is no up-shift to the O/D gear.

(b) Check for abnormal noise at acceleration and deceleration, and for shock at up-shift and down-shift.

3. 2 RANGE TEST

(a) While running in the 2nd gear of the 2 range, check to see that there is no up-shift to the 3rd gear.

(b) While running in the 2nd gear of the 2 range, check to see that there is no down-shift to the 1st gear.

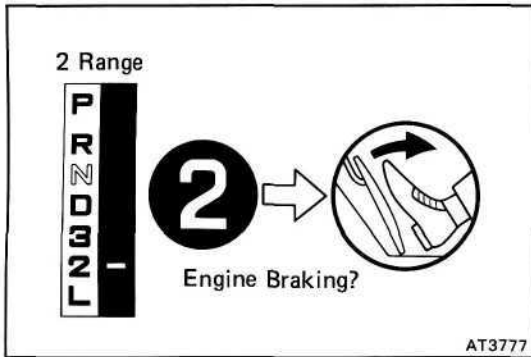

- (c) While running in the 2nd gear of the 2 range, release the accelerator pedal and check the engine braking effect.

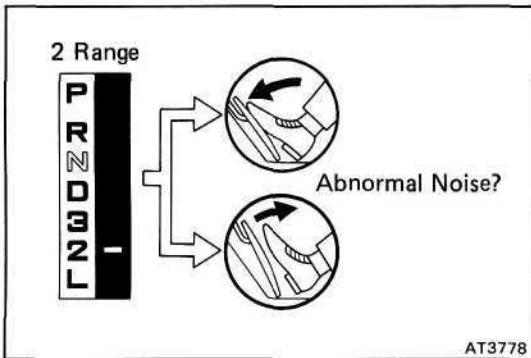

- (d) Check for abnormal noise during acceleration and deceleration.

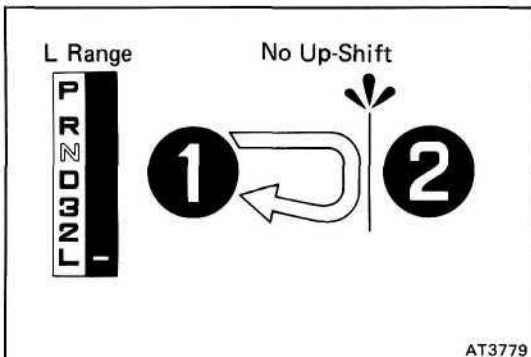

4. L RANGE TEST

- (a) While running in the L range, check to see that there is no up-shift to the 2nd gear.

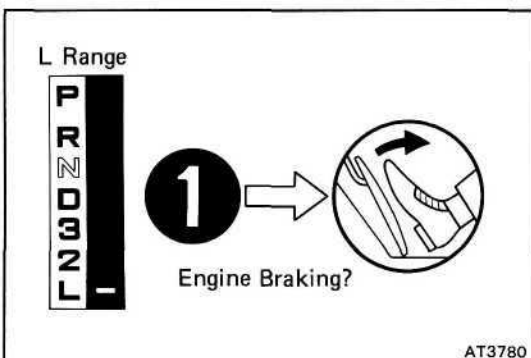

- (b) While running in the L range, release the accelerator pedal and check the engine braking effect.

EVALUATION

If there is no engine braking effect:

- First and reverse brake is defective

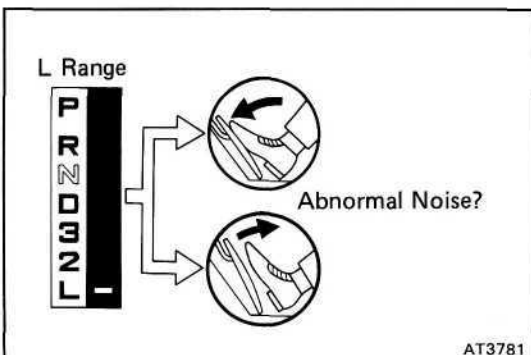

- (c) Check for abnormal noise during acceleration and deceleration.

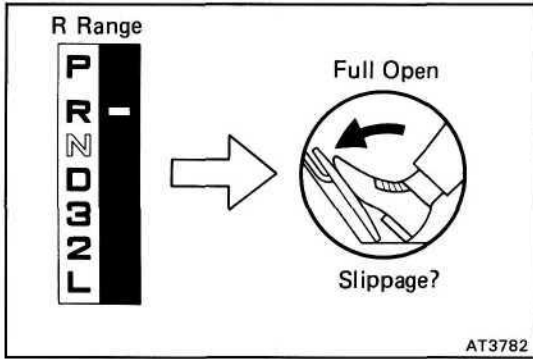

5. R RANGE TEST

Shift into the R range and, while starting at full throttle, check for slipping.

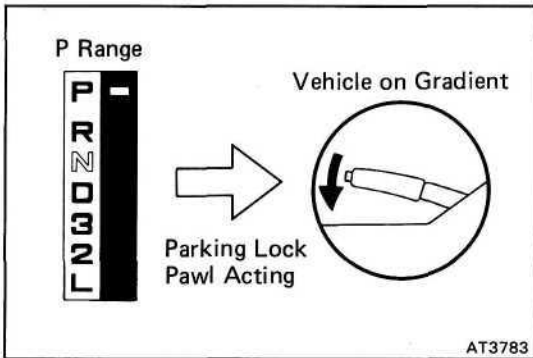

6. P RANGE TEST

Stop the vehicle on a gradient (more than 9 %) and after shifting into the P range, release the parking brake. Then check to see that the parking lock pawl holds the vehicle in place.

Automatic Shift Schedule

(Australia)

km/h (mph)

		Throttle valve fully open						(fully closed)		2 range	1 range
Engine	Tire Size	1→2	2→3	3→O/D	OD→3	3→2	2→1	*1	*2	3→2	2→1
3F-E	7.50R-16-6	37-52 (23-32)	83-98 (52-61)	122-137 (76-85)	112-128 (70-80)	72-87 (45-54)	31-46 (19-29)	80-92 (50-57)	76-87 (47-54)	85-101 (53-63)	39-54 (24-34)
	265/75R-15	35-50 (22-31)	80-95 (50-59)	117-132 (73-82)	108-123 (67-76)	70-84 (43-52)	30-44 (19-27)	77-88 (48-55)	73-84 (48-52)	82-97 (51-60)	37-52 (23-32)
1HD-T	7.50R-16-6	27-42 (17-26)	73-88 (45-55)	124-139 (77-86)	114-129 (71-80)	60-75 (37-47)	19-35 (12-22)	73-85 (45-53)	69-80 (43-50)	78-93 (48-58)	35-49 (22-30)
	265/75R-15	25-40 (16-25)	69-84 (43-52)	117-132 (73-82)	108-123 (67-76)	57-72 (35-45)	18-33 (11-21)	69-81 (43-50)	65-76 (40-47)	74-88 (46-55)	33-46 (21-29)

*1 Lock-up ON *2 Lock-up OFF

(Europe)

km/h(mph)

		Throttle valve fully open						(fully closed)		2 range	1 range
Engine	Tire Size	1→2	2→3	3→O/D	OD→3	3→2	2→1	*1	*2	3→2	2→1
3F-E	265/75R-15	35-50 (22-31)	80-95 (50-59)	117-132 (73-82)	108-123 (67-76)	70-84 (43-52)	30-44 (19-27)	77-88 (48-55)	73-84 (45-52)	82-97 (51-60)	37-52 (23-32)
	215/80R-16	33-47 (21-29)	76-90 (47-56)	111-125 (69-78)	103-117 (64-73)	66-80 (41-50)	28-42 (17-26)	73-84 (45-52)	69-80 (43-50)	78-92 (48-57)	36-50 (22-31)
1HZ	265/75R-15	30-45 (19-28)	74-89 (46-55)	117-132 (73-82)	108-123 (67-76)	64-79 (40-49)	25-39 (16-24)	72-83 (45-52)	67-79 (42-49)	76-91 (47-57)	36-51 (22-32)
	215/80R-16	29-43 (18-27)	70-84 (43-52)	111-125 (69-78)	103-116 (64-72)	61-75 (38-47)	24-38 (15-24)	68-79 (42-49)	64-75 (40-47)	73-87 (45-54)	34-48 (21-30)
1HD-T	265/75R-15	25-40 (16-25)	69-84 (43-52)	117-132 (73-82)	108-123 (67-76)	57-72 (35-45)	18-33 (11-21)	69-81 (43-50)	65-76 (40-47)	74-88 (46-55)	33-46 (21-29)
	215/80R-16	24-38 (15-24)	66-80 (41-50)	111-125 (69-78)	103-117 (64-73)	54-68 (34-42)	17-31 (11-19)	66-77 (41-48)	62-73 (39-45)	70-84 (43-52)	32-44 (30-27)

*1 Lock-up ON *2 Lock-up OFF

(Middle East)

km/h (mph)

		Throttle valve fully open						(fully closed)		2 range	1 range
Engine	Tire Size	1→2	2→3	3→O/D	OD→3	3→2	2→1	*1	*2	3→2	2→1
3F	7.50-16-6	31-47 (19-29)	77-92 (48-57)	121-137 (75-85)	112-127 (70-79)	67-82 (42-51)	26-41 (16-25)	74-86 (46-53)	70-81 (43-50)	79-94 (49-58)	45-58 (28-36)
	9.00-15-6	33-49 (21-30)	81-97 (50-60)	128-143 (80-89)	118-133 (73-83)	70-86 (43-53)	27-43 (17-27)	78-90 (48-56)	73-86 (45-53)	83-99 (52-62)	45-61 (28-38)
	31 × 10.5R-15	30-45 (19-28)	75-89 (47-55)	118-133 (73-83)	109-123 (68-76)	65-80 (40-50)	25-40 (16-25)	72-83 (45-52)	68-79 (42-49)	77-92 (48-57)	41-56 (25-35)
	7.50R-16-8	32-47 (20-29)	78-94 (48-58)	124-139 (77-86)	114-129 (71-80)	68-83 (42-52)	27-42 (17-26)	75-87 (47-54)	71-83 (44-52)	81-96 (50-60)	43-59 (27-37)

* 1 Lock-up ON * 2 Lock-up OFF

(Others)

km/h (mph)

		Throttle valve fully open						(fully closed)		2 range	1 range
Engine	Tire Size	1→2	2→3	3→O/D	OD→3	3→2	2→1	*1	*2	3→2	2→1
3F	7.50-16-6	31-47 (19-29)	77-92 (48-57)	121-137 (75-85)	112-127 (70-79)	67-82 (42-51)	26-41 (16-25)	74-86 (46-53)	70-81 (43-50)	79-94 (49-58)	43-58 (28-36)
	7.50-16-8										
	9.00-15-6	33-49 (21-30)	81-97 (50-60)	128-143 (80-89)	118-133 (73-83)	70-86 (43-53)	27-43 (17-27)	78-90 (48-56)	73-86 (45-53)	83-99 (52-62)	45-61 (28-38)
	31 × 10.5R-15	30-45 (19-28)	75-89 (47-55)	118-133 (73-83)	109-123 (68-76)	65-80 (40-50)	25-40 (16-25)	72-83 (45-52)	68-79 (42-49)	77-92 (48-57)	41-56 (25-35)
	7.50R-16-8	32-47 (20-29)	78-94 (48-58)	124-139 (77-86)	114-129 (71-80)	68-83 (42-52)	27-42 (17-26)	75-87 (47-54)	71-83 (44-52)	81-96 (50-60)	43-59 (27-37)
	235/75R-15	28-42 (17-26)	69-83 (43-52)	110-123 (68-76)	101-115 (63-71)	60-74 (37-46)	23-37 (14-23)	67-78 (42-48)	63-74 (39-46)	71-85 (44-53)	39-52 (24-32)
1HZ	7.50-16-6	31-47 (19-29)	77-92 (48-57)	121-137 (75-85)	112-127 (70-79)	67-82 (42-51)	26-41 (16-25)	74-86 (46-53)	70-81 (43-50)	79-94 (49-58)	43-58 (28-36)
	7.50-16-8										
	7.50R-16-8	32-47 (20-29)	78-94 (48-58)	124-139 (77-86)	114-129 (71-80)	68-83 (42-52)	27-42 (17-26)	75-87 (47-54)	71-83 (44-52)	81-96 (50-60)	38-53 (24-33)
	9.00-15-6	33-49 (21-30)	81-97 (50-60)	128-143 (80-89)	118-133 (73-83)	70-86 (43-53)	28-43 (17-27)	78-90 (48-56)	73-86 (45-53)	83-99 (52-62)	39-55 (24-34)
	31 × 10.5R-15	30-45 (19-28)	75-89 (47-55)	118-133 (73-83)	109-123 (68-76)	65-80 (40-50)	25-40 (16-25)	72-83 (45-52)	68-79 (42-49)	77-92 (48-57)	36-51 (22-32)
1HD-T	7.50-16-6	26-41 (16-25)	72-87 (45-54)	121-137 (75-85)	112-127 (70-79)	59-74 (37-46)	19-34 (12-21)	72-83 (45-52)	67-79 (42-49)	76-92 (47-57)	35-48 (22-30)

* 1 Lock-up ON * 2 Lock-up OFF

km/h (mph)

Engine	Tire Size	Throttle valve fully open						(fully closed)		2 range	1 range
		1→2	2→3	3→O/D	OD→3	3→2	2→1	*1	*2	3→2	2→1
1HD-T	7.50-16-8	26-41 (16-25)	72-87 (45-54)	121-137 (75-85)	112-127 (70-79)	59-74 (37-46)	19-34 (12-21)	72-83 (45-52)	67-79 (42-49)	76-92 (47-57)	35-48 (22-30)
	7.50R-16-8	27-42 (17-26)	73-88 (45-55)	124-139 (77-86)	114-129 (71-80)	60-75 (37-47)	19-35 (12-22)	73-85 (45-53)	69-80 (43-50)	78-93 (48-58)	35-49 (22-30)
	9.00-15-6	27-43 (17-27)	75-91 (47-57)	128-143 (80-89)	118-133 (73-83)	62-78 (39-48)	20-36 (12-22)	76-88 (47-55)	71-83 (44-52)	62-78 (39-48)	20-36 (12-22)
	31 × 10.5R-15	25-40 (16-25)	70-84 (43-52)	118-133 (73-83)	109-123 (68-76)	57-72 (35-45)	18-33 (11-21)	70-81 (43-50)	65-77 (40-48)	74-89 (46-55)	34-47 (21-29)

* 1 Lock-up ON * 2 Lock-up OFF

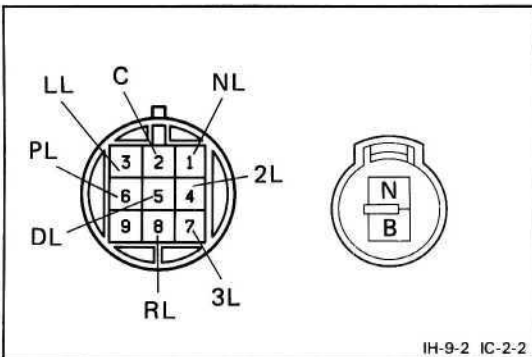

Neutral Start Switch

INSPECT NEUTRAL START SWITCH

Using an ohmmeter, check the continuity of the terminals for each switch position shown in the table below.

Terminal Switch position	B	N	C	PL	RL	NL	DL	3L	2L	LL
P range	○—○		○—○							
R range			○—○	○—○						
N range	○—○		○—○	○—○	○—○					
D range			○—○	○—○	○—○	○—○				
3 range			○—○	○—○	○—○	○—○	○—○			
2 range			○—○	○—○	○—○	○—○	○—○	○—○		
L range			○—○	○—○	○—○	○—○	○—○	○—○	○—○	

If continuity between terminals is not as specified, replace the switch.

O/D Solenoid (w/ Cruise Control System)

CHECK SOLENOID SEAL

If there is foreign material in the solenoid valve, there will be no fluid control even with solenoid operation.

- Applying compressed air, check that the solenoid valve opens.
- When supply battery voltage to the solenoid, check that the solenoid valve does not leak the air.

If operation is not as specified, replace the solenoid.

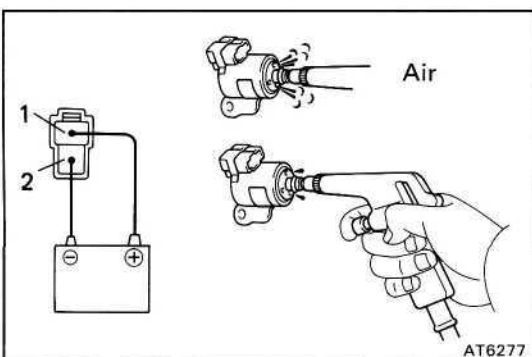

A/T Fluid Temperature Warning System

A/T FLUID TEMPERATURE WARNING SYSTEM CIRCUIT

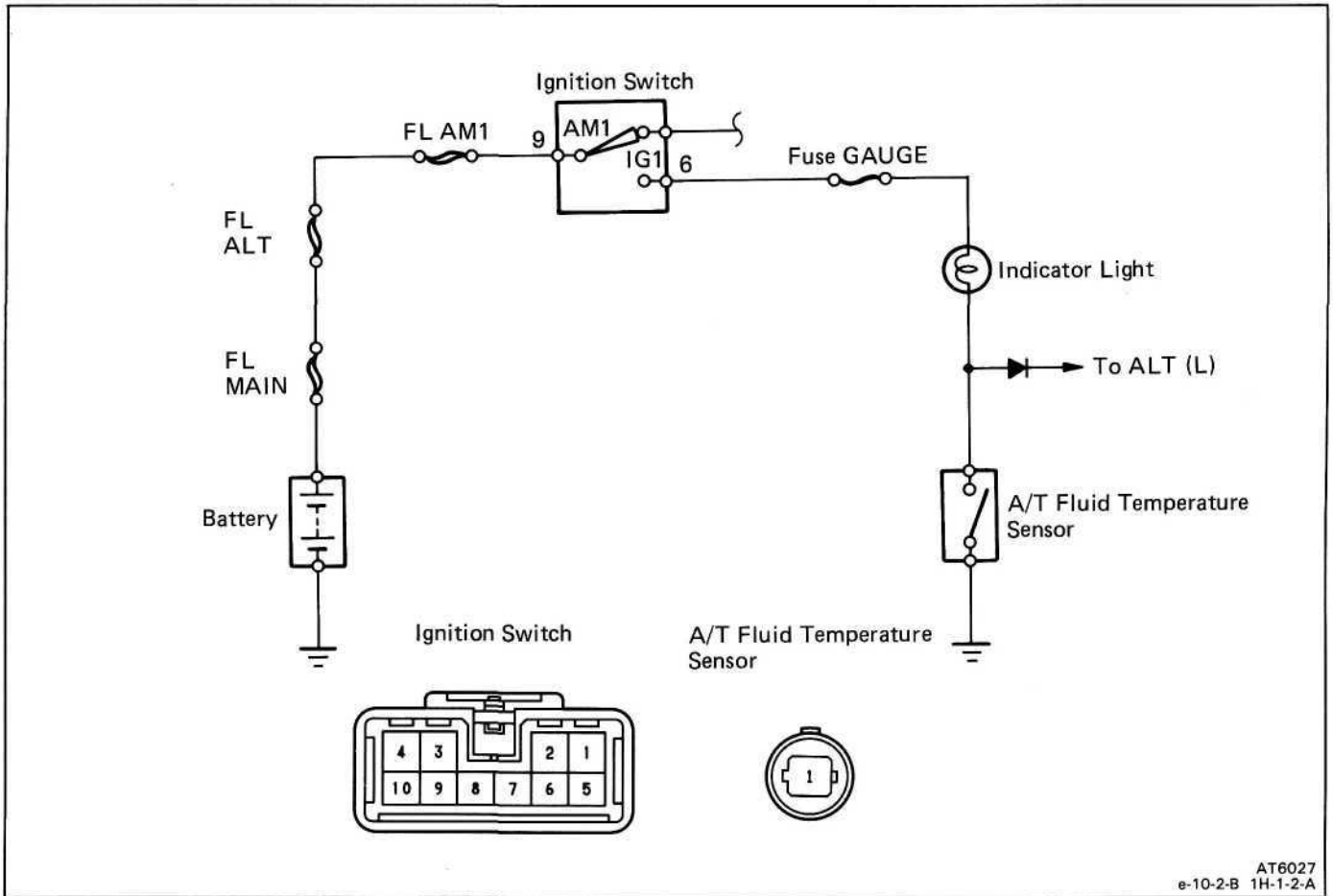

AT6027
e-10-2-B 1H-1-2-A

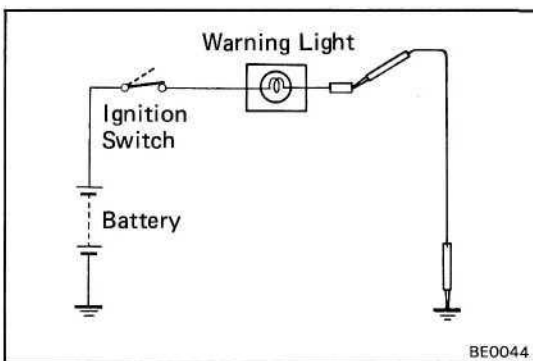

BE0044

INSPECTION OF A/T FLUID TEMPERATURE WARNING SYSTEM COMPONENTS

1. INSPECT A/T FLUID TEMPERATURE WARNING LIGHT

- (a) Disconnect the connector from the temperature switch. Connect terminal of the wire harness side connector and body ground.
- (b) Turn the ignition switch ON, check that the light go on.

If warning light does not light, test the bulb.

2. INSPECT A/T FLUID TEMPERATURE SENSOR

Check that there is continuity at the temperature of 145°C - 155°C (325°F - 343°F).

If continuity is not as specified, replace the sensor.

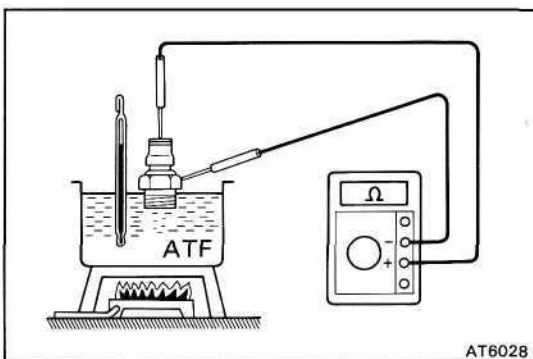

AT6028

ON-VEHICLE REPAIR

Valve Body

REMOVAL OF VALVE BODY

1. MAKE PLATE TO RETAIN ACCUMULATOR PISTONS

A retainer is helpful for holding accumulator pistons in the case during removal and installation of the valve body.

The plate may be made from aluminum or plastic.

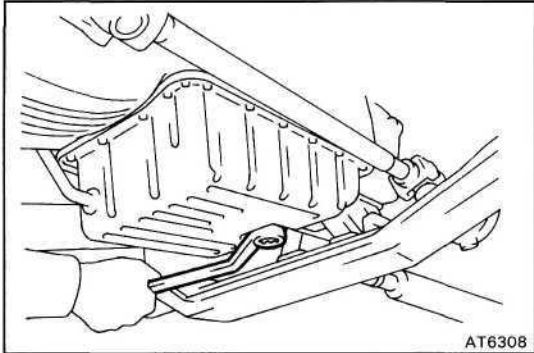

2. REMOVE TRANSMISSION AND TRANSFER UNDER COVERS

3. CLEAN TRANSMISSION EXTERIOR

To help prevent contamination, clean the exterior of the transmission.

4. DRAIN TRANSMISSION FLUID

Remove the drain plug and drain fluid into a suitable container.

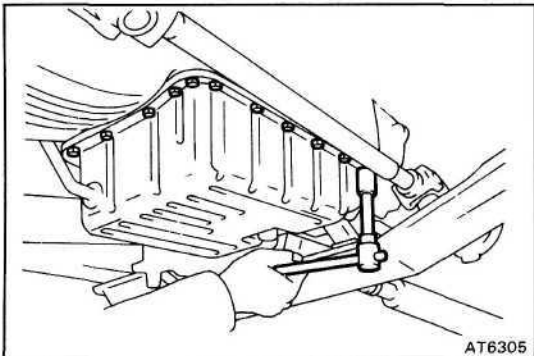

5. REMOVE OIL PAN AND GASKET

NOTICE: Some fluid will remain in the oil pan. Be careful not to damage the filler tube.

Insert the blade of SST between the transmission and oil pan, cut off applied sealer.

SST 09032-00010

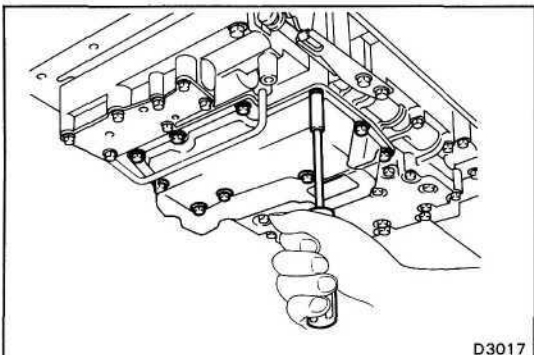

6. REMOVE OIL STRAINER AND GASKET

(a) Remove the ten bolts and oil strainer.

NOTICE: Be careful as some oil will come out with the filter.

(b) Remove the gasket.

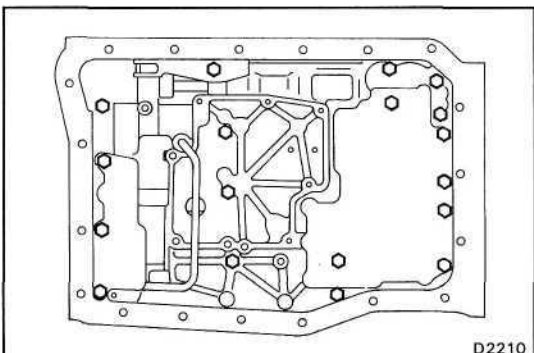

7. REMOVE VALVE BODY

(a) Remove the eighteen bolts.

HINT: Support the valve body by hand to prevent it from falling.

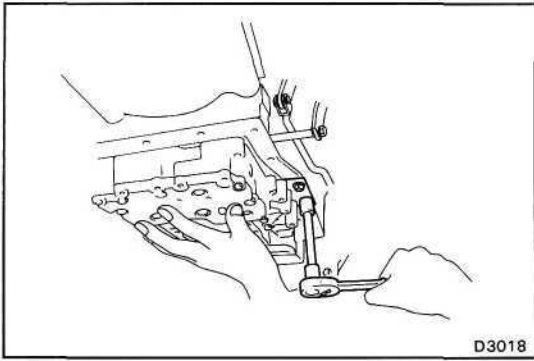

- (b) Lower valve body slightly, and install the accumulator piston retaining plate. Hold in place with two pan bolts, and hand tighten.

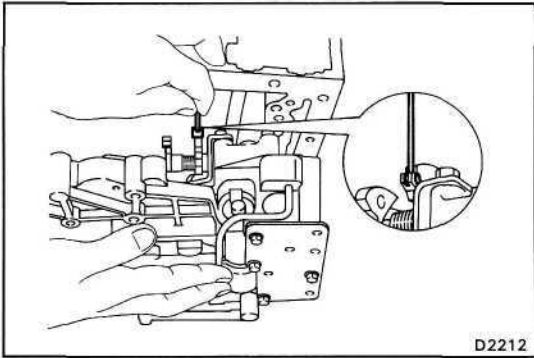

- (c) Disconnect the throttle cable from the cam and remove the valve body.

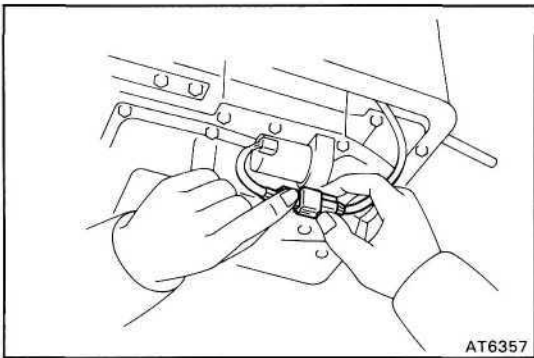

- (d) (w/ Cruise Control System: 3F-E engine Australia) Disconnect the solenoid wiring, throttle cable and remove the valve body.

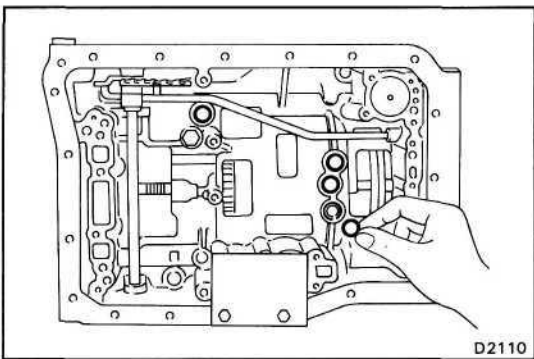

8. REMOVE FOUR CENTER SUPPORT APPLY GASKETS

INSTALLATION OF VALVE BODY

1. INSTALL FOUR CENTER SUPPORT APPLY GASKETS

Install the four center support apply gaskets, facing the pitted sides toward the transmission case.

2. CONNECT THROTTLE CABLE TO CAM

Push the cable fitting into the cam.

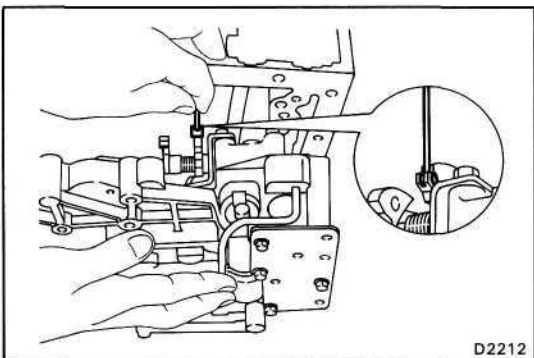

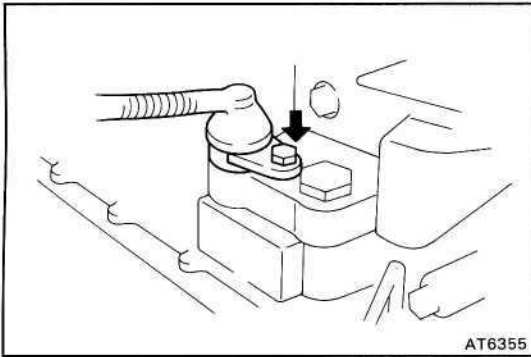
**(w/ Cruise Control System)**

Push the cable fitting into the cam and connect the solenoid wiring connector.

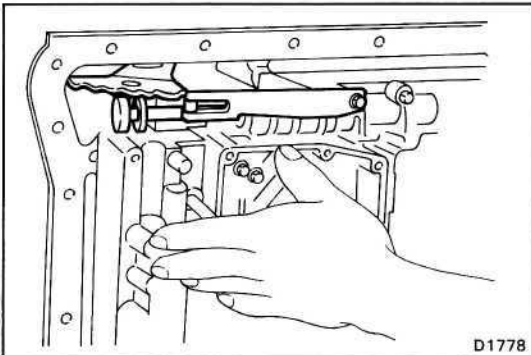
**3. INSTALL VALVE BODY**

(a) Align the manual valve lever with the manual valve.

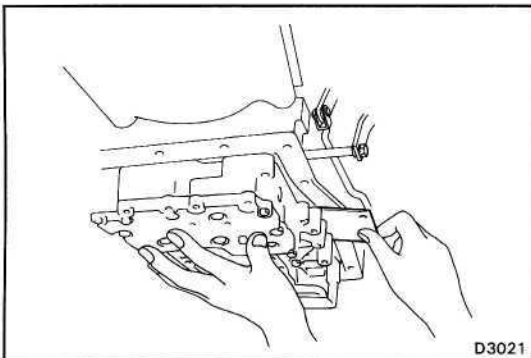

(b) Remove the two pan bolts, and slide out the accumulator retaining plate.

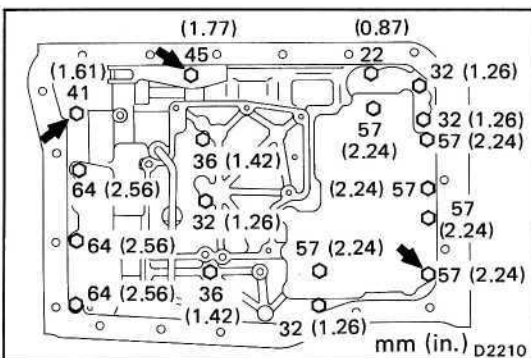
**4. INSTALL VALVE BODY BOLTS**

(a) Install the three bolts indicated by the arrows.

(b) Install the other bolts.

(c) Check that the manual valve lever contacts the center of the roller at the tip of the detent spring.

(d) Tighten the bolts.

Torque: 100 kg-cm (7 ft-lb, 10 Nm)

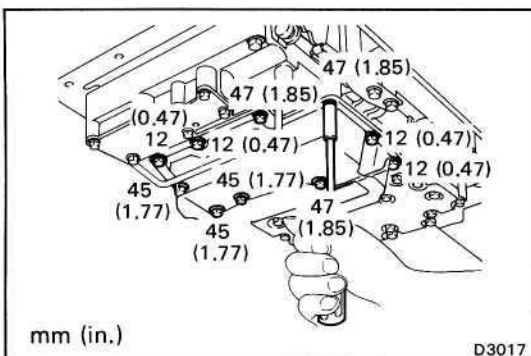
**5. INSTALL OIL STRAINER**

Be sure the strainer is clean. Install a new gasket and strainer.

Torque: 5 mm bolt 55 kg-cm (48 in.-lb, 5.4 Nm)
6 mm bolt 100 kg-cm (7 ft-lb, 10 Nm)

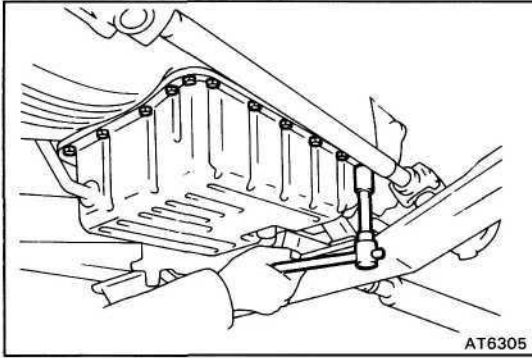

6. INSTALL PAN WITH NEW GASKET

- (a) Remove any packing material and be careful not to drop oil on the contacting surface of the transmission case and oil pan.
- (b) Apply seal packing to the oil pan.

Seal packing: Part No. 08826-00090, THREE BOND 1281B or equivalent

- (c) Install and torque the twenty bolts.
Torque: 70 kg-cm (61-in.-lb, 6.9 Nm)

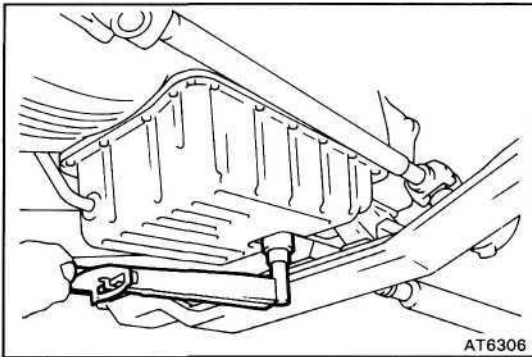

7. INSTALL DRAIN PLUG

- (a) Install a new gasket and drain plug.
- (b) Torque the drain plug.

Torque: 280 kg-cm (20 ft-lb, 27 Nm)

8. INSTALL TRANSMISSION UNDER COVER AND TRANSFER UNDER COVER

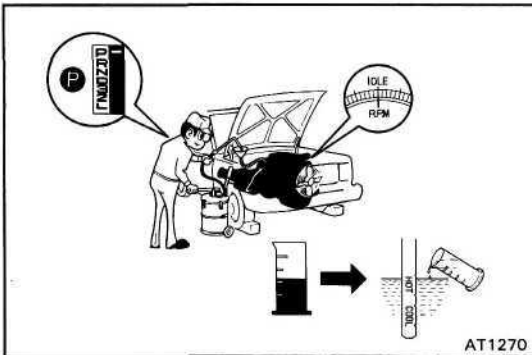

9. FILL TRANSMISSION WITH ATF

Add 6.0 liters (6.3 US qts, 5.3 Imp. qts)

NOTICE: Do not overfill.

Fluid type: ATF DEXRON® n

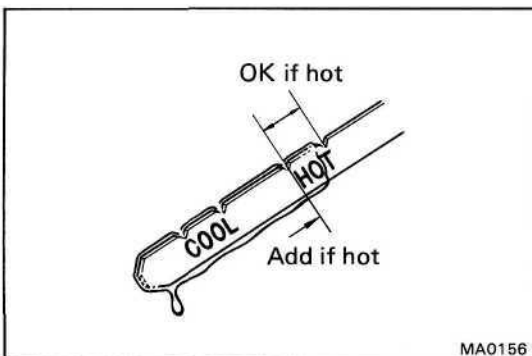

10. CHECK FLUID LEVEL (See page AT-12)

Throttle Cable

REMOVAL OF THROTTLE CABLE

- 1. REMOVE FRONT PROPELLER SHAFT (See page PR-2)**
- 2. DISCONNECT THROTTLE CABLE**
 - (a) Disconnect the cable housing from the bracket.
 - (b) Disconnect the cable from the throttle linkage.
 - (c) Disconnect the cable from the torque converter housing.

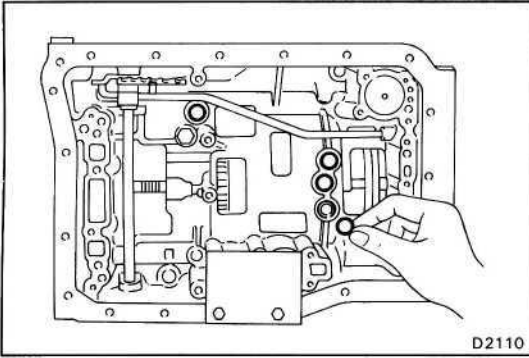

3. REMOVE VALVE BODY (See page AT-29)
4. REMOVE FOUR CENTER SUPPORT APPLY GASKETS

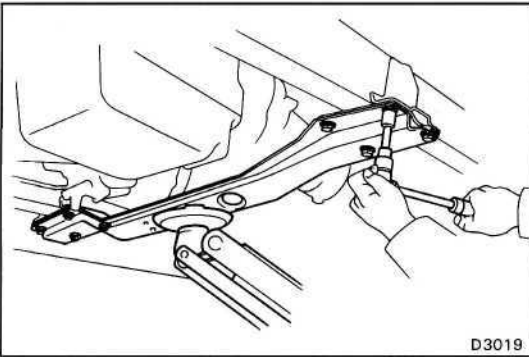

5. REMOVE FRAME CROSSMEMBER SET BOLTS
 - (a) Support the frame crossmember with jack.
 - (b) Remove the eight set bolts.

6. REMOVE THROTTLE CABLE CLAMP

- (a) Lower the jack.
- (b) Remove the cable clamp from the transmission housing.

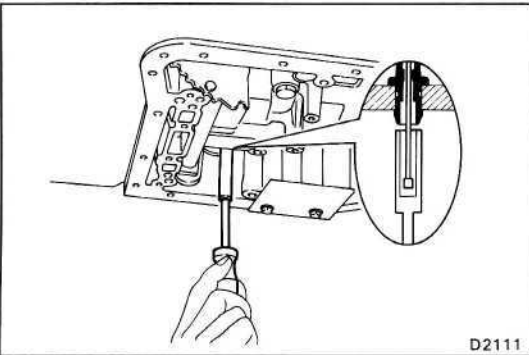

7. PUSH THROTTLE CABLE OUT OF TRANSMISSION CASE
Using 10 mm socket, push the throttle cable out.

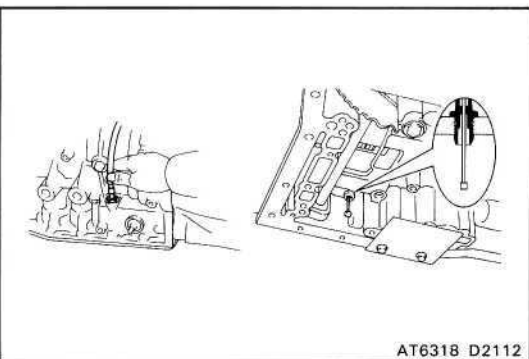

INSTALLATION OF THROTTLE CABLE

1. INSTALL CABLE IN TRANSMISSION CASE

Be sure to push it in all the way.

2. INSTALL THROTTLE CABLE CLAMP TO TRANSMISSION HOUSING

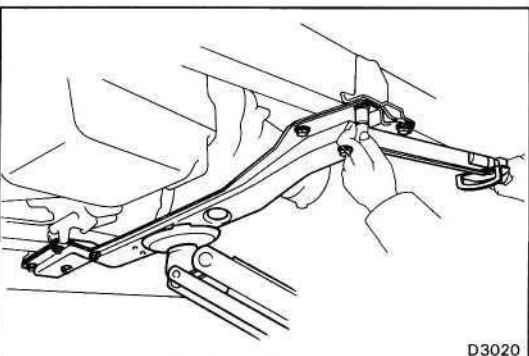

3. INSTALL FRAME CROSSMEMBER SET BOLTS

Torque: 620 kg-cm (45 ft-lb, 61 Nm)

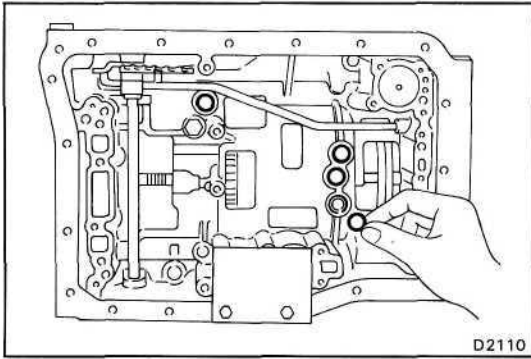

4. INSTALL FOUR CENTER SUPPORT APPLY GASKETS
5. INSTALL VALVE BODY (See page AT-31)
6. INSTALL FRONT PROPELLER SHAFT (See page PR-2)

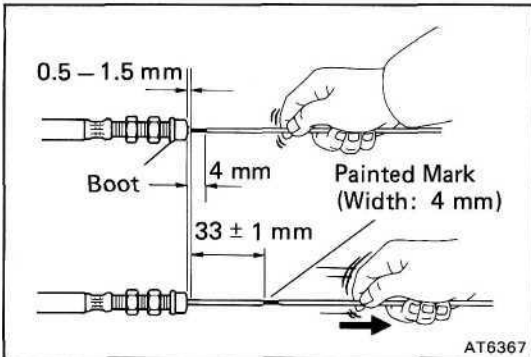

7. IF THROTTLE CABLE IS NEW, PAINT MARK ON INNER CABLE

HINT: New cables do not have a cable stopper installed. Therefore to mark adjustment possible, paint a mark as described below.

- (a) Connect the throttle cable to the throttle cam of valve body.
- (b) Pull the inner cable lightly until resistance is felt, and hold it.
- (c) Paint a mark as shown, about 4 mm (0.16 in.) in width.
- (d) Pull the inner cable fully, measure the cable stroke.

Cable stroke: 33 ± 1 mm (1.30 ± 0.04 in.)

8. CONNECT THROTTLE CABLE

- (a) Connect the cable to the throttle linkage.
- (b) Connect the cable housing to the bracket on the valve cover.

9. ADJUST THROTTLE CABLE (See page AT-13)

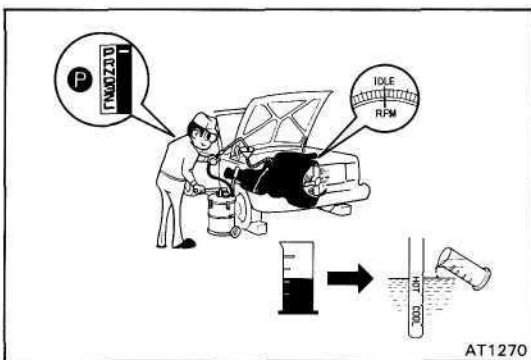

10. FILL TRANSMISSION WITH ATF

Add 6 liters (6.3 US qts, 5.3 Imp. qts)

NOTICE: Do not overfill.

Fluid type: ATF DEXRON® II

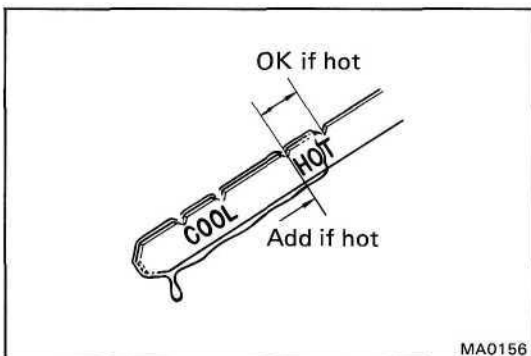

11. CHECK FLUID LEVEL (See page AT-12)

REMOVAL AND INSTALLATION OF TRANSMISSION

Remove and install the parts as shown.

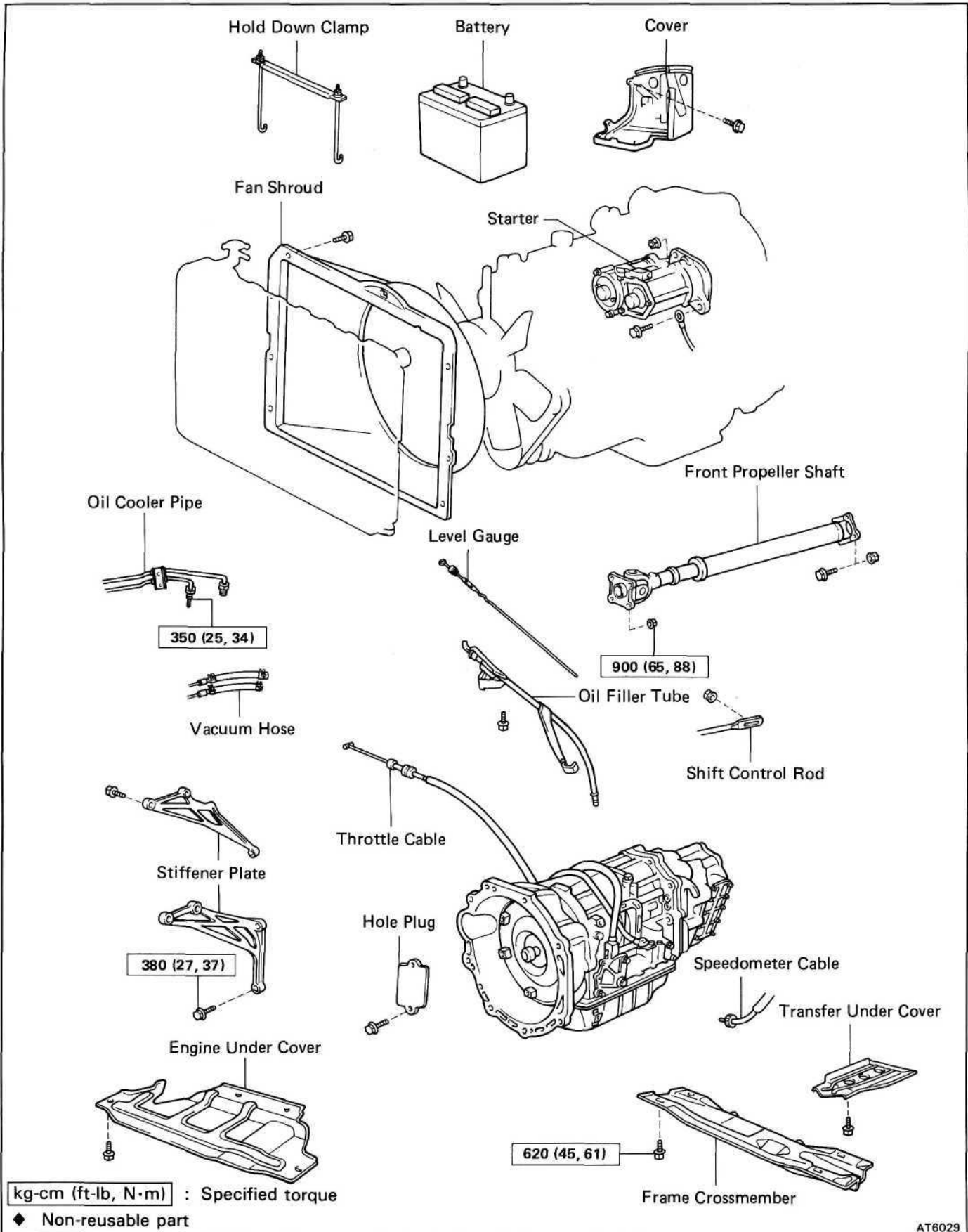

(Cont'd)

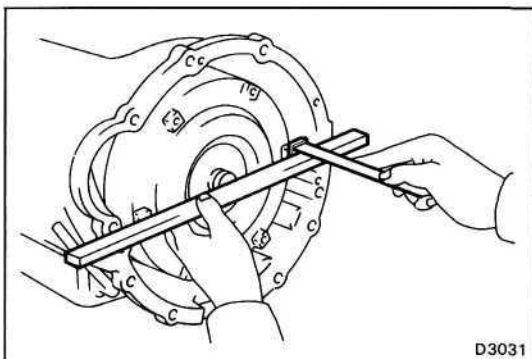
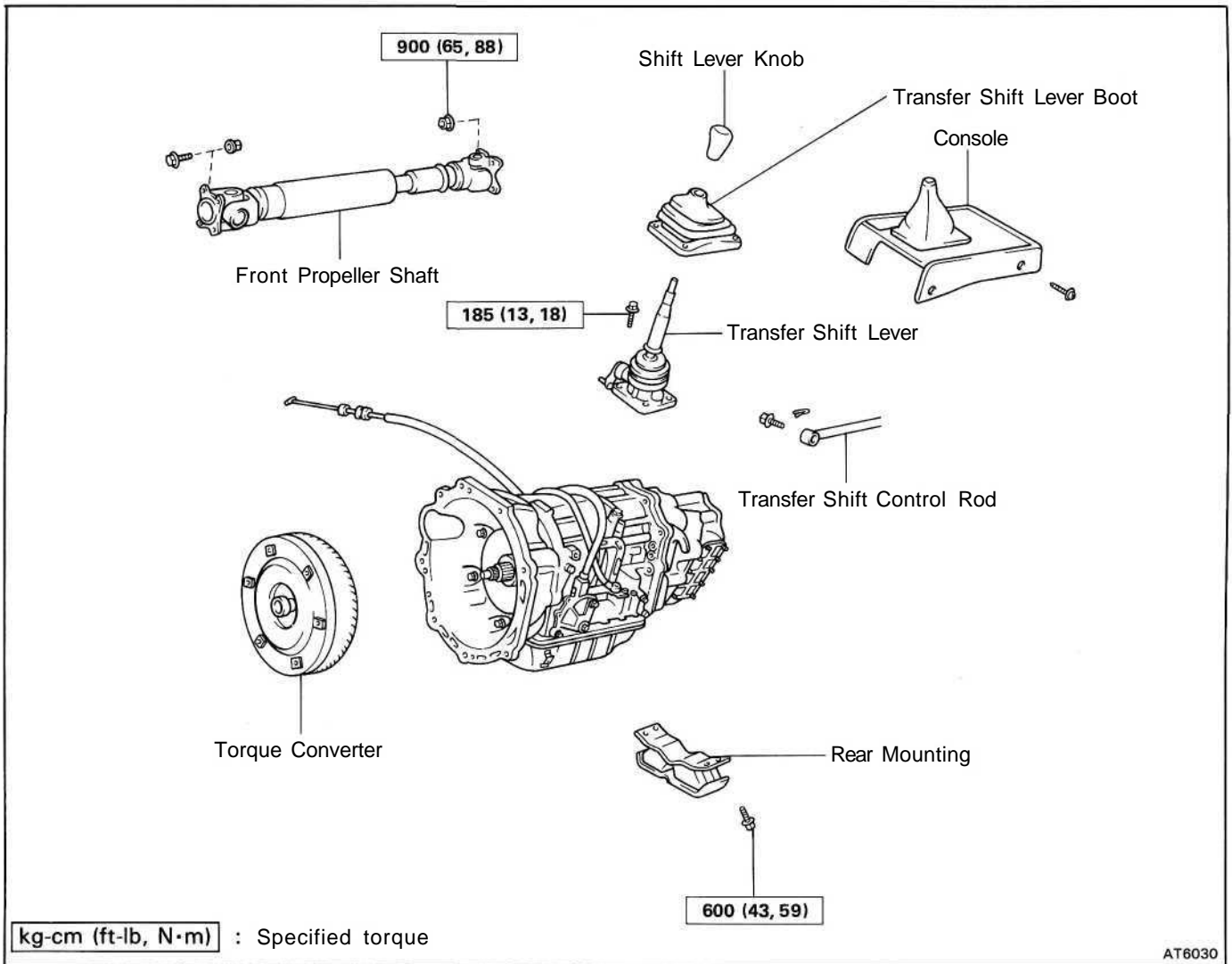

(MAIN POINT OF INSTALLATION)

CHECK TORQUE CONVERTER INSTALLATION

Using calipers and a straight edge, measure from the installed surface of the torque converter to the front surface of the transmission housing.

Correct distance:

- 3F engine 16.5 mm (0.650 in.) or more
- 1H engine 41.2 mm (1.622 in.) or more

NOTICE: Install the converter horizontally to prevent oil seal from damage:

If the distance is less than the standard, check for an improper installation.

REMOVAL OF TRANSMISSION

1. DISCONNECT BATTERY CABLE FROM NEGATIVE TERMINAL
2. REMOVE BATTERY AND COVER

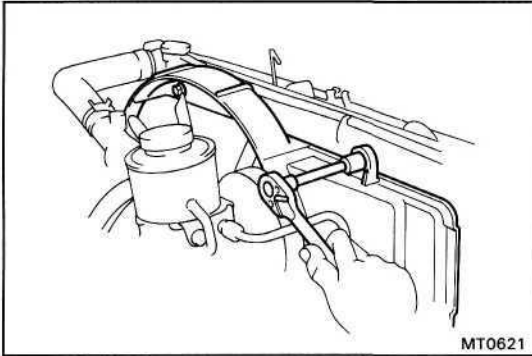

3. LOOSEN THE FAN SHROUD OF THE COOLING FAN TO AVOID DAMAGE TO THE FAN

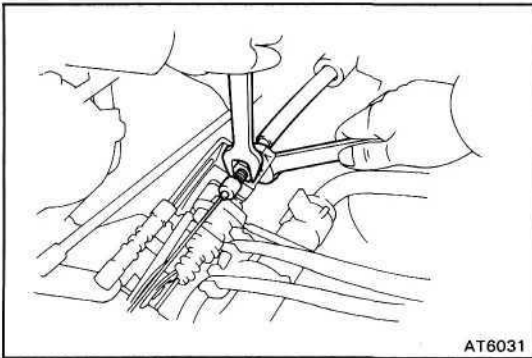

4. DISCONNECT THROTTLE CABLE

- (a) Loosen the adjusting nuts, and disconnect the cable housing from the bracket.
- (b) Disconnect the cable from the throttle linkage.

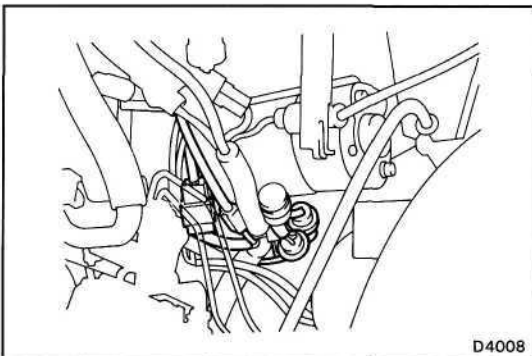

5. DISCONNECT CONNECTORS

Disconnect the connectors near the starter.

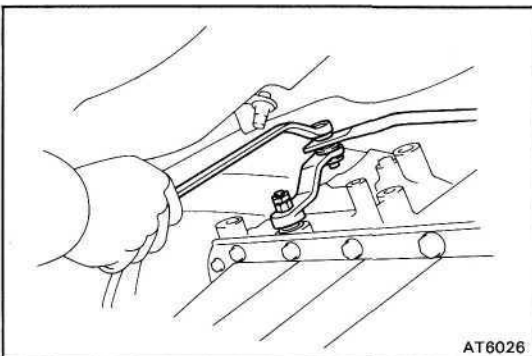

6. REMOVE TRANSFER SHIFT LEVER

- (a) Remove the nut and the transmission control rod.

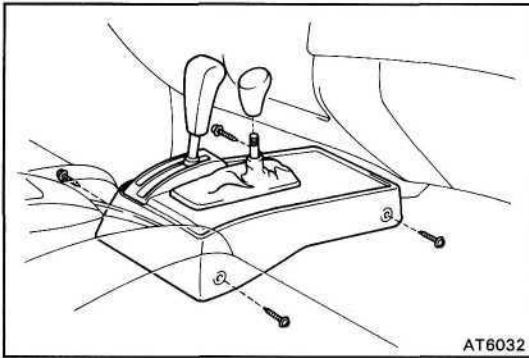

- (b) Remove the transfer shift lever knob.
- (c) Remove four screws and the console.

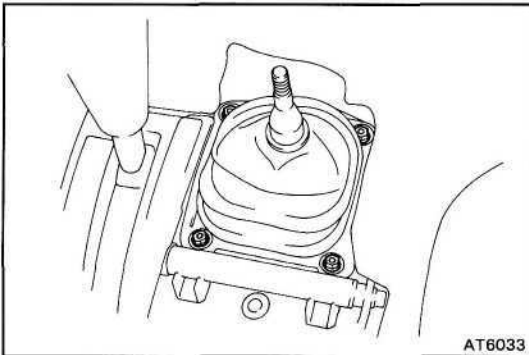

- (d) Remove four bolts and transfer shift lever boot.

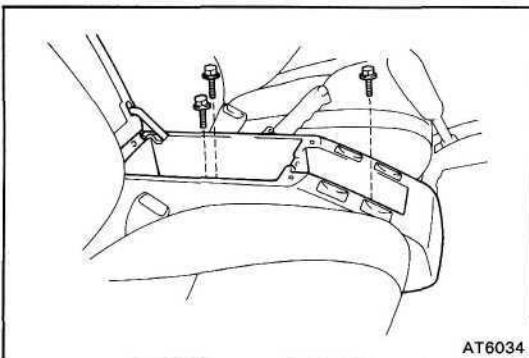

- (e) Remove three bolts and the console box.

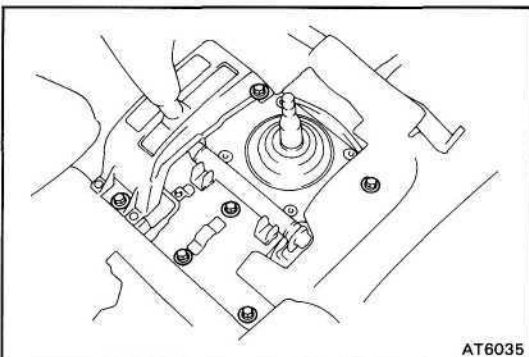

- (f) Remove the six bolts and the transmission shift lever assembly.

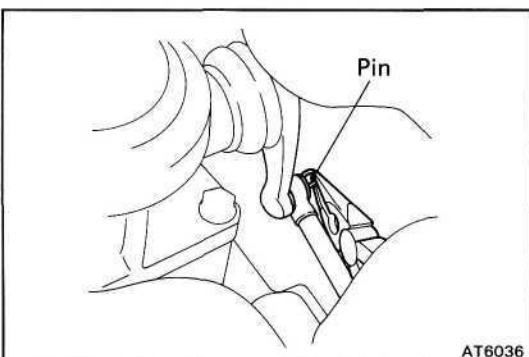

- (g) Pull out the pin and disconnect the shift rod.

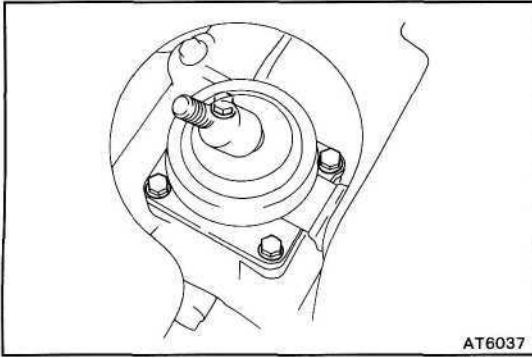

- (h) Remove the four bolts and the transfer shift lever.

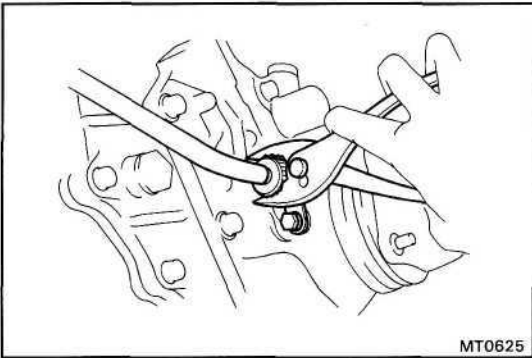

7. DISCONNECT SPEEDOMETER CABLE

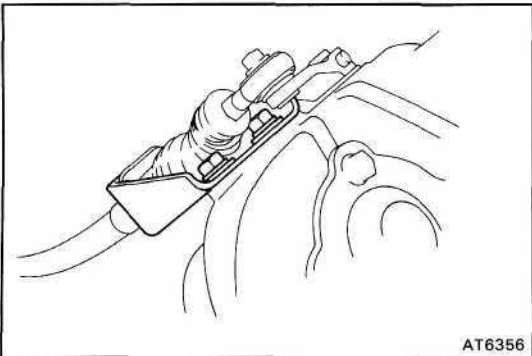

8. REMOVE POWER TAKE-OFF SHIFT CABLE (w/ MECHANICAL WINCH)

- (a) Pull out the pin and disconnect the cable.
 (b) Remove the two bolts and the cable bracket.

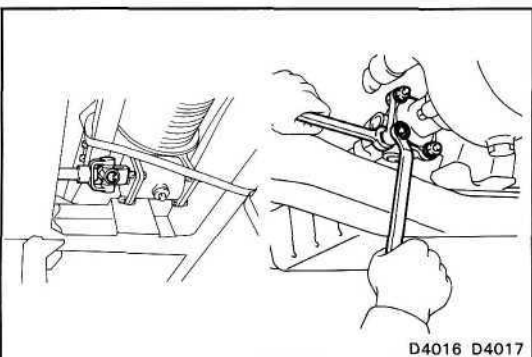

- (c) Remove the engine under cover.
 (d) Place matchmarks on the yoke and flange.
 (e) Remove the bolts and nuts, and disconnect the drive shaft from the PTO.

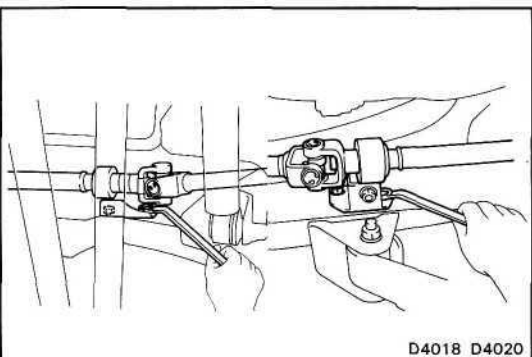

- (f) Remove the front and rear bracket set bolts, and then remove the drive shaft.

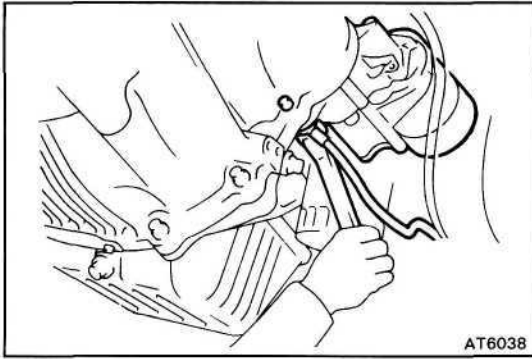
**9. REMOVE PROPELLER SHAFT**

(See page PR-2)

10. REMOVE STARTER

- (a) Disconnect the connector and cable.
- (b) Remove the bolt, nut and starter.

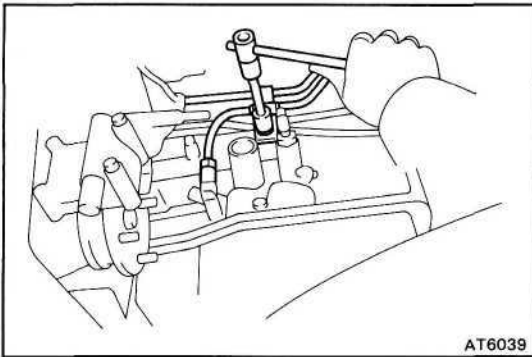
11. REMOVE OIL FILLER TUBE**12. DISCONNECT TWO OIL COOLER TUBES**

- (a) Remove the cooler tube clamp.

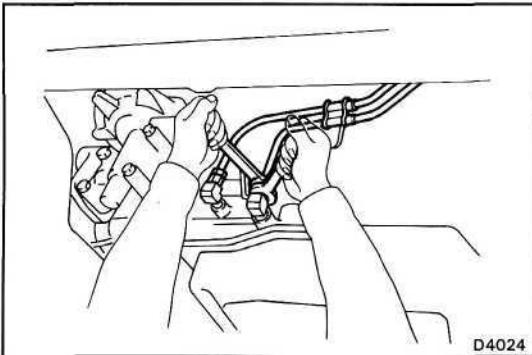

- (b) Disconnect the two oil cooler tubes.

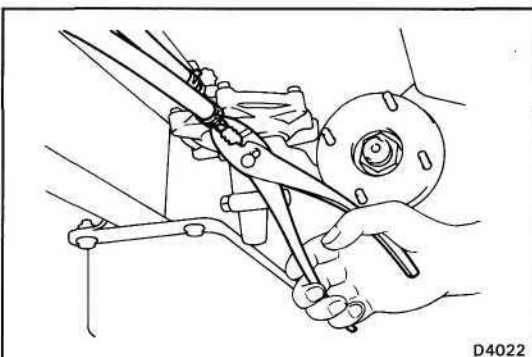
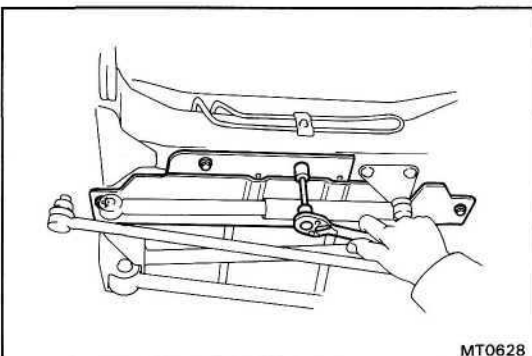
**13. DISCONNECT TWO VACUUM HOSES****14. REMOVE UNDER COVER**

Remove four bolts and the under cover.

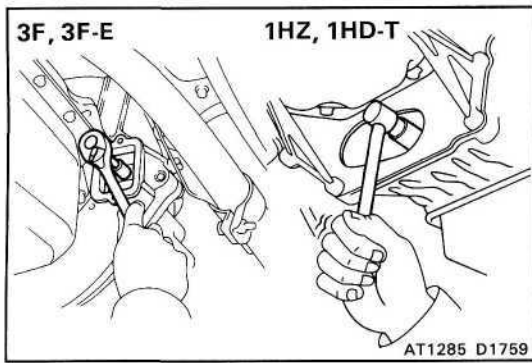
**15. REMOVE SIX TORQUE CONVERTER MOUNTING BOLTS**

- (a) Remove the end plate hole plug.
- (b) Turn the crankshaft to gain access to each bolt. Remove six bolts.

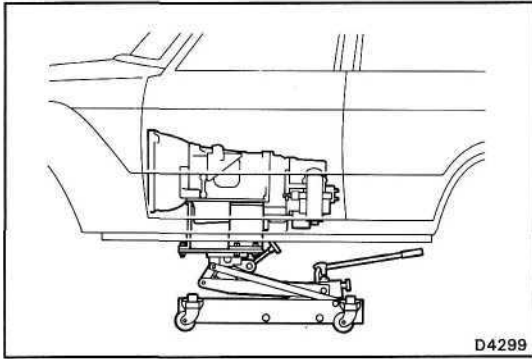
**16. REMOVE FRAME CROSSMEMBER**

- (a) Support the transmission with the transmission jack.

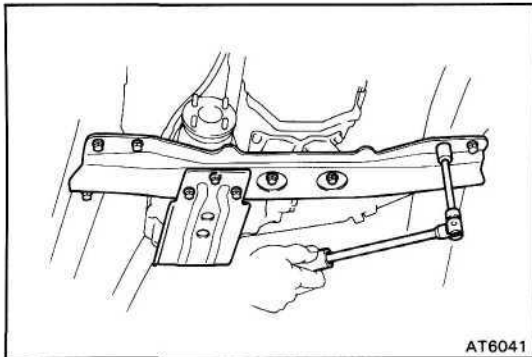

- (b) Remove the eight bolts and two nuts, and then remove the frame crossmember.

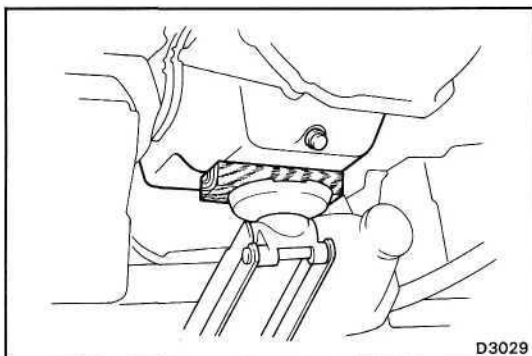
**17. REMOVE TRANSMISSION ASSEMBLY**

- (a) Be sure to put a wooden block or equivalent between the jack and the oil pan to prevent damage. Support the oil pan with a jack.
- (b) Lower the rear end of transmission.

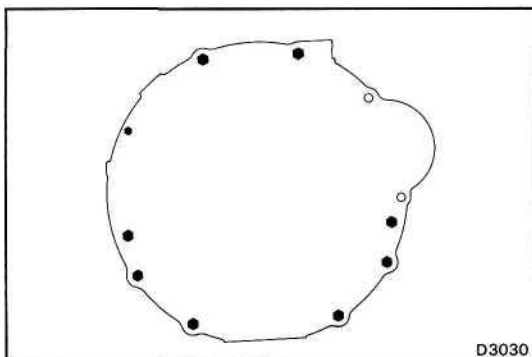

- (c) Remove the nine transmission mounting bolts.
- (d) Draw out the transmission down and toward the rear.

NOTICE: Be careful not to snag the throttle cable or neutral start switch cable. Keep the oil pan positioned downward.

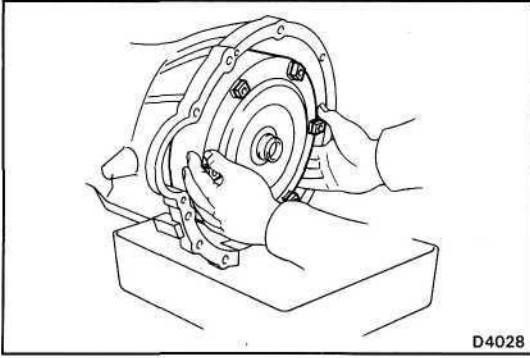

18. PLACE PAN UNDER CONVERTER HOUSING, AND REMOVE CONVERTER

Pull the converter straight off, and allow the fluid to drain into the pan.

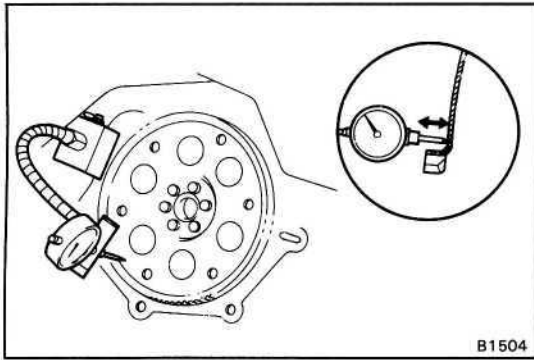

B1504

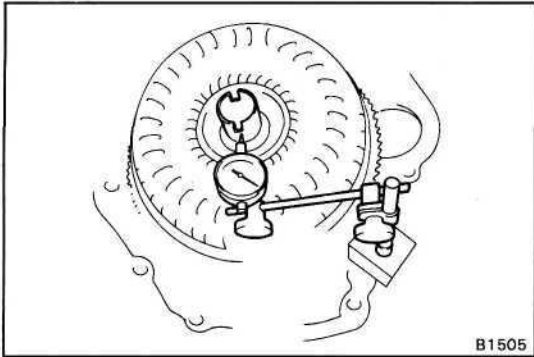

B1505

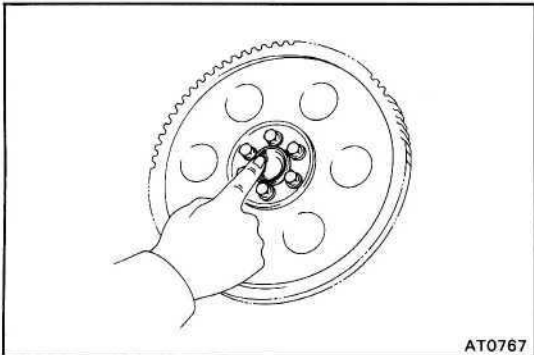

AT0767

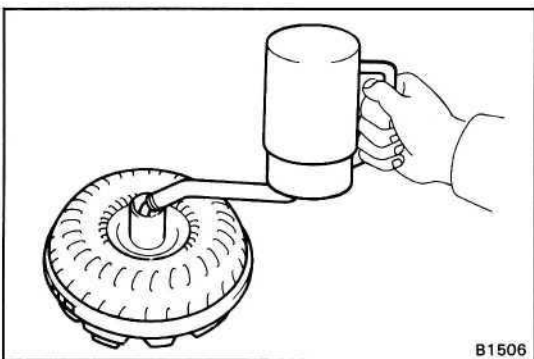

B1506

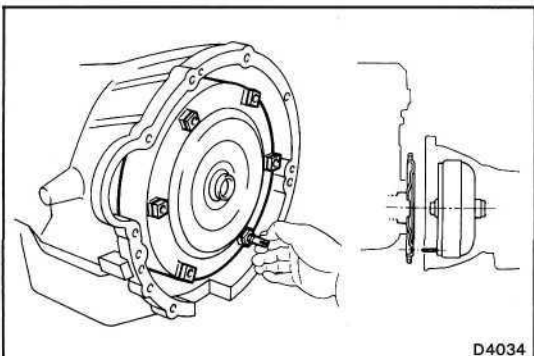

D4034

INSTALLATION OF TRANSMISSION

1. MEASURE DRIVE PLATE RUNOUT AND INSPECT RING GEAR

Set up a dial indicator and measure the drive plate runout.

If runout exceeds 0.20 mm (0.0079 in.) or if the ring gear is damaged, replace the drive plate. If installing a new drive plate, note the orientation of spacers and tighten the bolts.

3F engine 900 kg-cm (65 ft-lb, 88 N-m)

1H engine 1,300 kg-cm (94 ft-lb, 127 N-m)

2. MEASURE TORQUE CONVERTER SLEEVE RUNOUT

(a) Temporarily mount the torque converter to the drive plate. Set up a dial indicator.

If runout exceeds 0.30 mm (0.118 in.), try to correctly by reorienting the installation of the converter. If excessive runout cannot be corrected, replace the torque converter.

HINT: Mark the position of the converter to ensure correct installation.

(b) Remove the torque converter.

3. APPLY GREASE TO CENTER HUB OF TORQUE CONVERTER AND PILOT HOLE IN CRANKSHAFT

4. INSTALL TORQUE CONVERTER IN TRANSMISSION

If the torque converter has been drained and washed, refill with fresh ATF.

**Refill capacity: 2.0 liters
(2.1 USqts, 1.8 Imp. qts)**

**Dry fill capacity: 5.4 liters
(5.7 US qts, 4.8 Imp. qts)**

Fluid type: ATF DEXRON® D

5. INSTALL TRANSMISSION ASSEMBLY

- Install the guide pin in the torque converter.
- Align the guide pin with one of the drive plate holes.
- Align two sleeves on the block with the converter housing.
- Temporarily install one bolt.

NOTICE: Be careful not to tilt the transmission forward because the torque converter could slide out.

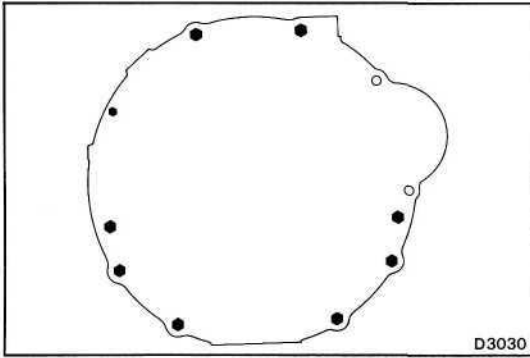

(e) Install the nine transmission mounting bolts.

Torque: 8 mm bolt 185 kg-cm (13 ft-lb, 18 Nm)
 10 mm bolt 380 kg-cm (27 ft-lb, 37 N-m)
 12 mm bolt 730 kg-cm (53 ft-lb, 72 N-m)

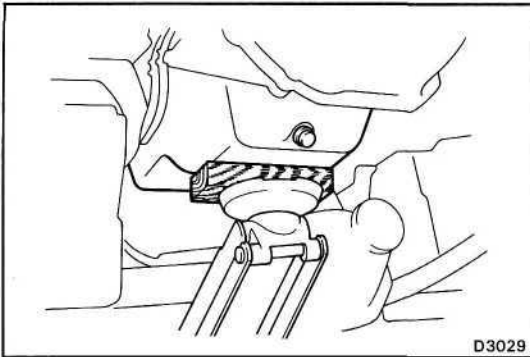

6. INSTALL FRAME CROSSMEMBER

(a) Support the transmission with the transmission jack.

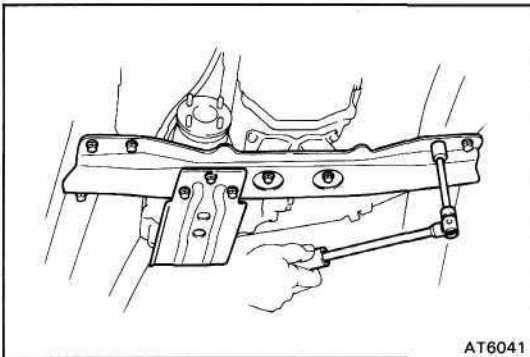

(b) Install the eight bolts and two nuts, and then install the frame crossmember.

Torque: Bolt 620 kg-cm (45 ft-lb, 61 N-m)
 Nut 750 kg-cm (54 ft-lb, 74 N-m)

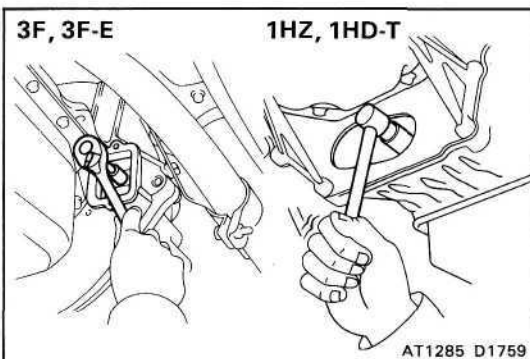

7. INSTALL SIX TORQUE CONVERTER MOUNTING BOLTS

(a) Temporarily install each bolts by turning the crankshaft.

(b) Torque the bolts.

Torque: 3F engine 290 kg-cm (21 ft-lb, 28 N-m)
 1H engine 550 kg-cm (40 ft-lb, 54 N-m)

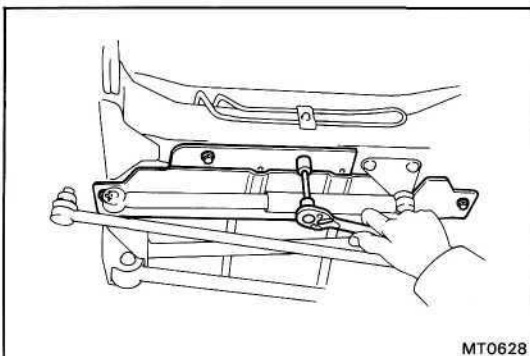

8. INSTALL UNDER COVER

Install the under cover with four bolts.

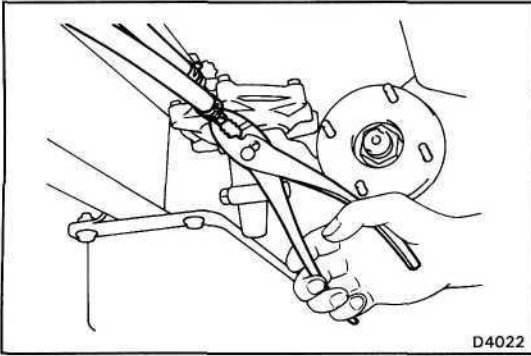

9. CONNECT TWO VACUUM HOSES

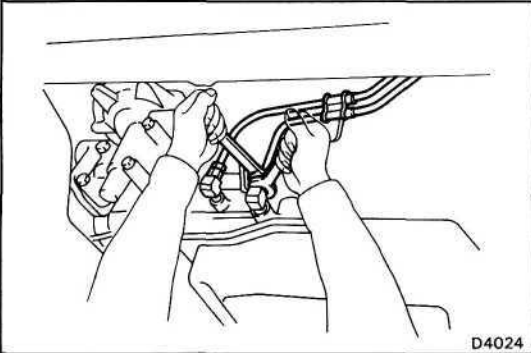

10. CONNECT TWO OIL COOLER TUBES

(a) Connect the two oil cooler tubes.

Torque: 350 kg-cm (25 ft-lb, 34 N-m)

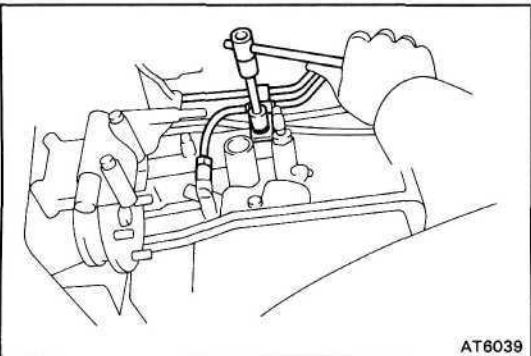

(b) Install the cooler tube clamp.

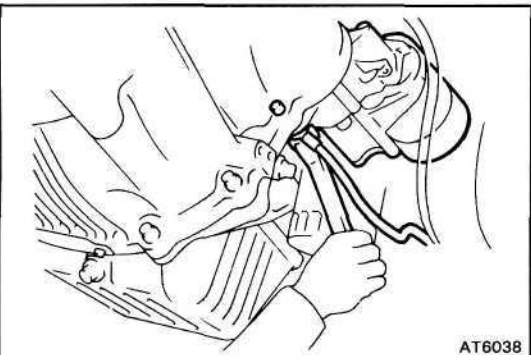

11. INSTALL PROPELLER SHAFT
(See page PR-2)

12. INSTALL STARTER

(a) Install the bolt, nut and starter.

(b) Connect the connector and cable.

13. INSTALL OIL FILLER TUBE

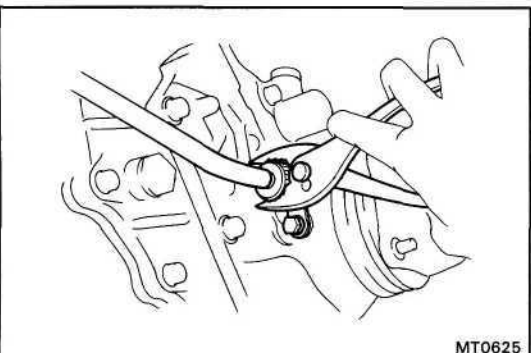

14. CONNECT SPEEDOMETER CABLE

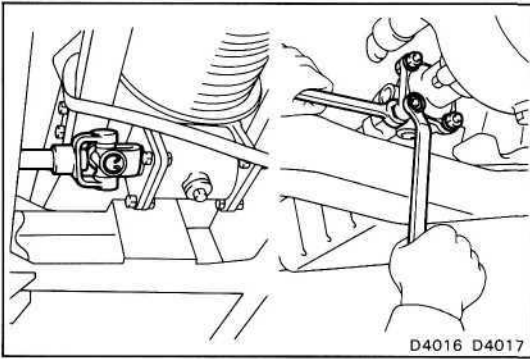

15. INSTALL POWER TAKE-OFF DRIVE SHAFT (w/ MECHANICAL WINCH)

- (a) Align the matchmarks on the joint flange yoke and drive shaft.
- (b) Install the drive shaft.
- (c) Align the matchmarks on the drive shaft and PTO.
- (d) Torque the nuts.

Torque: 200 kg-cm (14 ft-lb, 20 N-m)

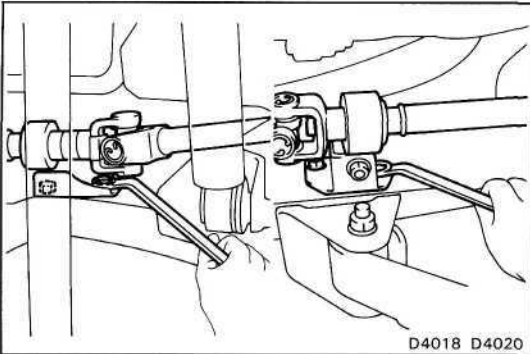

- (e) Install the front and rear bracket.

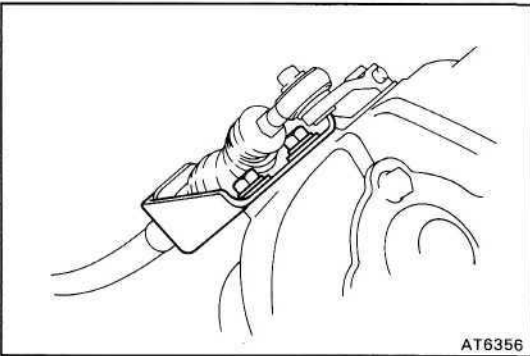

16. INSTALL POWER TAKE-OFF SHIFT CABLE (w/ MECHANICAL WINCH)

- (a) Install the two bolts and the cable bracket.
- (b) Connect the cable and insert the pin.

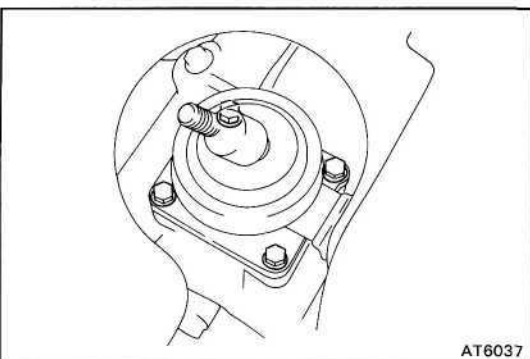

17. INSTALL TRANSFER SHIFT LEVER

- (a) Install the transfer shift lever with four bolts.

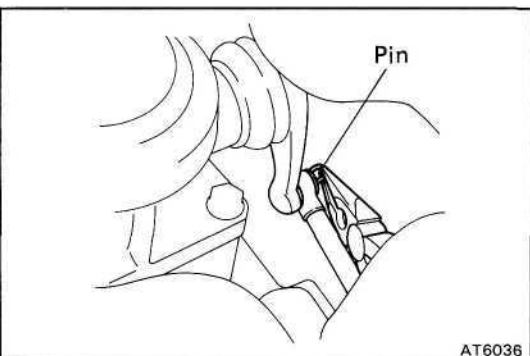

- (b) Connect the shift rod and install the pin.

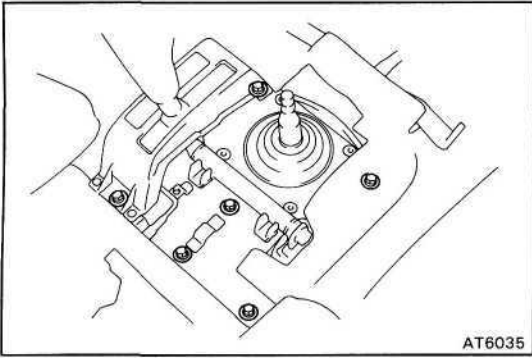

- (c) Install the transmission shift lever assembly with the six bolts.

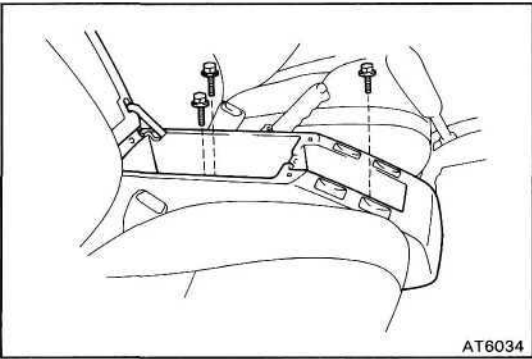

- (d) Install the console box with three bolts.

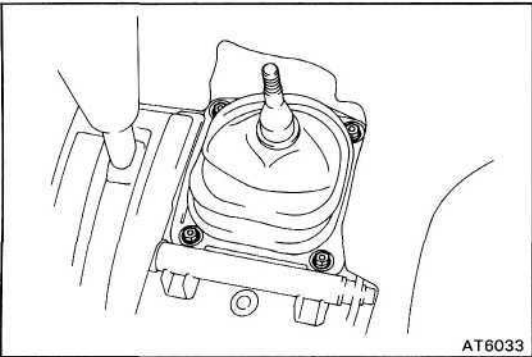

- (e) Install the transfer shift lever boot with the four bolts.

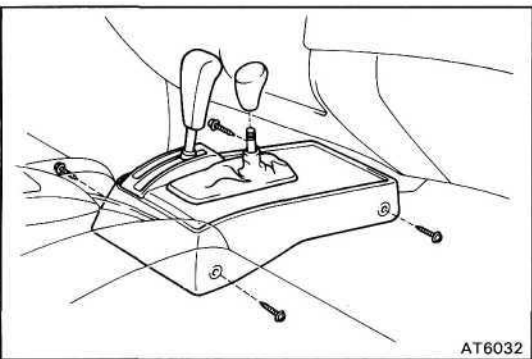

- (f) Install the console with the four screws.
 (g) Install the transfer shift lever knob.

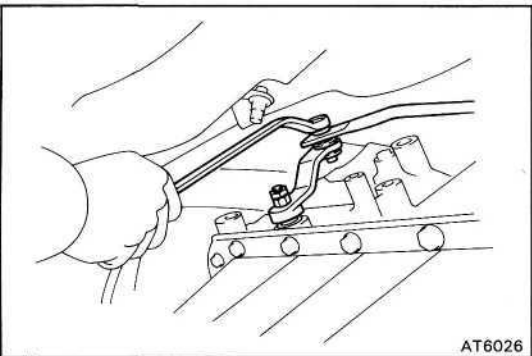

- (h) Install the transmission control rod with the nut.

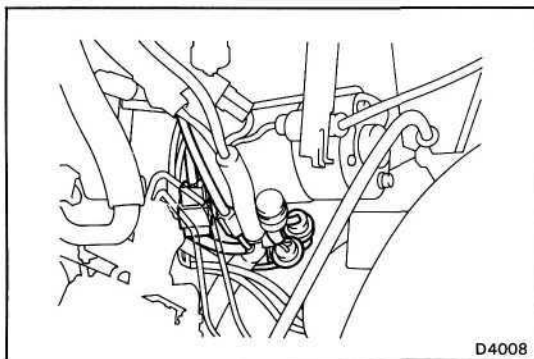

D4008

18. CONNECT CONNECTORS

Connect the connectors near the starter.

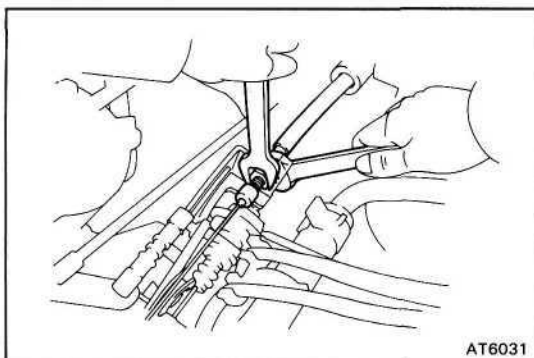

AT6031

19. CONNECT THROTTLE CABLE

- (a) Connect the cable to the throttle linkage.
- (b) Connect the cable housing to the bracket and tighten the adjusting nut.

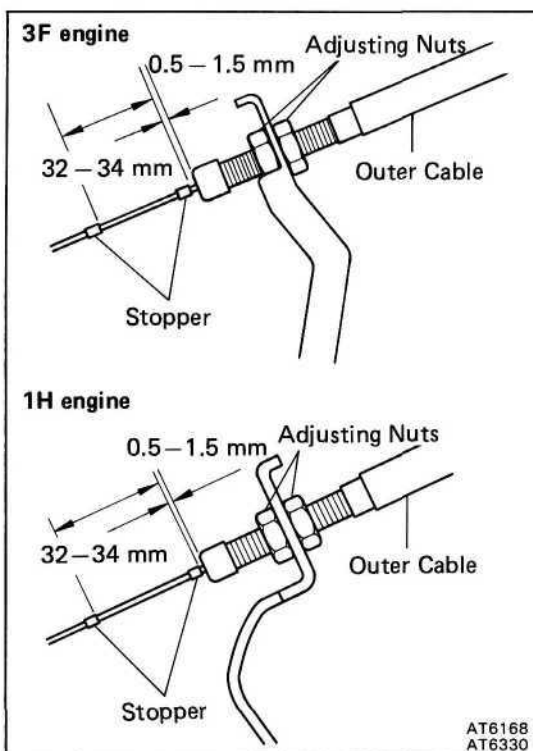
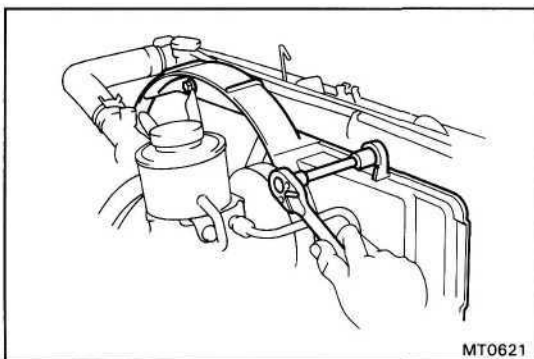
AT6168
AT6330**20. ADJUST THROTTLE CABLE**
(See page AT-13)

MT0621

- 21. TIGHTEN THE FAN SHROUD OF THE COOLING FAN**
- 22. INSTALL BATTERY AND COVER**
- 23. CONNECT BATTERY CABLE TO NEGATIVE TERMINAL**