

MANUAL TRANSMISSION (H140F, H150F AND H151F TRANSMISSIONS)

| | Page |
|--|-------|
| DESCRIPTION..... | MT-2 |
| PRECAUTIONS..... | MT-4 |
| TROUBLESHOOTING..... | MT-4 |
| REMOVAL AND INSTALLATION OF TRANSMISSION..... | MT-5 |
| COMPONENTS..... | MT-12 |
| DISASSEMBLY OF TRANSMISSION..... | MT-15 |
| COMPONENT PARTS..... | MT-25 |
| Input Shaft Assembly..... | MT-25 |
| Output Shaft Assembly..... | MT-27 |
| Counter Gear Assembly..... | MT-39 |
| Front Bearing Retainer..... | MT-42 |
| Oil Pump Cover Assembly..... | MT-43 |
| ASSEMBLY OF TRANSMISSION..... | MT-47 |

MT

DESCRIPTION

- Transmission types, H140F, H150F and H151F are constant mesh synchronizer for forward gears and a sliding mesh reverse gear.

H140F

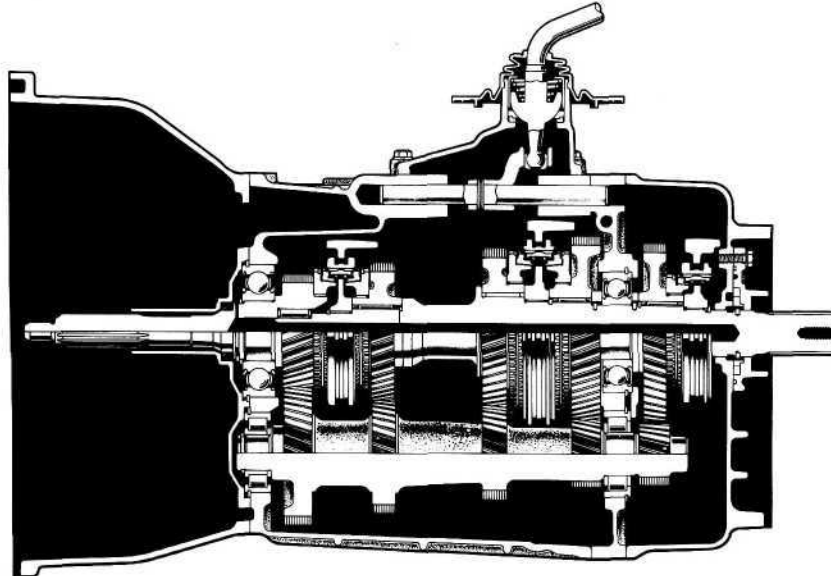

HM0535

H150F

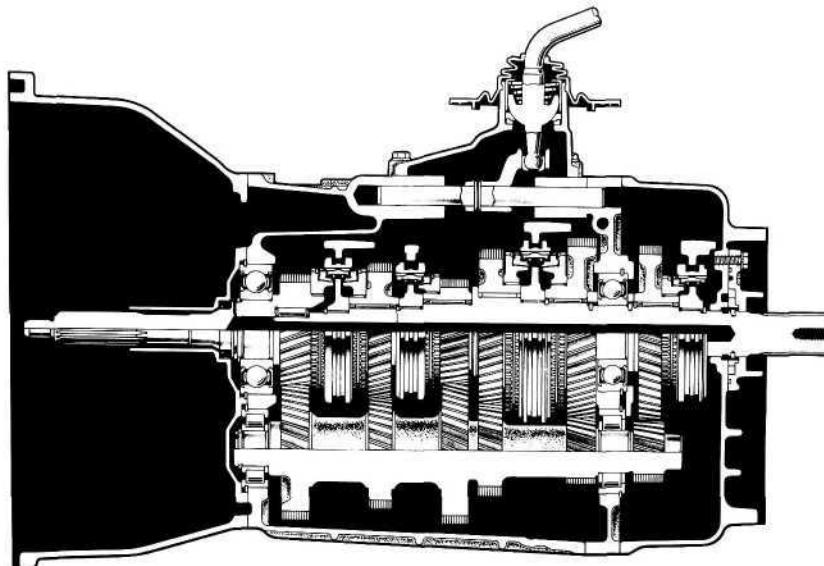

HM0520

H151F

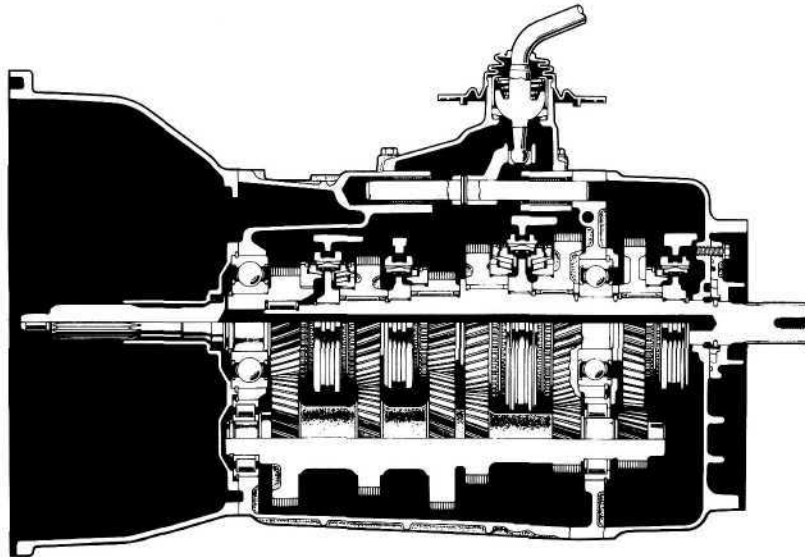

HM0521

Specifications

| Type of Transmission | | H140F | H150F | H151F |
|----------------------|--------------|--------------------------------------|-------|-------|
| Type of Engine | | 3F, 1HZ | | 1HD-T |
| Gear Ratio | 1 st | 4.529 | ← | 4.081 |
| | 2 nd | 2.464 | ← | 2.294 |
| | 3 rd | 1.490 | ← | ← |
| | 4 th | 1.000 | ← | ← |
| | 5 th | — | 0.881 | ← |
| | Rev. | 4.313 | ← | ← |
| Oil Capacity | H140F | 2.7 liters (2.8 Us qts, 2.4 Imp.qts) | | |
| | H150F, H151F | 2.6 liters (2.7 Us qts, 2.3 Imp.qts) | | |
| Type of Oil | | API GL-4 or GL-5 SAE 75W-90 | | |

PRECAUTIONS

When working with FIPG material, you must observe the following.

- Using a razor blade and gasket scraper, remove all the old packing (FIPG) material from the gasket surfaces.
- Thoroughly clean all components to remove all the loose material.
- Clean both sealing surfaces with a non-residue solvent.
- Apply the seal packing in approx. 1.2 mm (0.047 in.) bead along the sealing surface.
- Parts must be assembled within 10 minutes of application. Otherwise, the packing (FIPG) material must be removed and reapplied.

TROUBLESHOOTING

| Problem | Possible cause | Remedy | Page |
|---------------------------------|--|--------------------------------------|------|
| Hard to shift or will not shift | Splines on input shaft dirty or burred | Repair as necessary | MT-5 |
| | Transmission faulty | Disassemble and inspect transmission | MT-5 |
| Transmission jumps out of gear | Transmission faulty | Disassemble and inspect transmission | MT-5 |

REMOVAL AND INSTALLATION OF TRANSMISSION COMPONENTS

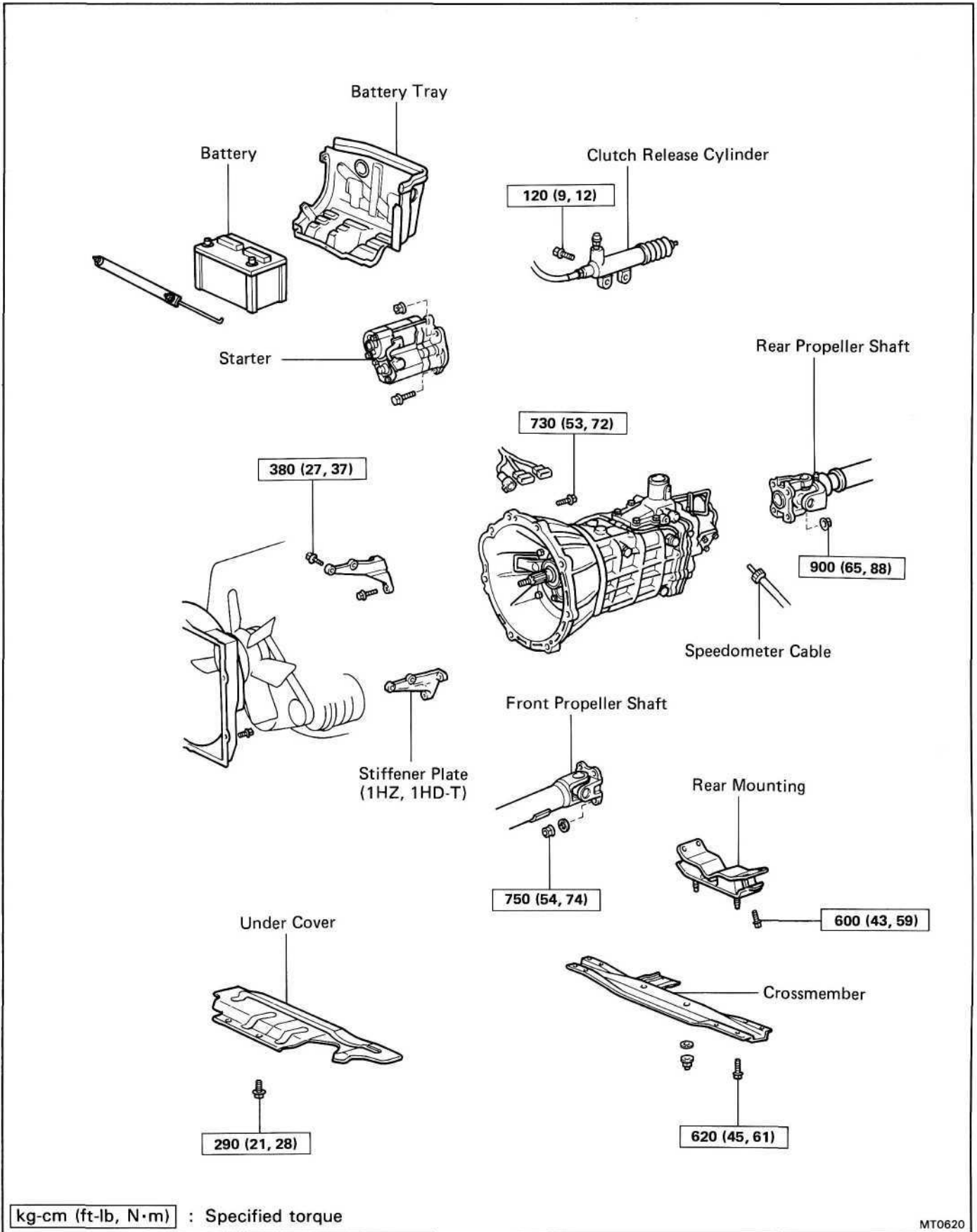

REMOVAL OF TRANSMISSION

1. DISCONNECT BATTERY CABLE FROM NEGATIVE TERMINAL
2. REMOVE BATTERY AND COVER

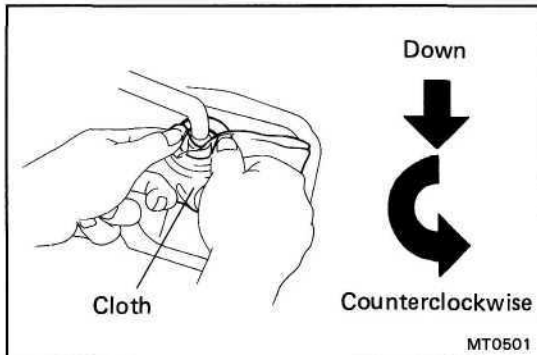

3. REMOVE SHIFT LEVER FROM INSIDE OF VEHICLE
 - (a) Remove the shift lever knob.
 - (b) Remove the two screws and remove the shift lever boot retainer.
 - (c) Pull up the shift lever boot.
 - (d) Cover the shift lever cap with a cloth.
 - (e) Then, pressing down on the shift lever cap rotate it counterclockwise to remove.
 - (f) Remove the shift lever.

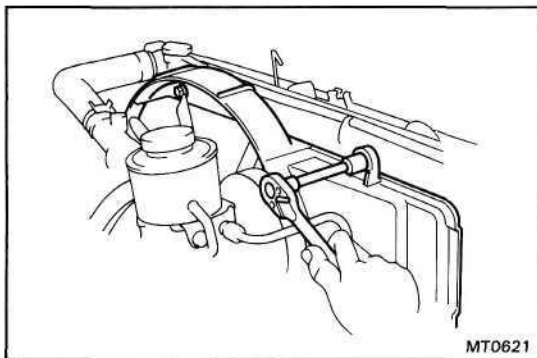

4. LOOSEN FAN SHROUD OF COOLING FAN TO AVOID DAMAGE TO FAN
5. RAISE VEHICLE

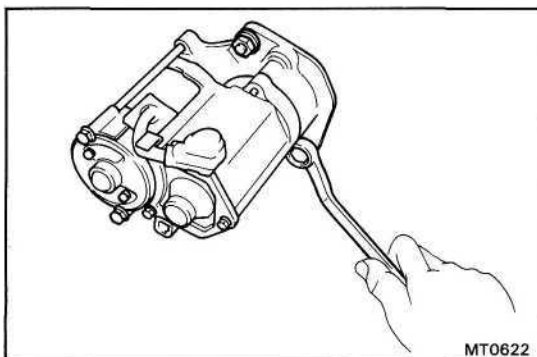

6. DISCONNECT PROPELLER SHAFT
(See page PR-2)
7. REMOVE STARTER
Remove the bolt, nut and the starter.

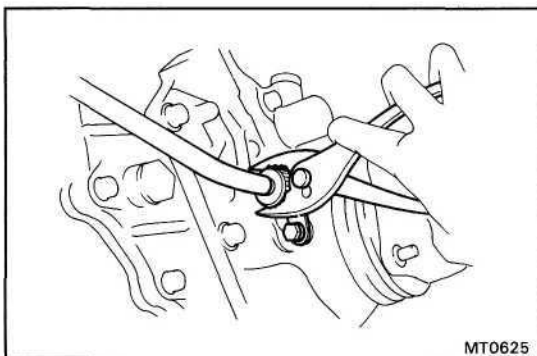

8. DISCONNECT SPEEDOMETER CABLE

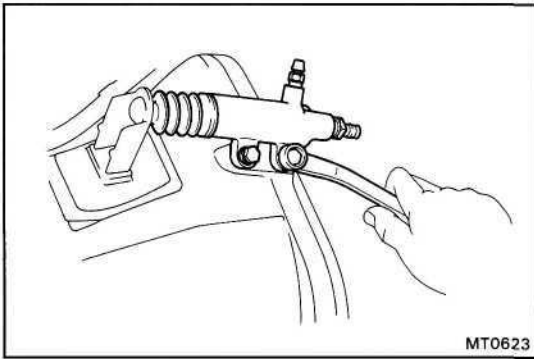
**9. DISCONNECT BACK-UP LIGHT SWITCH CONNECTOR****10. DISCONNECT RELEASE CYLINDER FROM TRANSMISSION**

Remove the two mounting bolts and release cylinder alongside the engine.

HINT: Do not disconnect the clutch line.

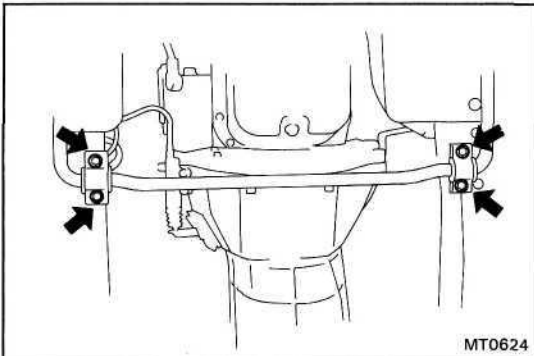
**11. REMOVE STABILIZER BRACKET**

Remove four stabilizer bracket set bolts.

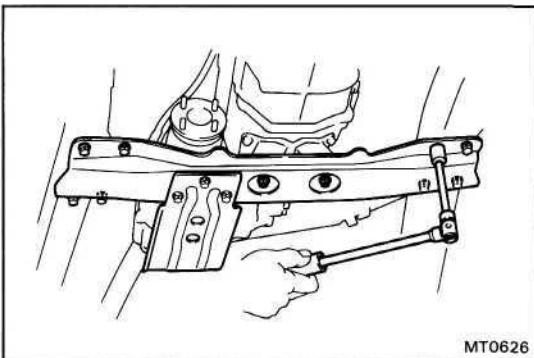
**12. SUPPORT TRANSMISSION WITH JACK****13. REMOVE CROSSMEMBER AND REAR MOUNTING**

(a) Remove the eight bolts, two nuts and crossmember.

(b) Remove the four bolts and rear mounting from the transmission.

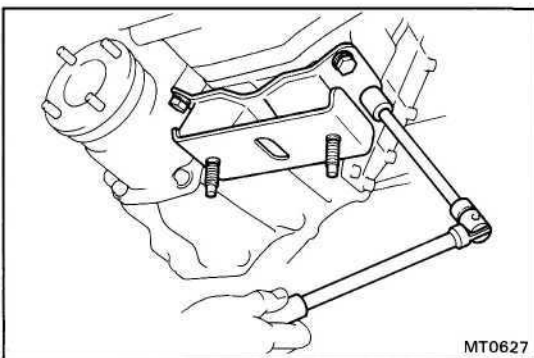
**14. (1HZ, 1HD-T)
REMOVE STIFFENER PLATE BOLTS**

Remove the four stiffener plate bolts from the transmission.

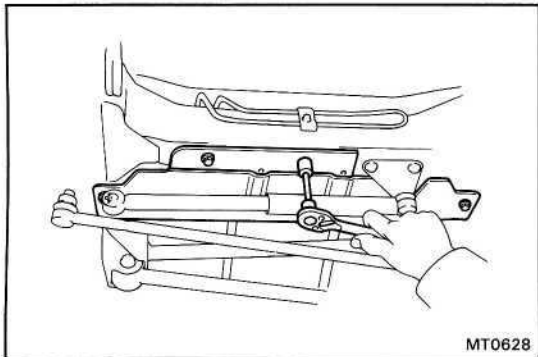
**15. JACK UP FRONT SIDE OF ENGINE**

(a) Remove the four set bolts and engine under cover.

(b) Jack up the front side of engine.

16. REMOVE REMAINING TRANSMISSION BOLTS**17. REMOVE TRANSMISSION**

Remove transmission toward the rear.

18. REMOVE TRANSFER FROM TRANSMISSION

(a) Remove the transfer adaptor rear mounting bolts.

(b) Remove the transfer from the transmission.

INSTALLATION OF TRANSMISSION

1. INSTALL TRANSFER TO TRANSMISSION

- (a) Install the transfer to the transmission.
- (b) Install the transfer adaptor rear mounting bolts.

2. PLACE TRANSMISSION AT INSTALLATION POSITION

Align the input shaft spline with the clutch disc, and push the transmission fully into position.

3. INSTALL TRANSMISSION BOLTS

Torque: 730 kg-cm (53 ft-lb, 72 N-m)

4. (1HZ, 1HD-T) INSTALL STIFFENER PLATES

Torque: 380 kg-cm (27 ft-lb, 37 N-m)

5. INSTALL ENGINE REAR MOUNTING AND CROSSMEMBER

- (a) Install the mounting with four bolts to the transmission.

Torque: 600 kg-cm (43 ft-lb, 59 N-m)

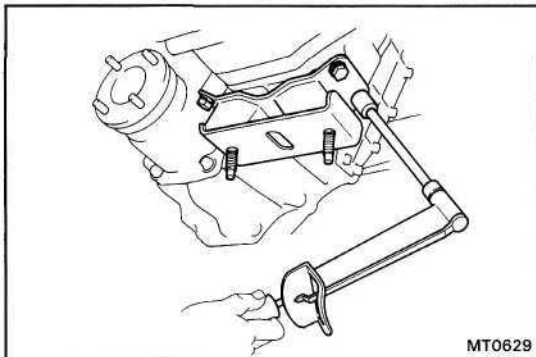

- (b) Install the crossmember with eight bolts and two nuts.

Torque: 620 kg-cm (45 ft-lb, 61 N-m)

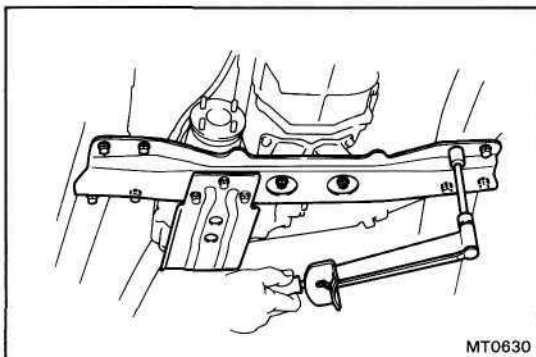

6. REMOVE JACK

7. INSTALL ENGINE UNDER COVER

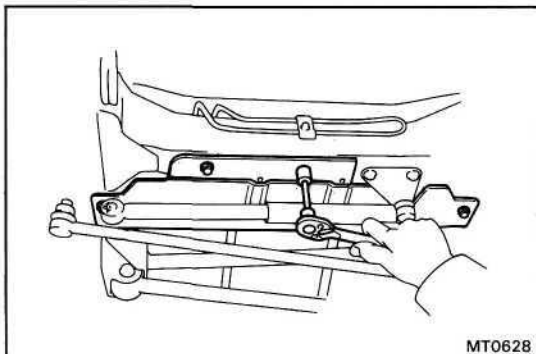

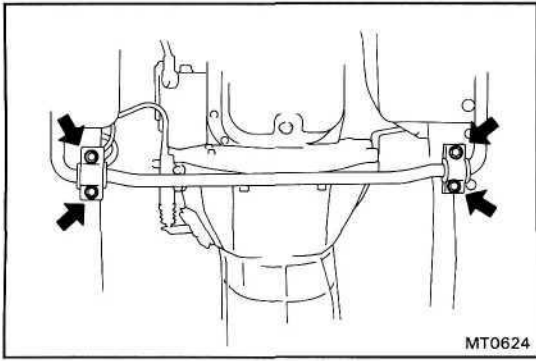
**8. INSTALL STABILIZER BRACKET**

Install the stabilizer bracket with four bolts.

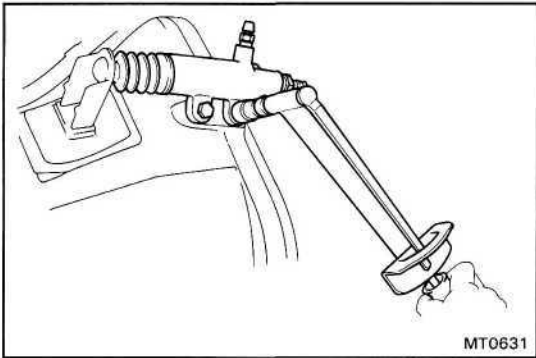
**9. INSTALL CLUTCH RELEASE CYLINDER**

Install the release cylinder with two bolts.

Torque: 120 kg-cm (9 ft-lb, 12 N-m)

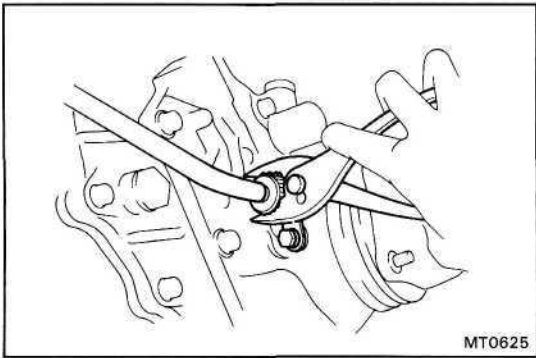
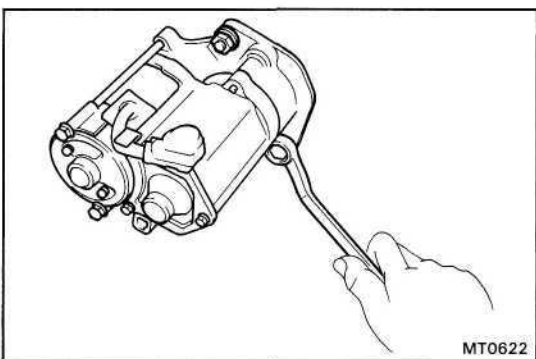
**10. CONNECT BACK-UP LIGHT SWITCH CONNECTOR****11. CONNECT SPEEDOMETER CABLE****12. INSTALL STARTER**

Install the starter with bolt and nut.

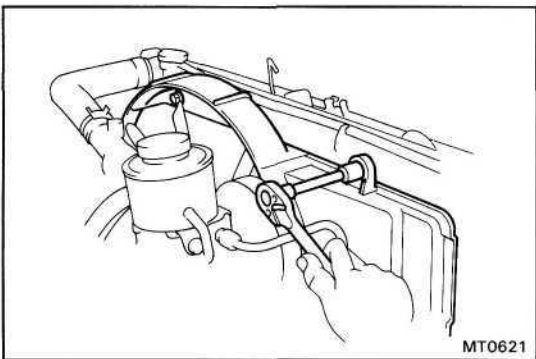
**13. CONNECT PROPELLER SHAFT**
(See page PR-2)**14. LOWER VEHICLE****15. TIGHTEN FAN SHROUD**

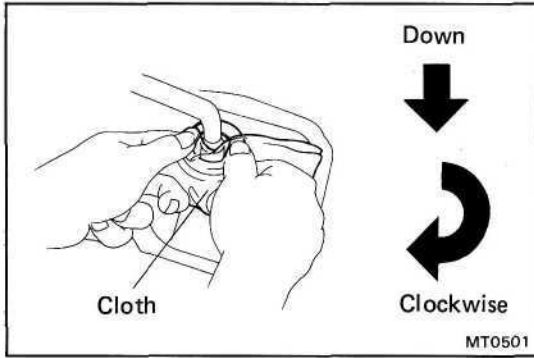
**16. INSTALL SHIFT LEVER**

- (a) Apply MP grease to the shift lever.
- (b) Align the groove of the shift lever cap and the pin part of case cover.
- (c) Cover the shift lever cap with a cloth.
- (d) Then, pressing down on the shift lever cap rotate it clockwise to install.
- (e) Install the shift lever boot and retainer with four screws.
- (f) Install the shift lever knob.

17. CONNECT BATTERY CABLE TO NEGATIVE TERMINAL**18. PERFORM ROAD TEST**

Check for abnormal noise and smooth operation.

COMPONENTS (H140F, H150F AND H151F TRANSMISSIONS) COMPONENTS

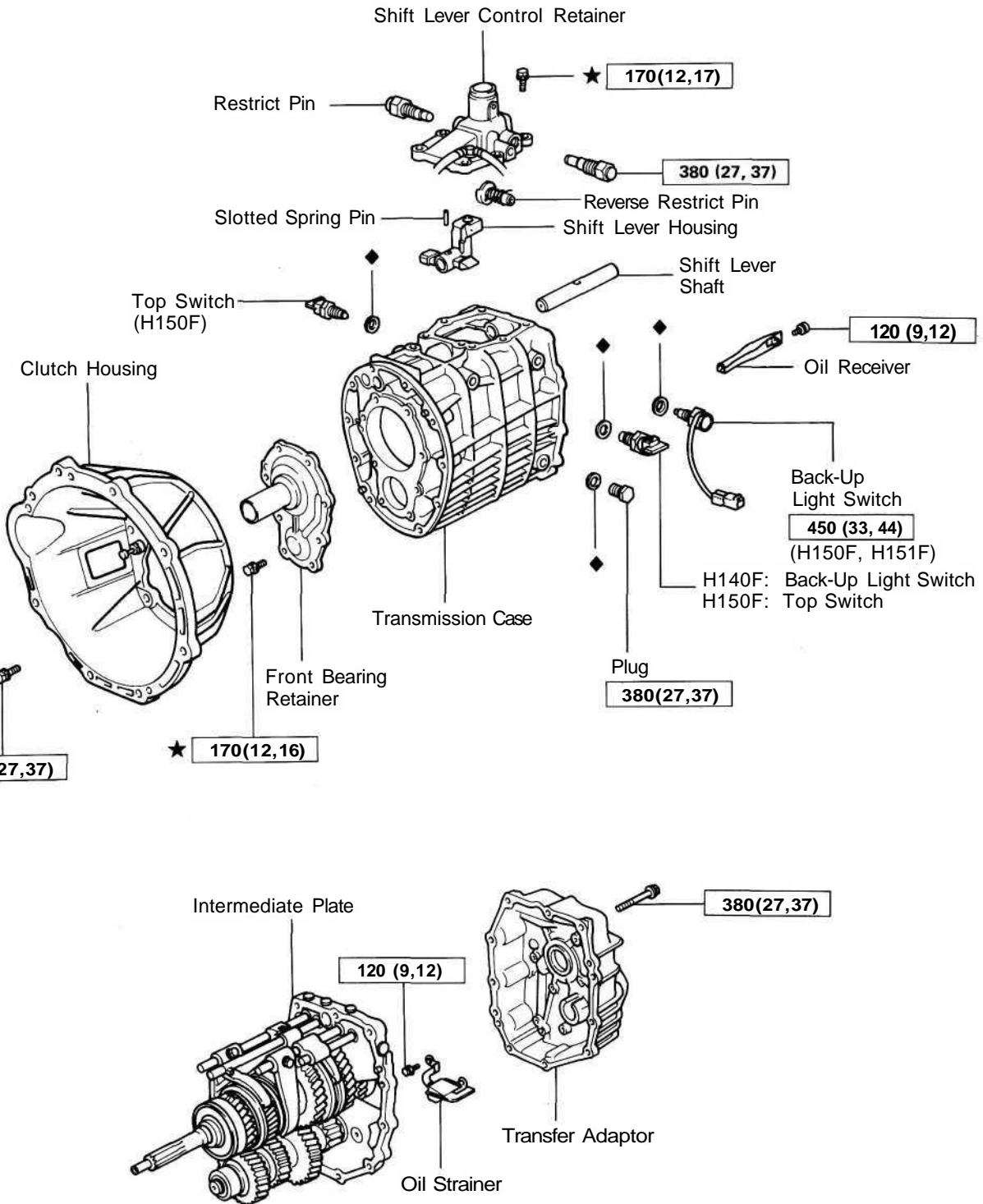

kg-cm (ft-lb, N-m) : Specified torque

◆ Non-reusable part

★ Precoated part

COMPONENTS (Cont'd)

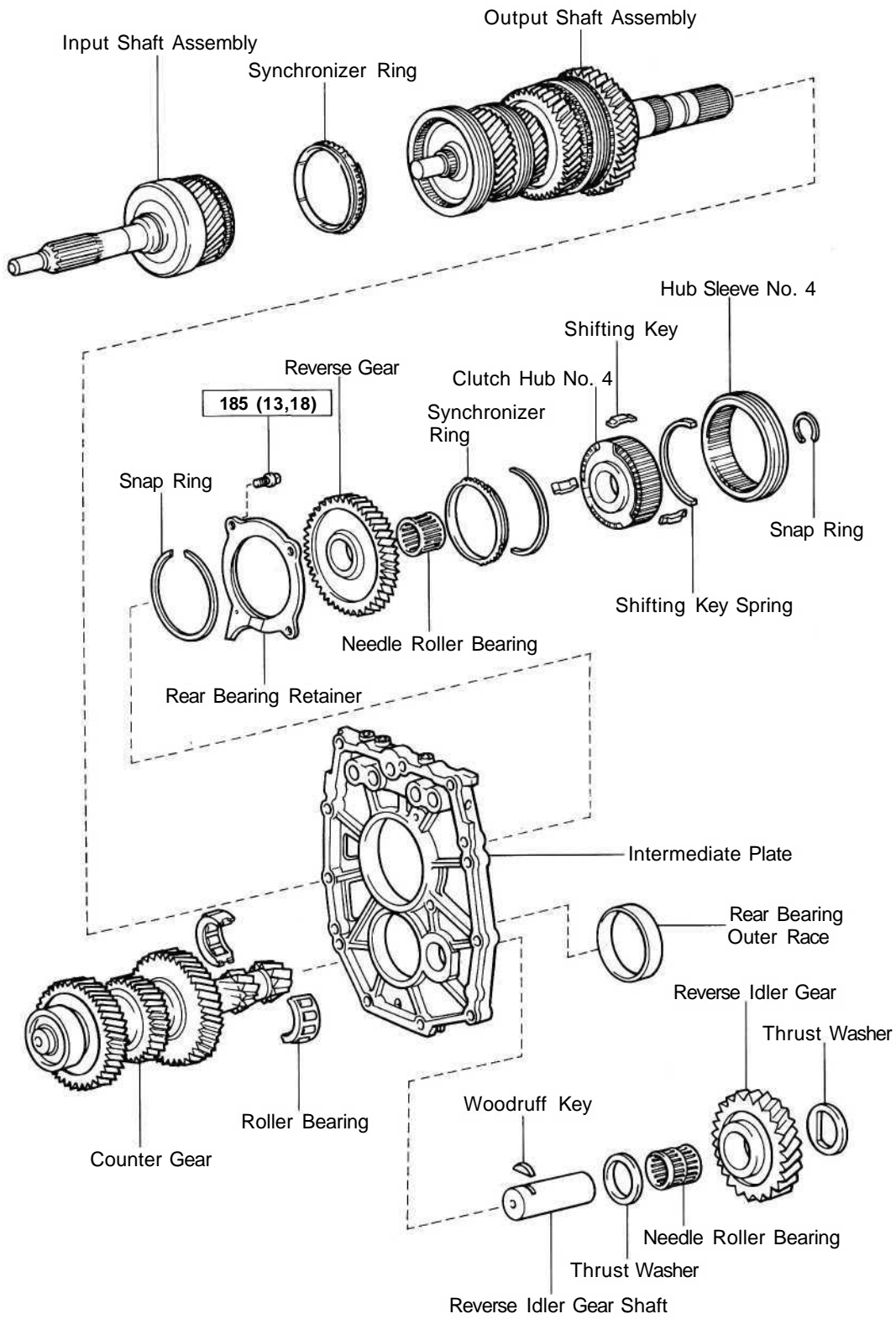

kg-cm (ft-lb, N-m) : Specified torque

COMPONENTS (Cont'd)

4-Speed (H140F)

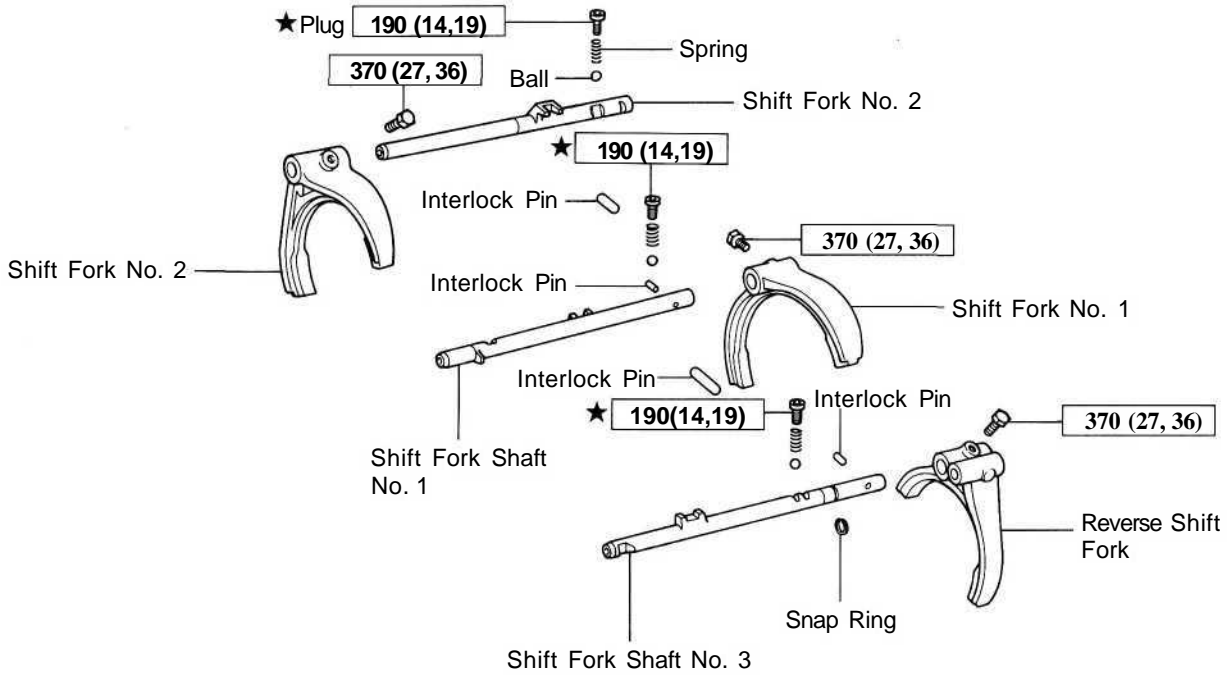

5-Speed(H150F, H151F)

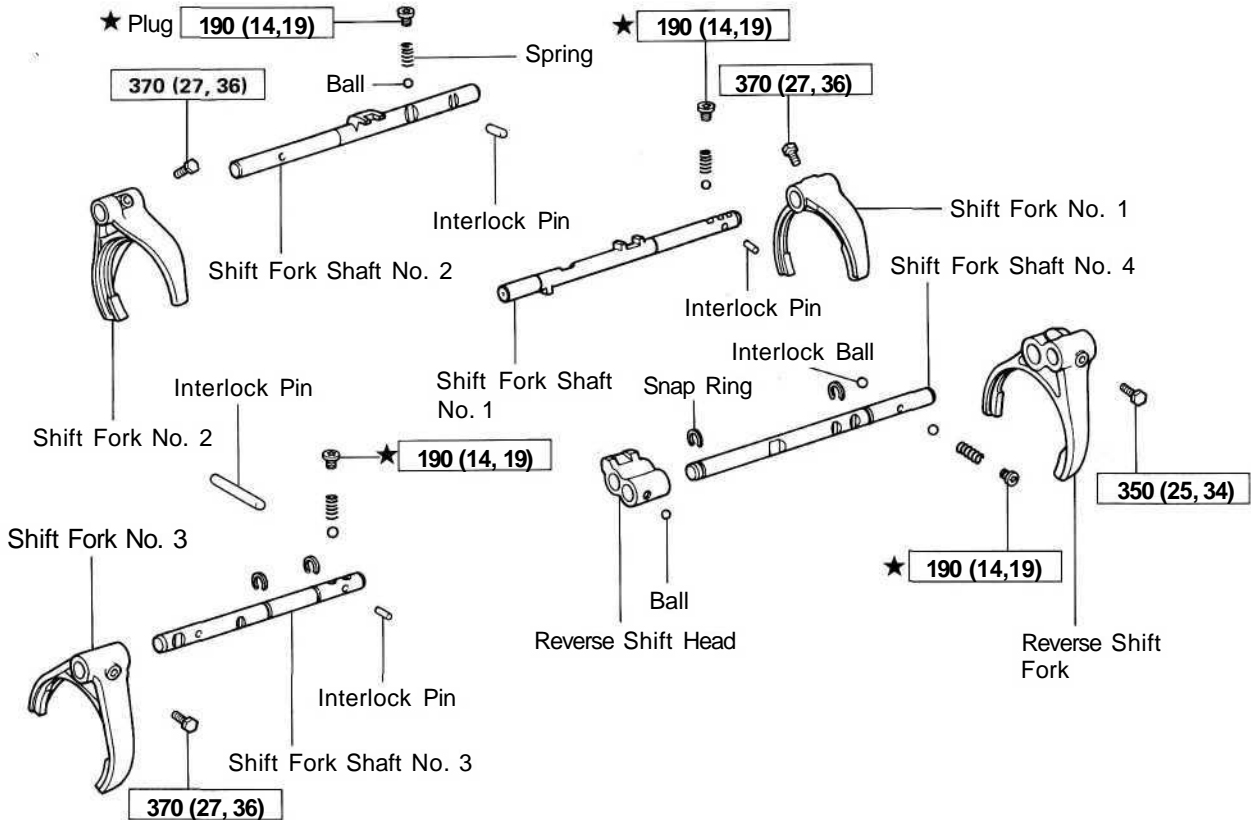

kg-cm (ft-lb, N-m) : Specified torque

★ Precoated part

DISASSEMBLY OF TRANSMISSION

(See page MT-12 to 14)

1. REMOVE RELEASE FORK AND BEARING
2. REMOVE BACK-UP LIGHT SWITCH

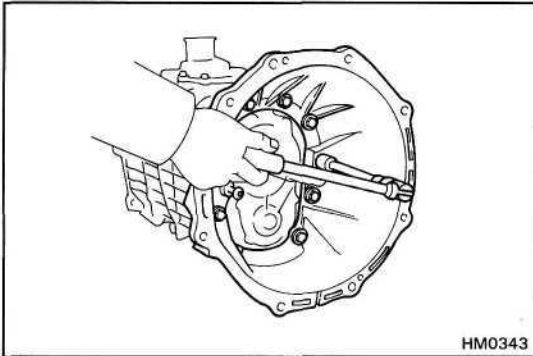

HM0343

3. REMOVE CLUTCH HOUSING FROM TRANSMISSION CASE

Remove the ten bolts and clutch housing.

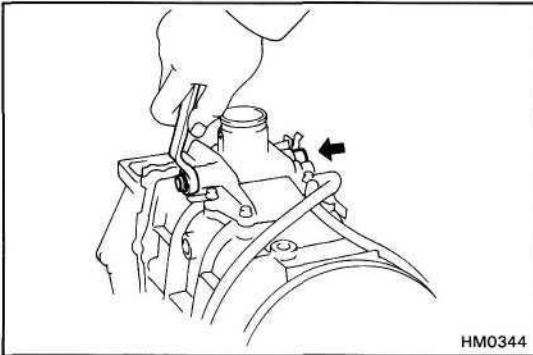

HM0344

4. REMOVE TWO RESTRICT PINS
5. REMOVE BREATHER HOSE

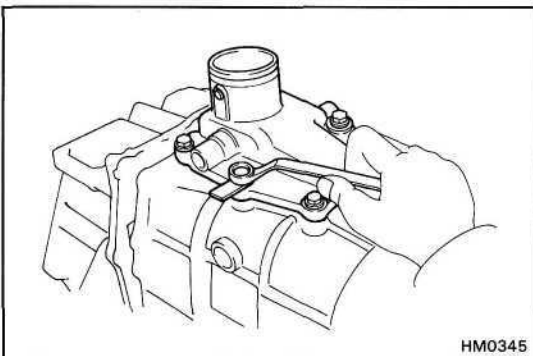

HM0345

6. REMOVE SHIFT LEVER CONTROL RETAINER

Remove the six bolts and transmission shift lever control retainer.

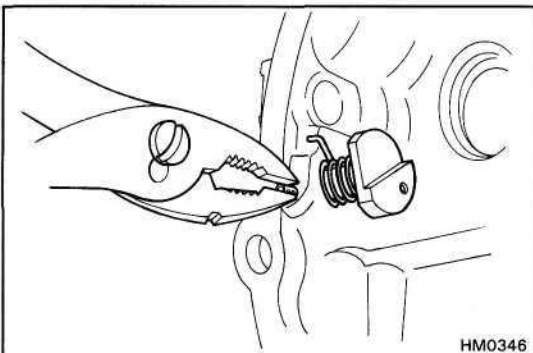

HM0346

7. REMOVE REVERSE RESTRICT PIN

(a) Using pliers, remove the slotted spring pin.

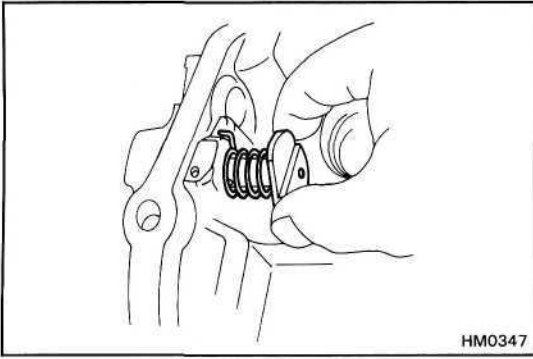

(b) Remove the reverse restrict pin.

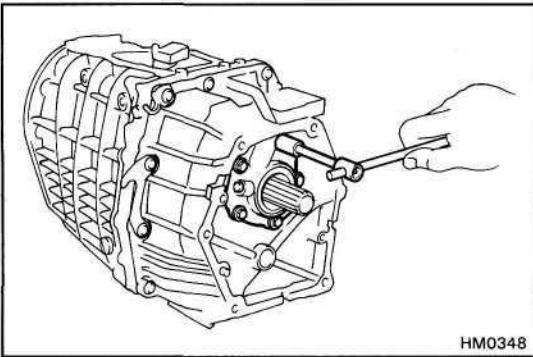

8. REMOVE OIL PUMP COVER ASSEMBLY

(a) Remove the five bolts and oil pump cover.

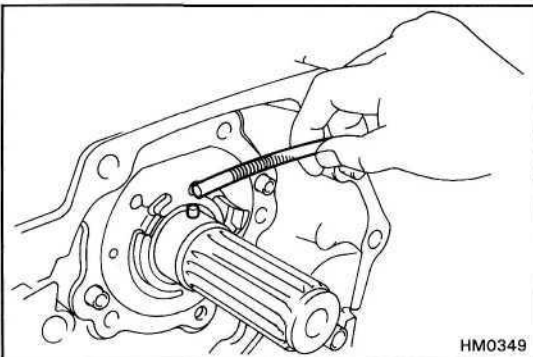

(b) Using a magnetic finger, remove the two straight pins.

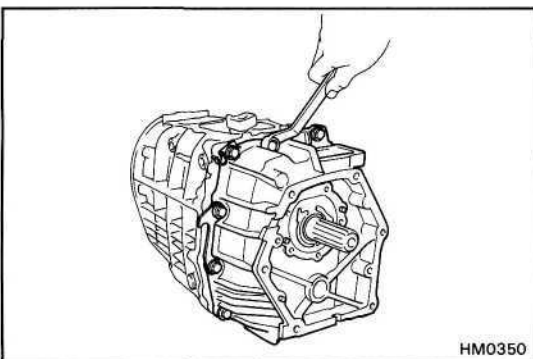

9. REMOVE TRANSFER ADAPTOR

Remove the eleven bolts.

HINT: If necessary, tap the transfer adaptor with a plastic hammer.

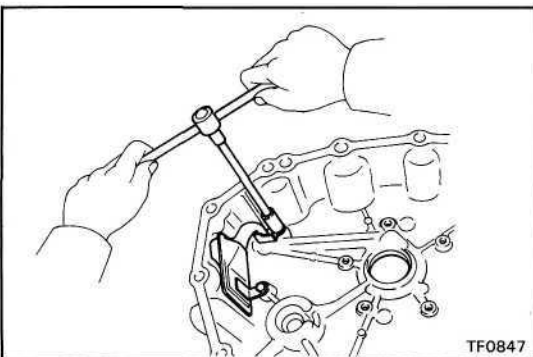

10. REMOVE OIL STRAINER FROM TRANSFER ADAPTOR

Remove the two bolts and oil strainer.

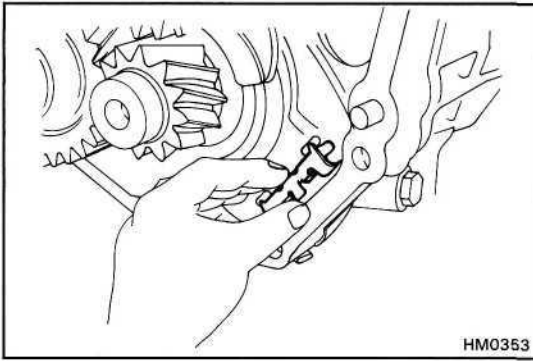
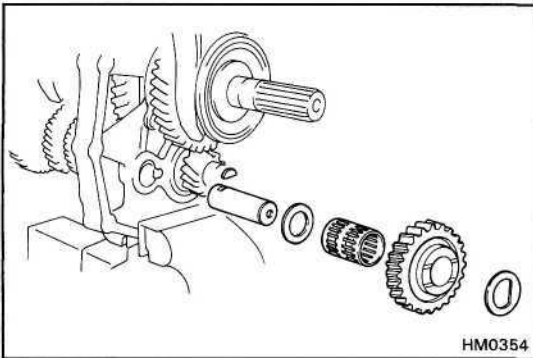
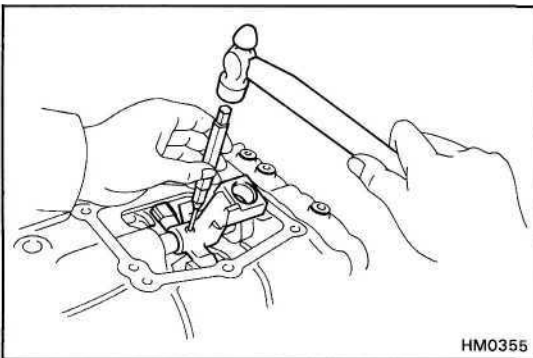
**11. REMOVE MAGNET FROM INTERMEDIATE PLATE****12. REMOVE REVERSE IDLE GEAR FROM INTERMEDIATE PLATE****13. REMOVE SHIFT LEVER SHAFT AND SHIFT LEVER HOUSING**

- (a) Using a pin punch and a hammer, drive out the slotted spring pin from the shift lever housing.

- (b) Remove the shift lever shaft and shift lever housing.

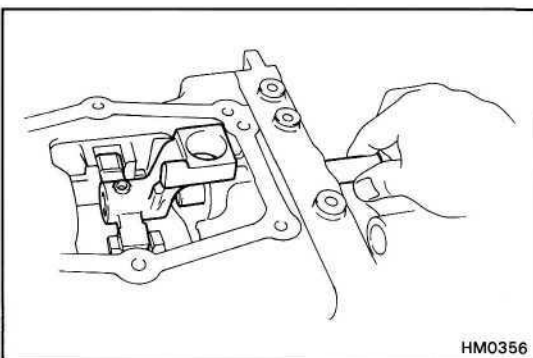
**14. REMOVE FRONT BEARING RETAINER**

- (a) Remove the eight bolts, and front bearing retainer.

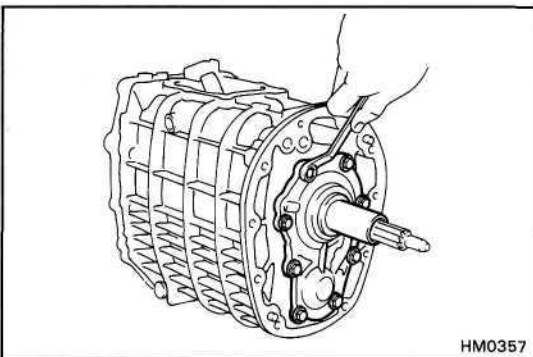

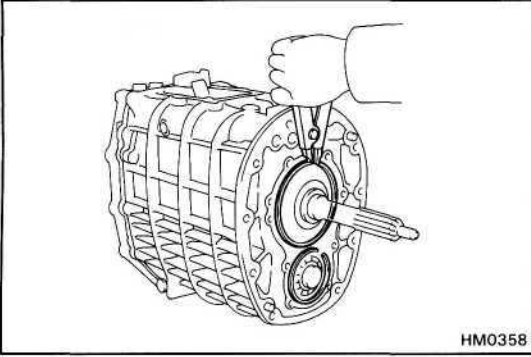

- (b) Using snap ring pliers, remove the two snap rings from the input shaft and counter gear.

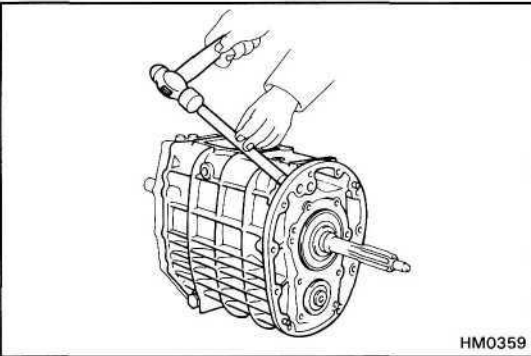

15. SEPARATE TRANSMISSION CASE FROM INTERMEDIATE PLATE

- (a) Using a brass bar and a hammer, carefully tap off the transmission case.
 (b) Remove the transmission case from the intermediate plate.

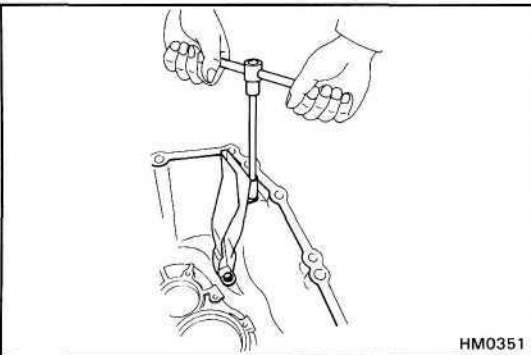

16. REMOVE OIL RECEIVER FROM TRANSMISSION CASE

Remove the two bolts and oil receiver.

17. REMOVE OIL RECEIVER FROM INTERMEDIATE PLATE

Remove the three bolts and oil receiver.

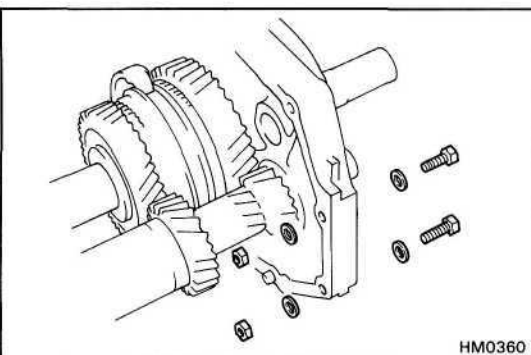

18. MOUNT INTERMEDIATE PLATE IN VISE

- (a) Use two clutch housing bolts, plate washers and suitable nuts as shown.

NOTICE: Install the plate washers in reverse of normal. Increase or decrease plate washers so that the bolt tip and front tip surface of the nut are aligned.

- (b) Mount the intermediate plate in vise.

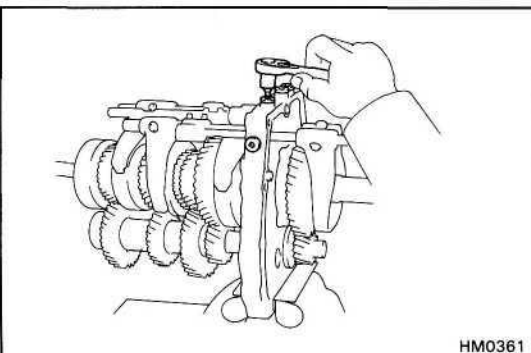

19. REMOVE STRAIGHT SCREW PLUGS, LOCKING BALLS AND SPRINGS

- (a) Using a torx socket wrench, remove the four screw plugs.

(Torx socket wrench T40 09042-00020)

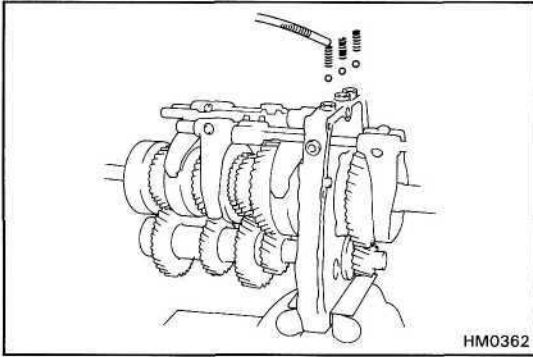

- (b) Using a magnetic finger, remove the springs and balls.
 4-Speed: Three springs and balls

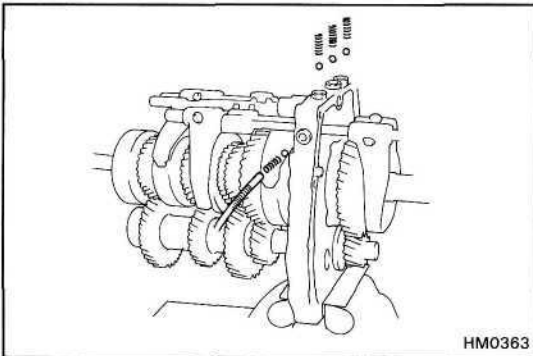

- 5-Speed: Four springs and balls

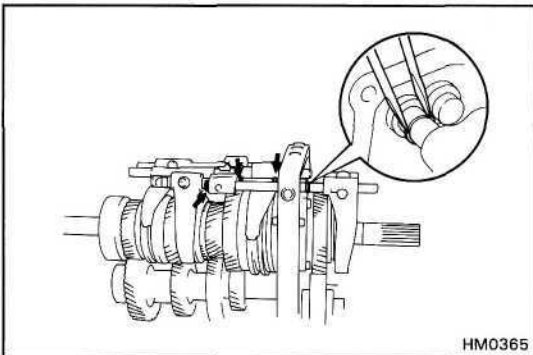

20. REMOVE FORK SHAFT SNAP RINGS

Using two screwdrivers and a hammer, tap out the snap rings.

- 4-Speed: One snap ring
 5-Speed: Four snap rings

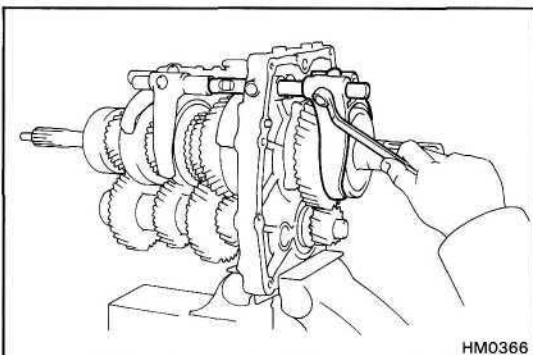

21. REMOVE SHIFT FORK SHAFT NO.3 OR NO.4 AND REVERSE SHIFT FORK

- 4-Speed: Shift fork shaft No.3
 5-Speed: Shift fork shaft No.4

- (a) Remove the set bolt.

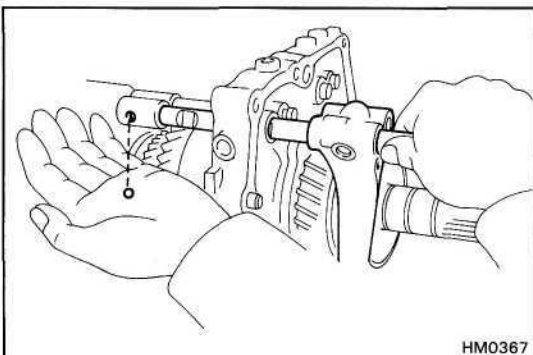

- (b) (5-Speed)
 Remove the shift fork shaft No.4, reverse shift fork and ball.
 (c) (4-Speed)
 Remove the shift fork shaft No.3 and reverse shift fork.

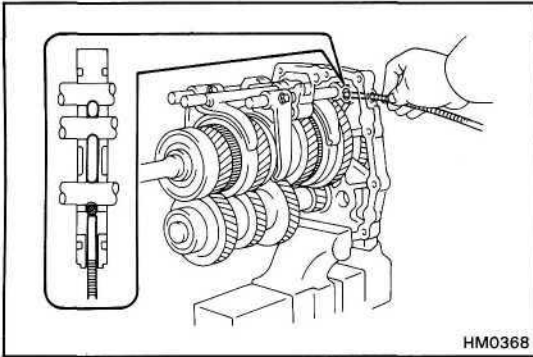
**22. (5-Speed)****REMOVE SHIFT FORK SHAFT NO.3. SHIFT FORK NO.3 AND REVERSE SHIFT HEAD**

(a) Using a magnetic finger, remove the interlock ball.

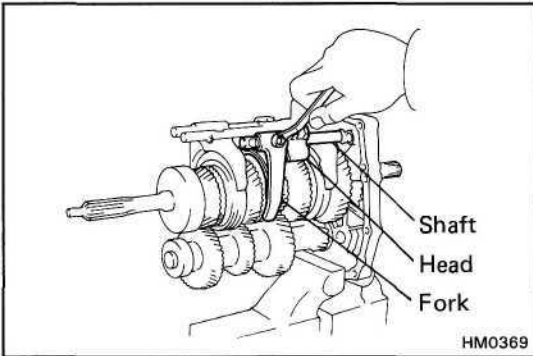

(b) Remove the set bolt.

(c) Remove the shift fork shaft No.3, shift fork No.3 and reverse shift head.

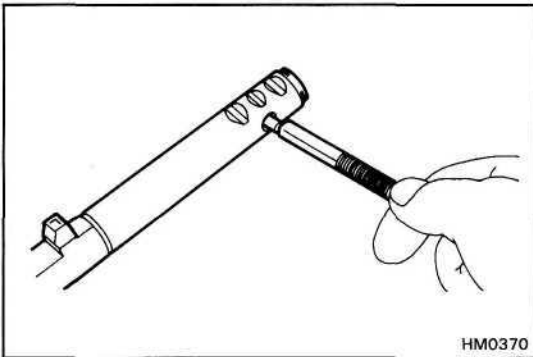

(d) Using a magnetic finger, remove the interlock pin from shift fork shaft No.3.

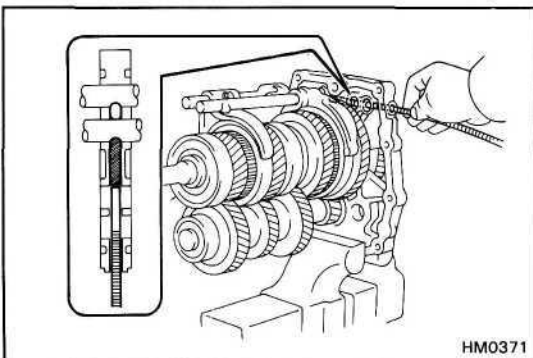
**23. REMOVE SHIFT FORK SHAFT NO.2 AND SHIFT FORK NO.1**

(a) Using a magnetic finger, remove the interlock pin.

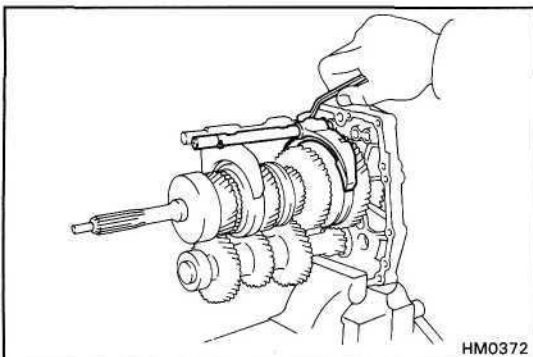

(b) Remove the set bolt.

(c) Remove the shift fork shaft No. 1 and shift fork No. 1.

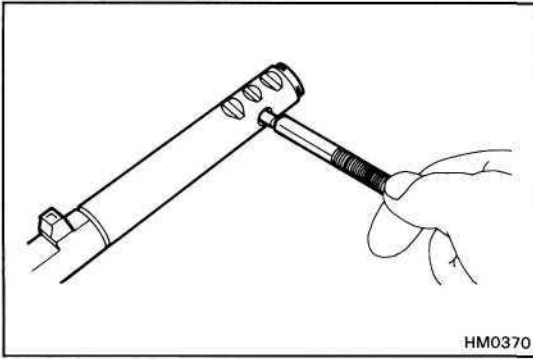

- (d) Using a magnetic finger, remove the interlock pin from shift fork shaft No.1.

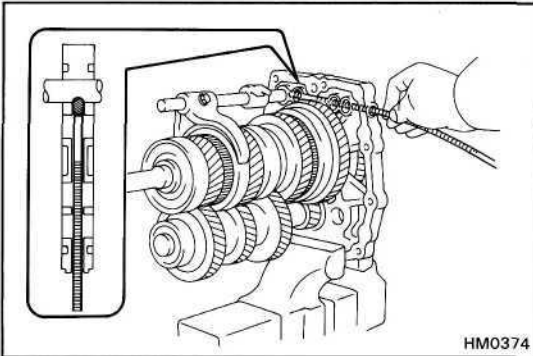

24. REMOVE SHIFT FORK SHAFT NO.2 AND SHIFT FORK NO.2

- (a) Using a magnetic finger, remove the interlock ball.

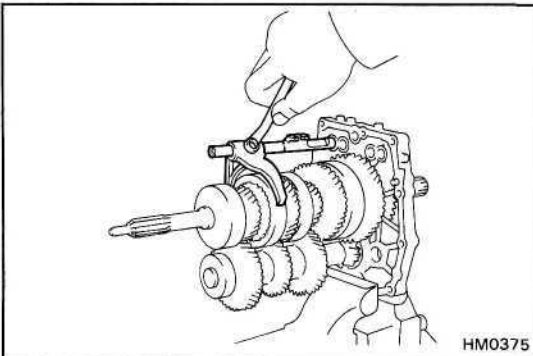

- (b) Remove the set bolt.
- (c) Remove the shift fork shaft No.2 and shift fork No.2.

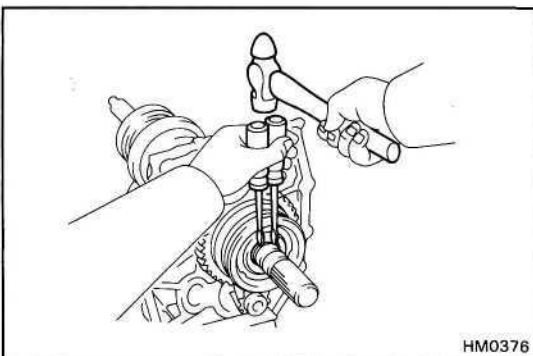

25. REMOVE REVERSE GEAR AND CLUTCH HUB NO.4 ASSEMBLY (w/ SERVICE HOLE)

- (a) Using two screwdrivers and a hammer, drive out the snap ring.

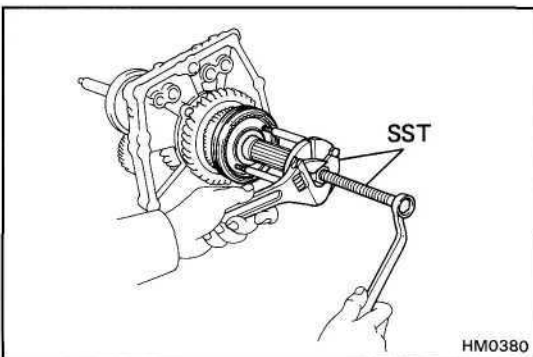

- (b) Using SST and two bolts (90101-08136), remove the clutch hub No.4 assembly.

SST 09310-17010 (09310-07010, 09310-07020)

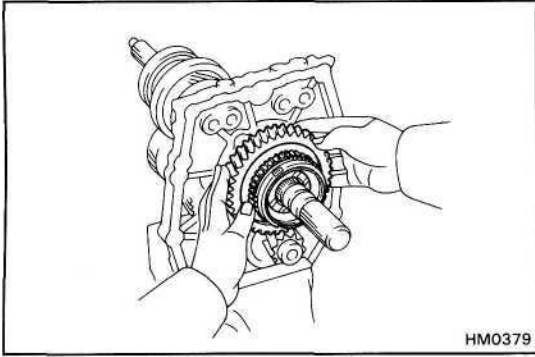

- (c) Remove the synchronizer ring, reverse gear and needle roller bearing.

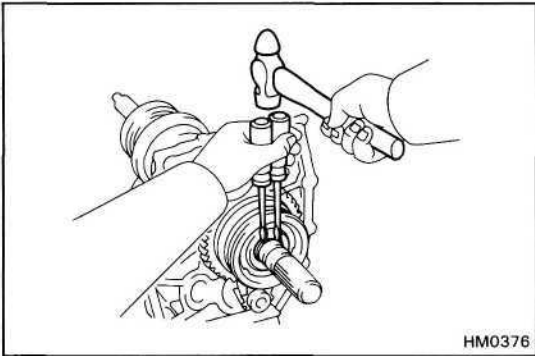

(w/o SERVICE HOLE)

- (a) Using two screwdrivers and a hammer, drive out the snap ring.

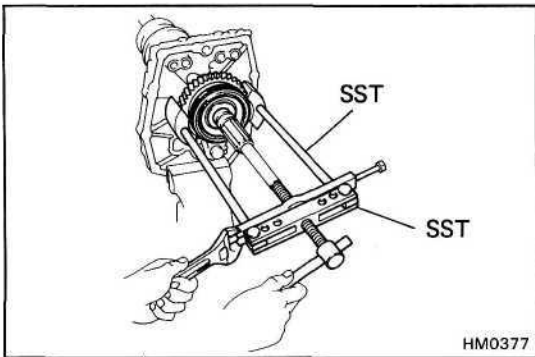

- (b) Using SST, remove the reverse gear with clutch hub No.4 assembly.

SST 09336-60010, 09950-20017

- (c) Remove the needle roller bearing and synchronizer ring.

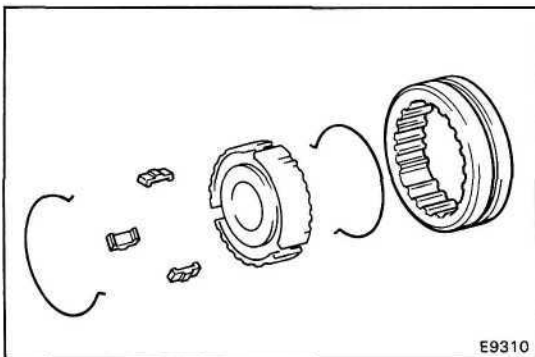

26. REMOVE HUB SLEEVE NO.4, SHIFTING KEYS AND SPRINGS FROM CLUTCH HUB NO.3

Using a screwdriver, remove the two springs and three shifting keys from clutch hub No.4.

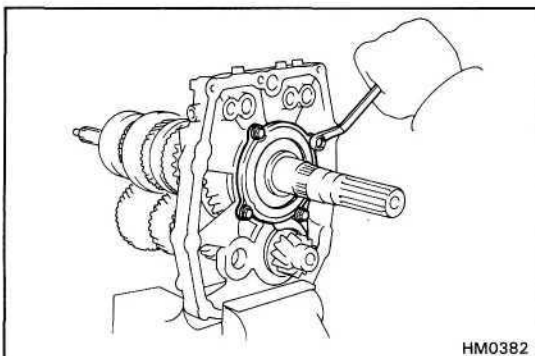

27. REMOVE REAR BEARING RETAINER

Remove the four bolts, and rear bearing retainer.

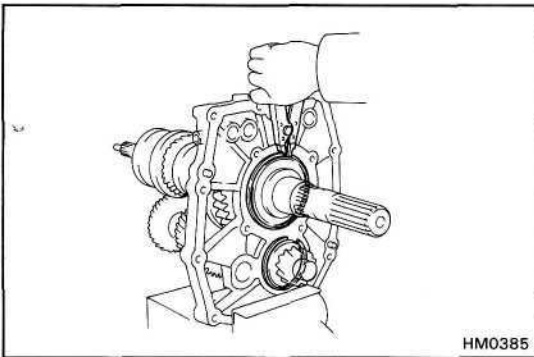

28. REMOVE TWO SNAP RINGS

- (a) Using snap ring pliers, remove the two snap rings.

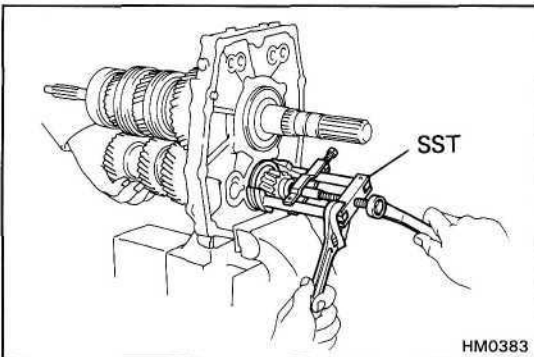

29. REMOVE COUNTER GEAR

- (a) Using SST, remove the rear bearing outer race.
SST 09602-35011

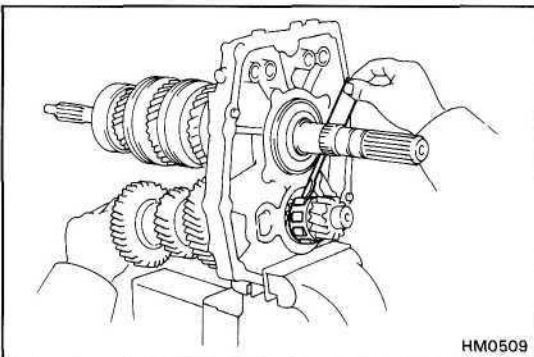

- (b) Using a screwdriver, remove the roller bearing and counter gear.

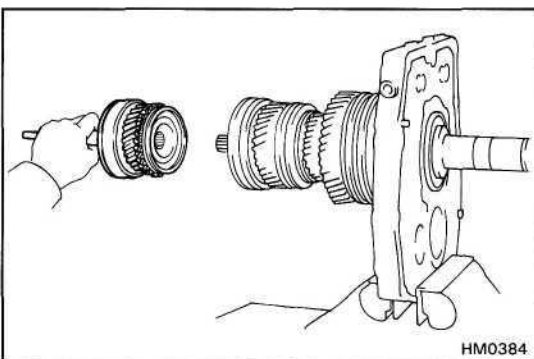

30. REMOVE INPUT SHAFT

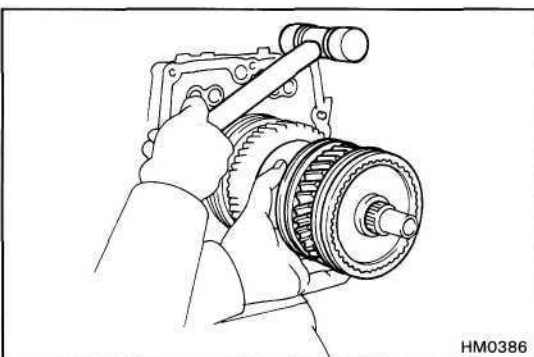

31. REMOVE OUTPUT SHAFT

- Remove the output shaft, from the intermediate plate by pulling on the output shaft and tapping on the intermediate plate with plastic hammer.

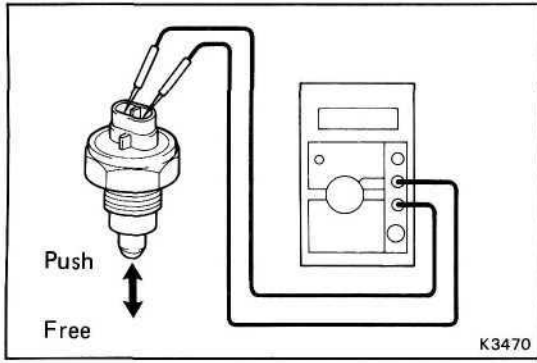

32. INSPECT BACK-UP LIGHT SWITCH

Check that there is continuity between terminals as shown.

| Switch Position | Specified |
|-----------------|---------------|
| Push | Continuity |
| Free | No Continuity |

If operation is not specified replace the switch.

COMPONENT PARTS

Input Shaft Assembly

COMPONENTS

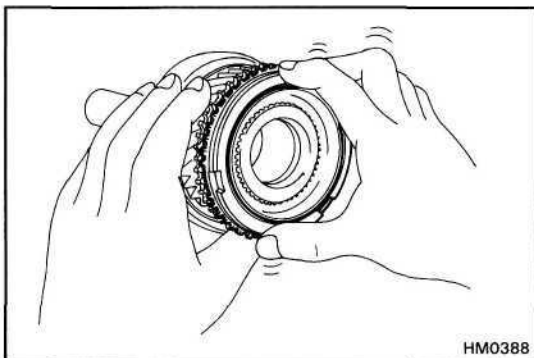
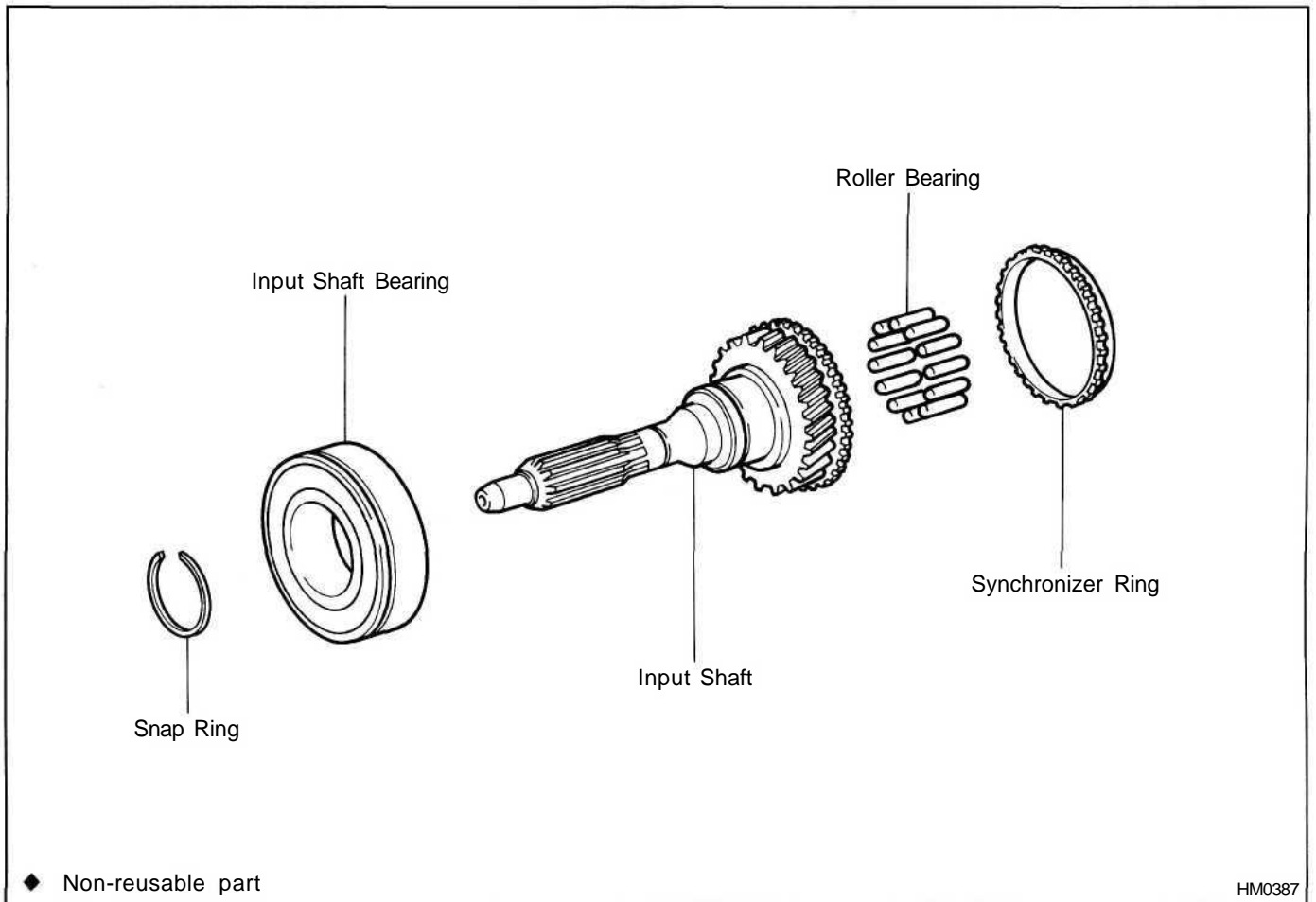

INSPECTION OF INPUT SHAFT ASSEMBLY

INSPECT SYNCHRONIZER RING

(a) Turn the ring and push it into check braking action.

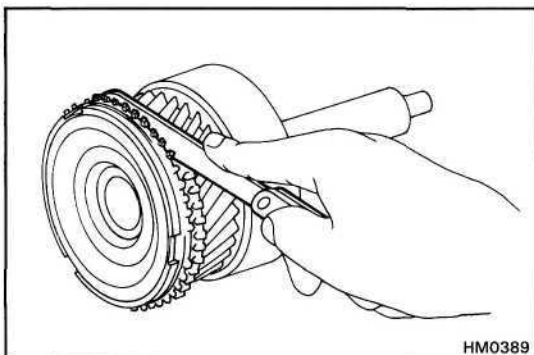

(b) Measure the clearance between the synchronizer ring back and the gear spline end.

Standard clearance:

0.8 - 1.6 mm (0.0315 - 0.0630 in.)

Minimum clearance: 0.6 mm (0.0236 in.)

REPLACEMENT OF BEARING

IF NECESSARY, REPLACE INPUT SHAFT BEARING

(a) Using snap ring pliers, remove the snap ring.

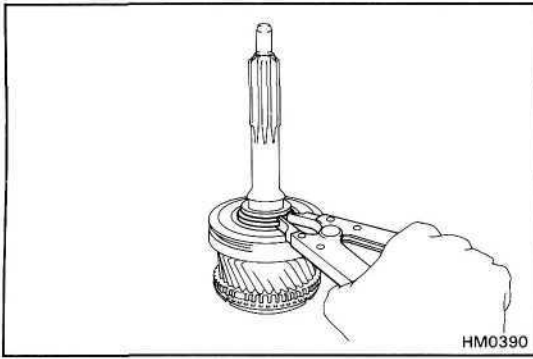

(b) Using a press, remove the bearing.

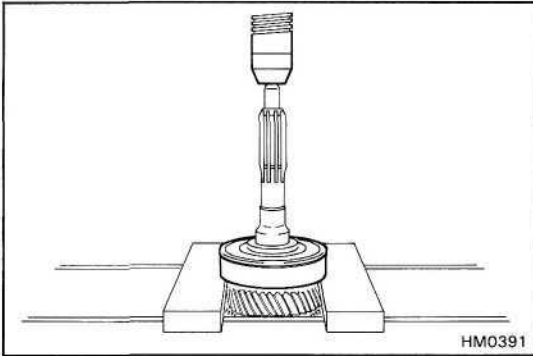

(c) Using SST and a press, install a new bearing.

SST 09316-20011

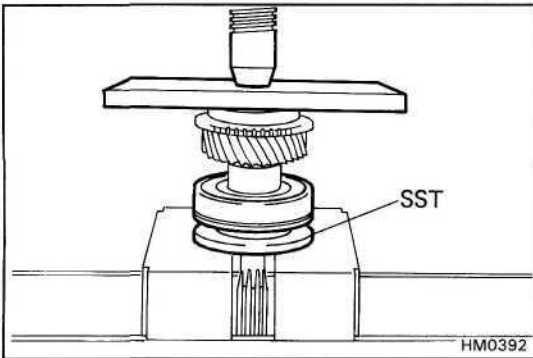

(d) Select a snap ring that will allow minimum axial play.

| Mark | Thickness mm (in.) |
|------|-------------------------------|
| A | 2.50 - 2.55 (0.0984 - 0.1004) |
| B | 2.55 - 2.60 (0.1004 - 0.1024) |
| C | 2.60 - 2.65 (0.1024 - 0.1043) |
| D | 2.65 - 2.70 (0.1043 - 0.1063) |
| E | 2.70 - 2.75 (0.1063 - 0.1083) |
| F | 2.75 - 2.80 (0.1083 - 0.1102) |

(e) Using snap ring pliers, install the snap ring.

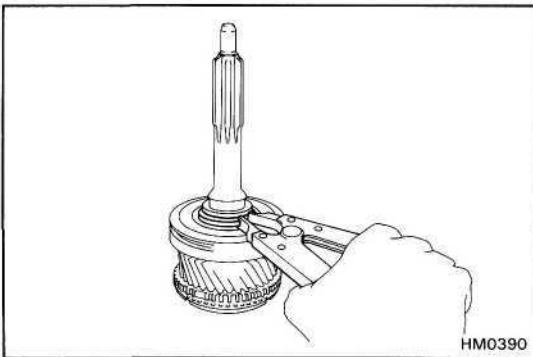

Output Shaft Assembly

COMPONENTS

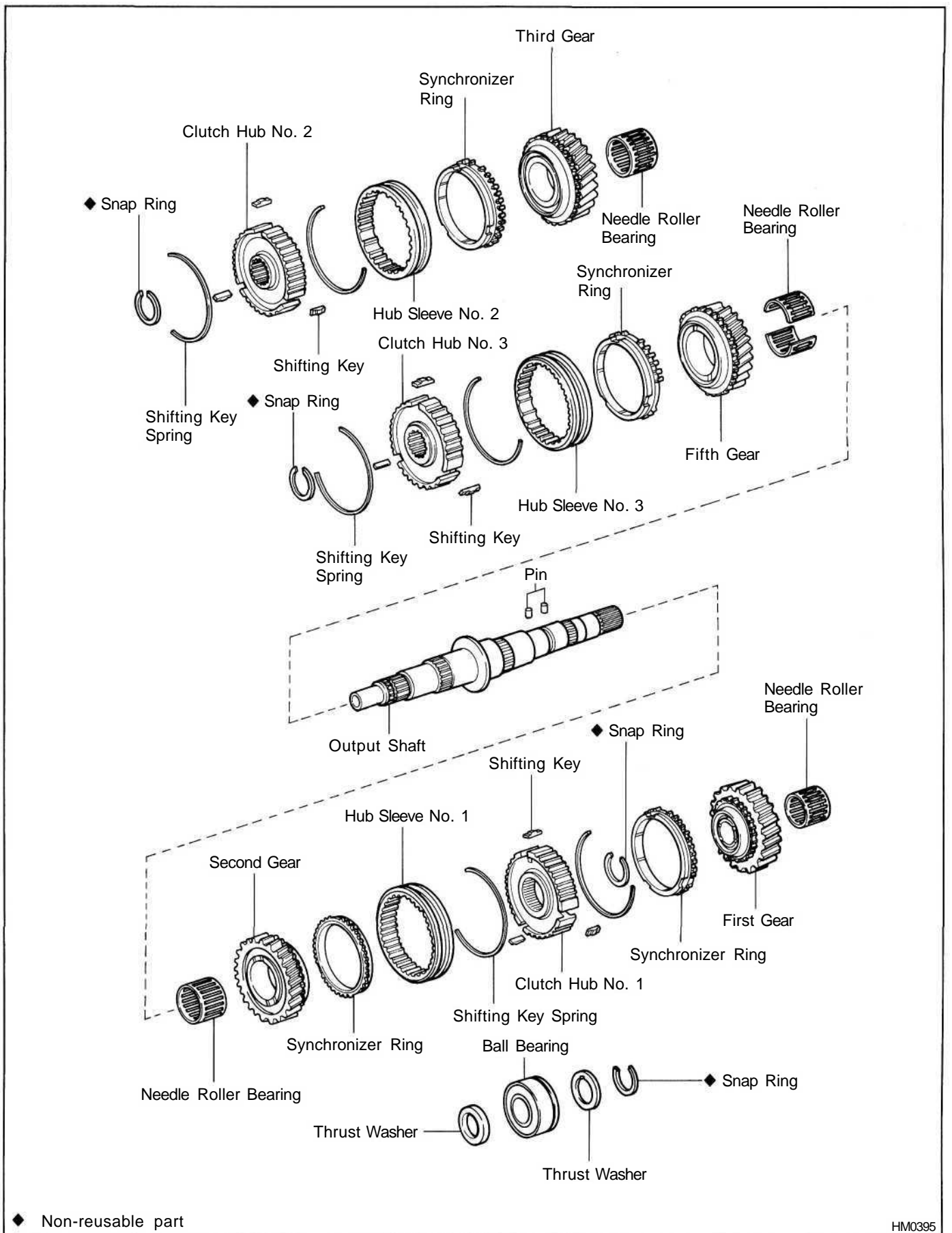

DISASSEMBLY OF OUTPUT SHAFT ASSEMBLY**1. (H140F, H150F)****REMOVE BALL BEARING AND FIRST GEAR**

- (a) Using two screwdrivers and a hammer, drive out the snap ring.

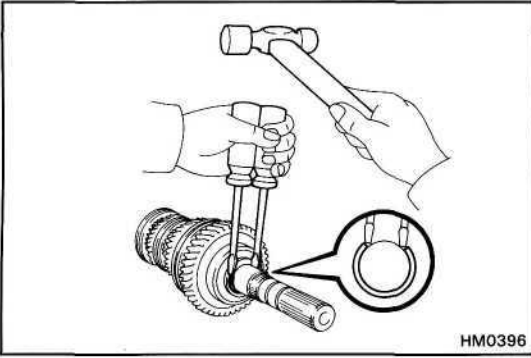

- (b) Remove the thrust washer and pin.

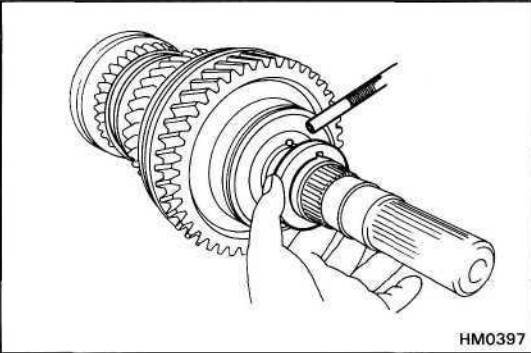

- (c) Using SST, remove the ball bearing.
SST 09950-20017

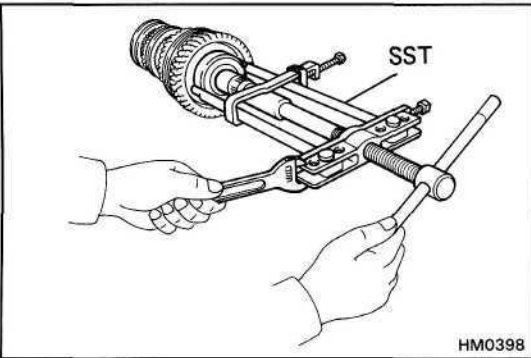

- (d) Remove the thrust washer and pin.

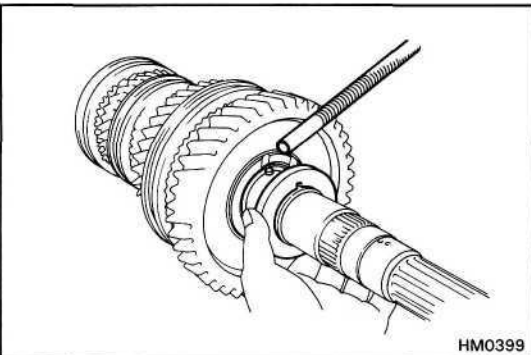

- (e) Remove the first gear, synchronizer ring No.1 and needle roller bearing.

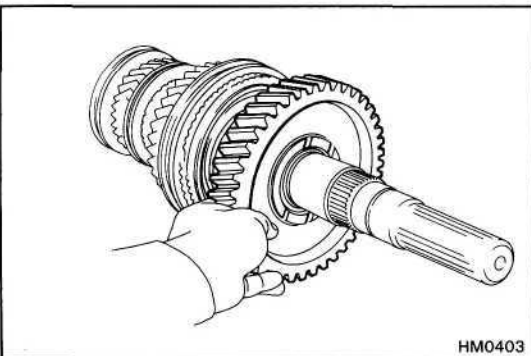

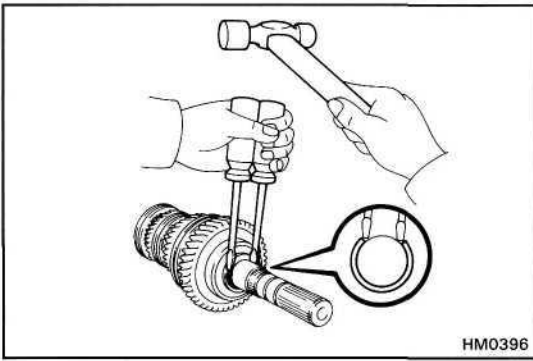

(H151F)
REMOVE BALL BEARING AND FIRST GEAR

- (a) Using two screwdrivers and a hammer, drive out the snap ring.

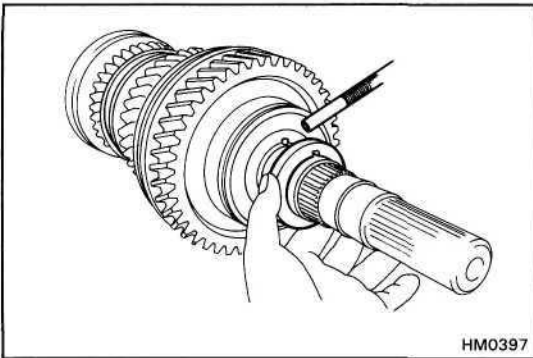

- (b) Remove the thrust washer and pin.

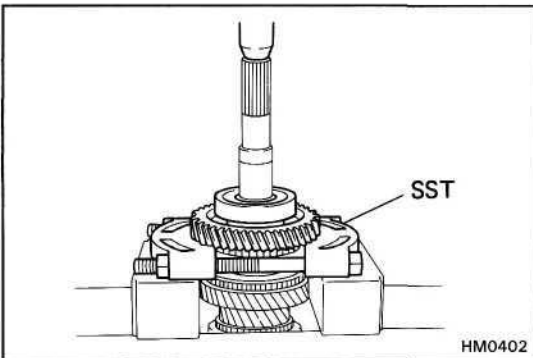

- (c) Using SST and a press, remove the ball bearing, thrust washer and first gear.

SST 09555-55010

- (d) Remove the pin and needle roller bearing.

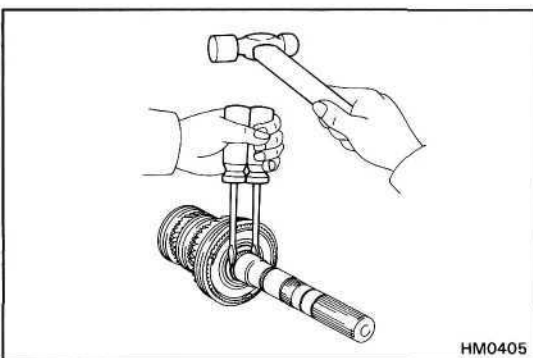

2. REMOVE HUB SLEEVE NO. 1 ASSEMBLY, SYNCHRONIZER RING NO. 1, SECOND GEAR AND NEEDLE ROLLER BEARING

- (a) Using two screwdrivers and a hammer, drive out the snap ring.

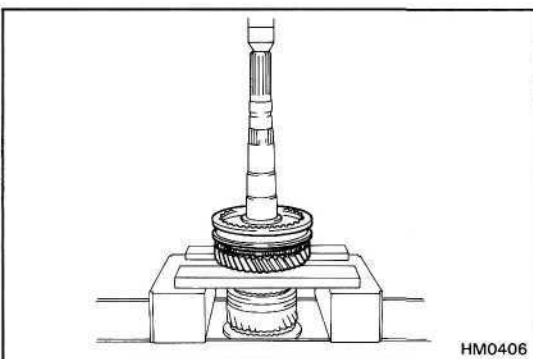

- (b) Using a press, remove the hub sleeve No.1 assembly, synchronizer ring No.1, and second gear.

- (c) Remove the needle roller bearing.

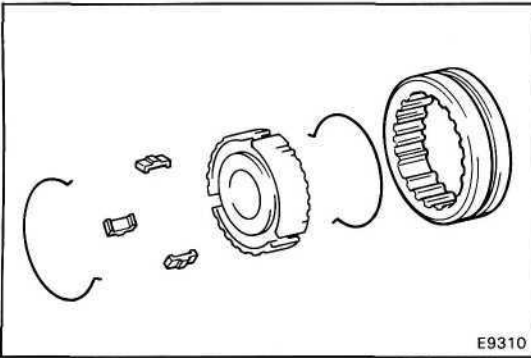

3. REMOVE HUB SLEEVE NO.1, SHIFTING KEYS AND SPRINGS FROM CLUTCH HUB NO.1

Using a screwdriver, remove the three shifting keys and two springs from the clutch hub No.1.

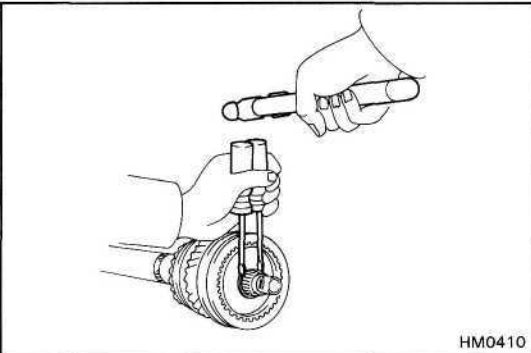

4. REMOVE HUB SLEEVE NO.2 ASSEMBLY, SYNCHRONIZER RING, THIRD GEAR AND NEEDLE ROLLER BEARING

(a) Remove two screwdrivers and a hammer, drive out the snap ring.

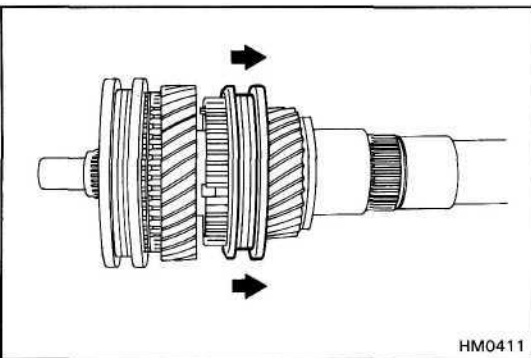

(b) (H150F,H151F)
Shift hub sleeve No.3 onto the fifth gear.

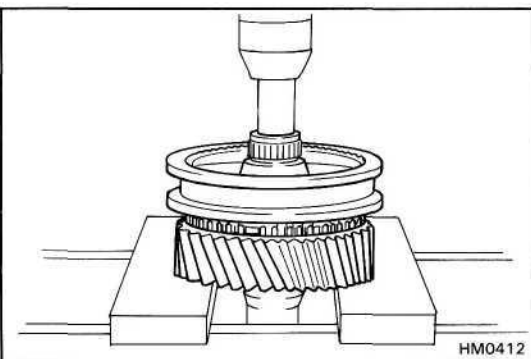

(c) (H140F)
Using a press, remove the hub sleeve No.2 assembly, synchronizer ring and third gear.

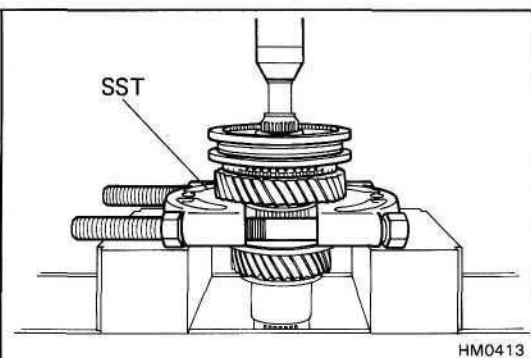

(H150F,H151F)
Using SST and a press, remove the hub sleeve No.2 assembly, synchronizer ring and third gear.

SST 09555-55010

(d) Remove the needle roller bearing.

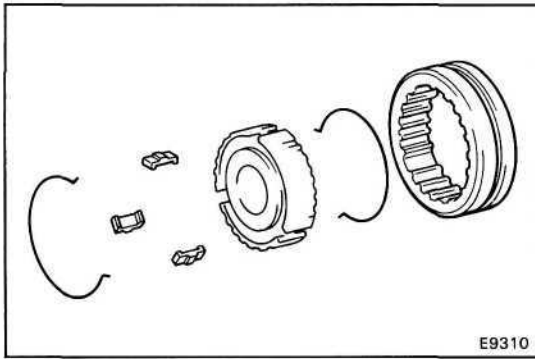

5. **(H150F,H151F)**
REMOVE HUB SLEEVE NO.2, SHIFTING KEYS AND SPRINGS FROM CLUTCH HUB NO.2

Using a screwdriver, remove the three shifting keys and two springs from the clutch hub No.2.

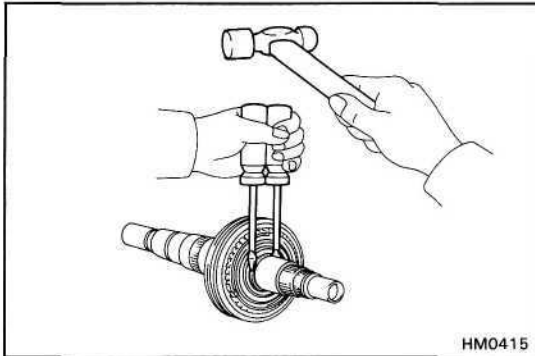

6. **(H150F.H151F)**
REMOVE HUB SLEEVE NO.3 ASSEMBLY, SYNCHRONIZER RING, FIFTH GEAR AND NEEDLE ROLLER BEARING

(a) Using two screwdriver, and a hammer, drive out the snap ring.

(b) Using SST and a press, remove the hub sleeve No.3 assembly, synchronizer ring.

SST 09950-00020

(c) Remove the needle roller bearing.

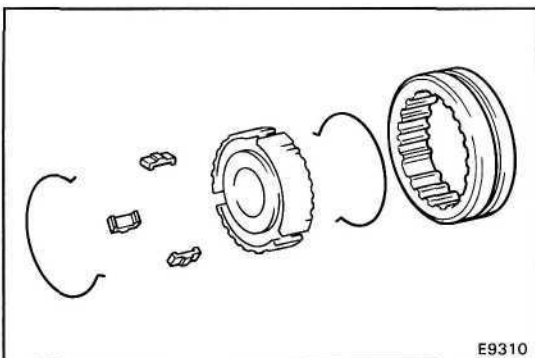
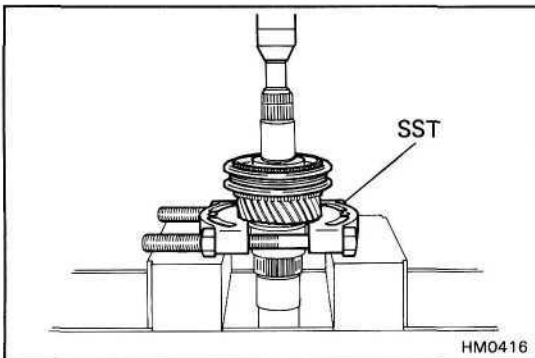

7. **(H150F,H151F)**
REMOVE HUB SLEEVE NO.3 SHIFTING KEYS AND SPRINGS FROM CLUTCH HUB NO.3

Using a screwdriver, remove the three shifting keys and two springs from the clutch hub No.3.

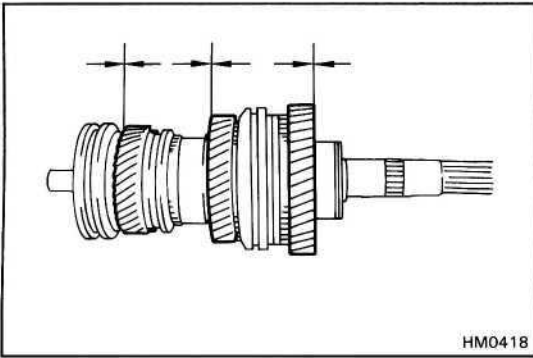

HM0418

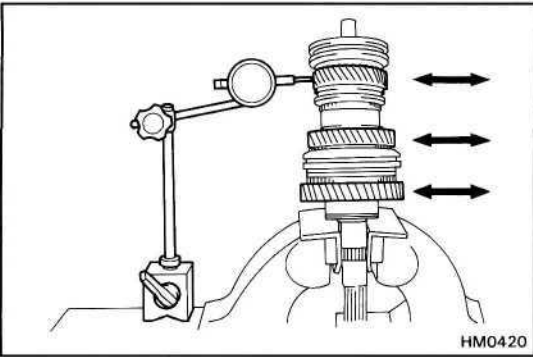

HM0420

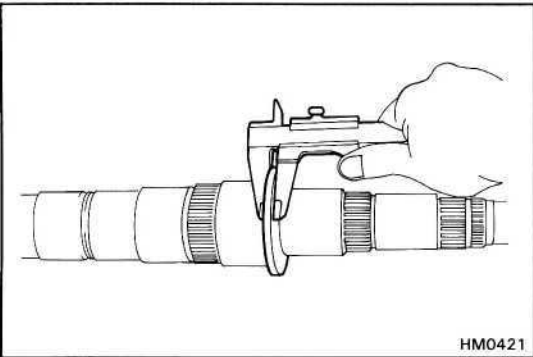

HM0421

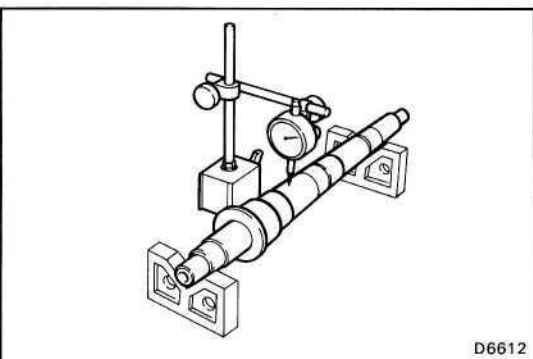

D6612

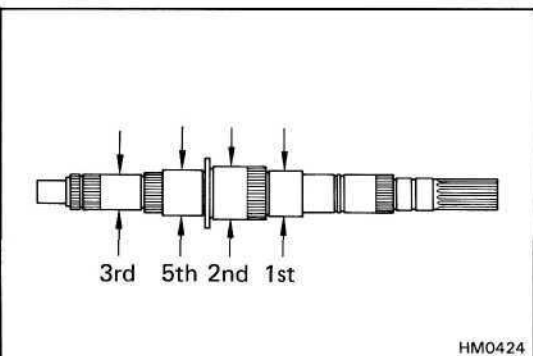

HM0424

INSPECTION OF OUTPUT SHAFT ASSEMBLY

1. MEASURE EACH GEAR THRUST CLEARANCE

Measure the thrust clearance of each gear.

Standard clearance:

1st and 3rd gear 0.1 — 0.45 mm
(0.0039 - 0.0177 in.)

2nd and 5th gear 0.1 — 0.35 mm
(0.0039 - 0.0138 in.)

Maximum clearance:

1st and 3rd gear 0.45 mm (0.0177 in.)

2nd and 5th gear 0.35 mm (0.0138 in.)

2. MEASURE EACH GEAR OIL CLEARANCE

Using a dial indicator, measure the oil clearance of each gear.

Standard clearance:

1st and 3rd gear 0.020 — 0.073 mm
(0.0008 - 0.0029 in.)

2nd and 5th gear 0.015 - 0.068 mm
(0.0006 - 0.0027 in.)

Maximum clearance:

1st and 3rd gear 0.073 mm (0.0029 in.)

2nd and 5th gear 0.068 mm (0.0027 in.)

3. (H150F,H151F) INSPECT OUTPUT SHAFT

(a) Using calipers, measure the output shaft flange thickness.

Minimum thickness: 4.725 mm (0.1860 in.)

(b) Using a dial indicator, check the shaft runout.

Maximum runout: 0.05 mm (0.0020 in.)

(c) Using a micrometer, measure the outer diameter of the output shaft journal.

Minimum diameter:

1st 49.979 mm (1.9677 in.)

2nd 57.984 mm (2.2828 in.)

3rd 37.979 mm (1.4952 in.)

5th 45.984 mm (1.8104 in.)

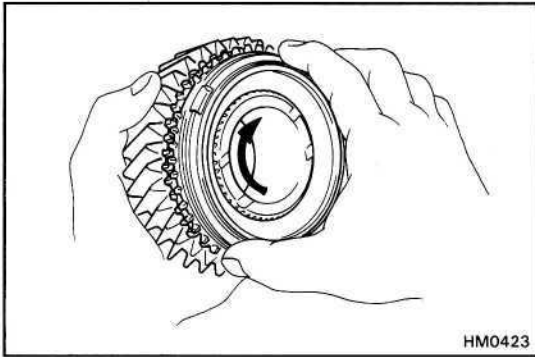

4. INSPECT SYNCHRONIZER RINGS

(a) Turn the ring and push it in to check the braking action.

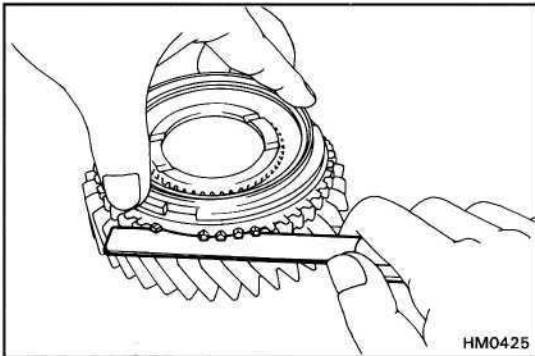

(b) Measure the clearance between the synchronizer ring back and the gear spline end.

(H140F, H150F)

Standard clearance:

| | |
|----------------------|-------------------------------------|
| 1st and 2nd gear | 1.1 — 1.9 mm (0.043 - 0.075 in.) |
| 3rd and reverse gear | 0.8 — 1.6 mm (0.031 - 0.063 in.) |

Minimum clearance:

| | |
|----------------------|--------------------|
| 1st and 2nd gear | 1.1 mm (0.043 in.) |
| 3rd and reverse gear | 0.8 mm (0.031 in.) |

(H151F)

Standard clearance:

| | |
|------------------|--|
| 1st and 2nd gear | 0.85 — 1.4 mm (0.0335 - 0.0551 in.) |
| 3rd gear | 0.75 — 1.3 mm (0.0295 - 0.0512 in.) |

Minimum clearance:

| | |
|------------------|----------------------|
| 1st and 2nd gear | 0.85 mm (0.0335 in.) |
| 3rd gear | 0.75 mm (0.0295 in.) |

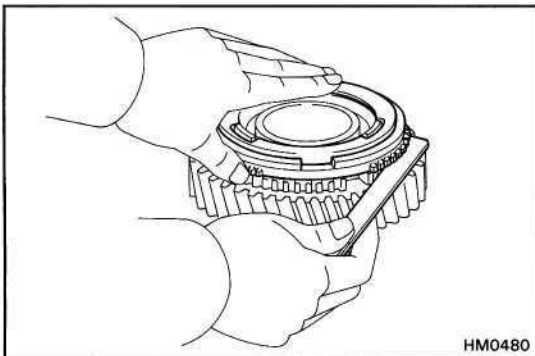

5. MEASURE CLEARANCE OF SHIFT FORKS AND HUB SLEEVES

Using a feeler gauge, measure the clearance between the hub sleeve and shift fork.

Maximum clearance: 0.35 mm (0.0138 in.)

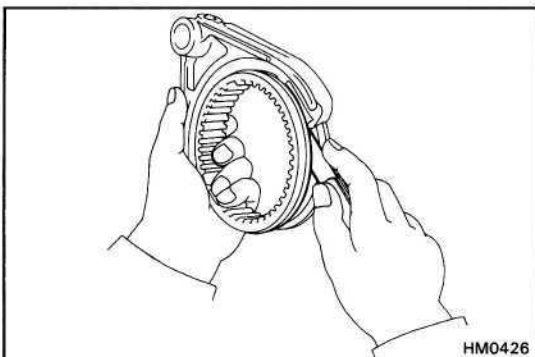

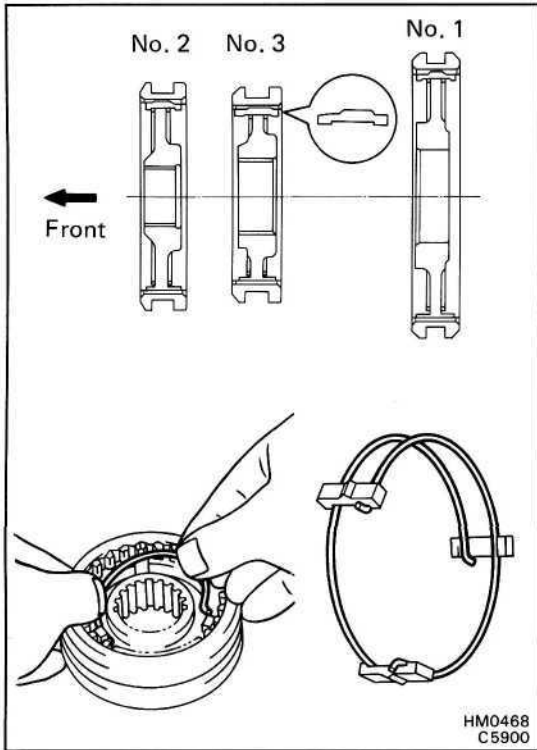

ASSEMBLY OF OUTPUT SHAFT ASSEMBLY

1. INSERT CLUTCH HUB NO. 1, NO.2 AND NO.3 INTO HUB SLEEVE

(a) Install the clutch hub and shifting keys to the hub sleeve.

(b) Install the springs under the shifting keys.

NOTICE: Install the key springs positioned so that their end gaps are not in line.

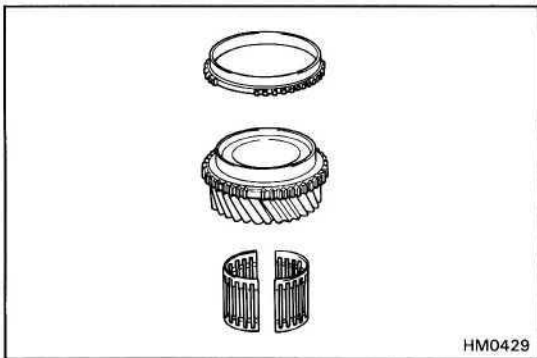

2. INSTALL FIFTH GEAR AND HUB SLEEVE NO.3 ASSEMBLY ON OUTPUT SHAFT

(a) Apply gear oil to the shaft and needle roller bearing.

(b) Place the synchronizer ring on the gear and align the ring slots with the shifting keys.

(c) Install the needle roller bearing in the fifth gear.

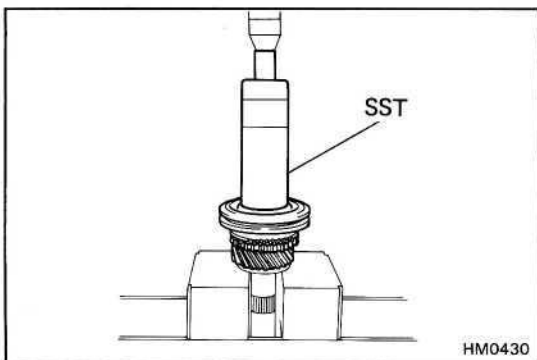

(d) Using SST and a press, install the fifth gear and hub sleeve No.3.

SST 09316-60010 (09316-00010)

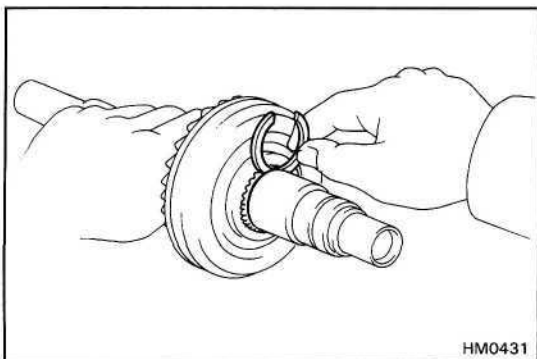

3. INSTALL SNAP RING

(a) Select a snap ring that will allow minimum axial play.

| Mark | Thickness mm (in.) |
|------|-------------------------------|
| A | 2.40 – 2.45 (0.0945 – 0.0965) |
| B | 2.45 – 2.50 (0.0965 – 0.0984) |
| C | 2.50 – 2.55 (0.0984 – 0.1004) |
| D | 2.55 – 2.60 (0.1004 – 0.1024) |
| E | 2.60 – 2.65 (0.1024 – 0.1044) |
| F | 2.65 – 2.70 (0.1044 – 0.1063) |

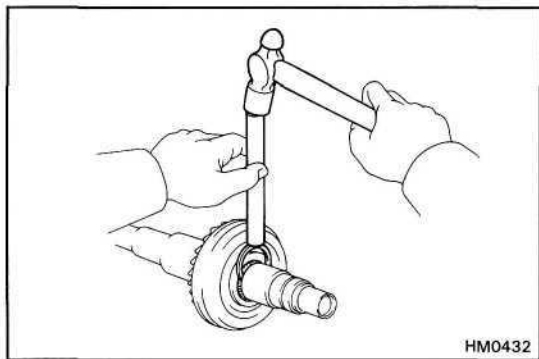

(b) Using a brass bar and hammer, drive in the snap ring.

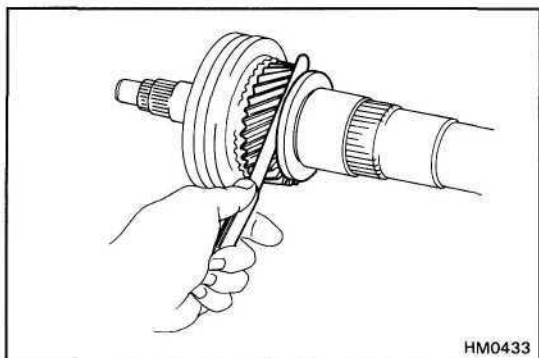

4. MEASURE FIFTH GEAR THRUST CLEARANCE

Using a feeler gauge, measure the fifth gear thrust clearance.

Standard clearance: 0.1 — 0.35 mm
(0.0039 - 0.0138 in.)

Maximum clearance: 0.35 mm (0.0138 in.)

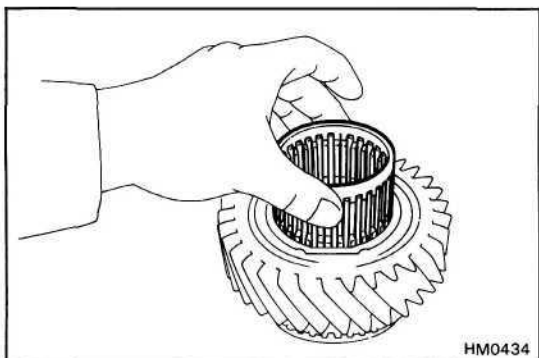

5. INSTALL THIRD GEAR AND HUB SLEEVE NO.2 ASSEMBLY

- (a) Apply gear oil to the shaft and needle roller bearing.
- (b) Place the synchronizer ring on the gear and align the ring slots with the shifting keys.
- (c) Install the needle roller bearing in the third gear.

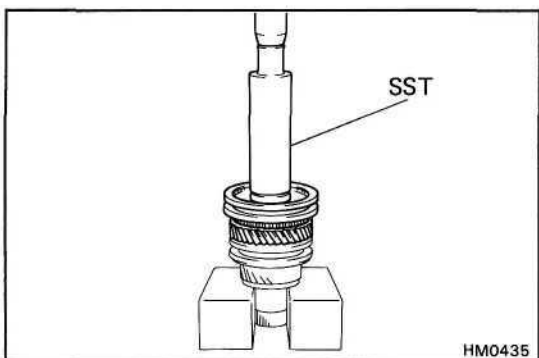

(d) Using SST and a press, install the third gear and hub sleeve No.2.

SST 09316-60010 (09316-00010)

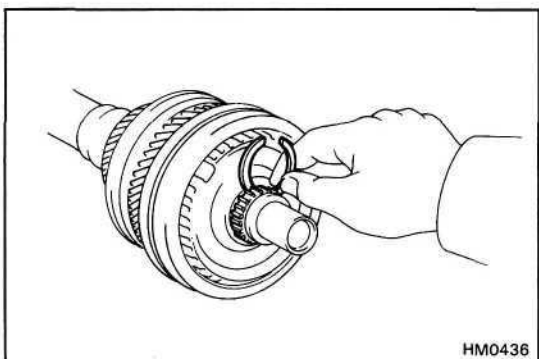

6. INSTALL SNAP RING

(a) Select a snap ring that will allow minimum axial play.

| Mark | Thickness mm (in.) |
|------|-------------------------------|
| 4 | 1.90 - 1.95 (0.0748 - 0.0768) |
| 5 | 1.95 - 2.00 (0.0768 - 0.0787) |
| 6 | 2.00 - 2.05 (0.0787 - 0.0807) |
| 7 | 2.05 - 2.10 (0.0807 - 0.0827) |
| 8 | 2.10 - 2.15 (0.0827 - 0.0847) |
| 9 | 2.15 - 2.20 (0.0847 - 0.0866) |

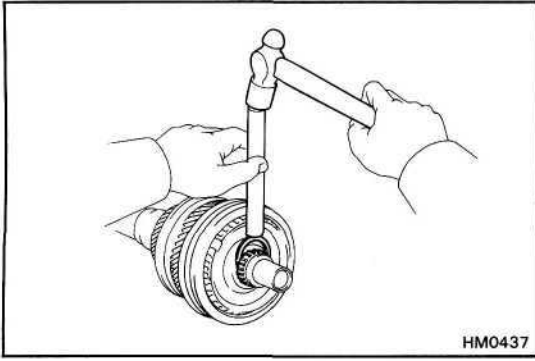

- (b) Using a brass bar and a hammer, drive in a new snap ring.

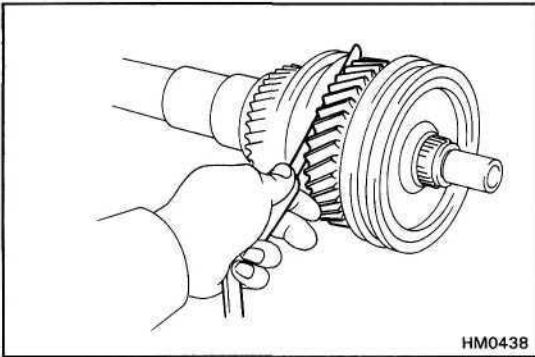

7. MEASURE THIRD GEAR THRUST CLEARANCE

Using a feeler gauge, measure the third gear thrust clearance.

Standard clearance: 0.1 — 0.45 mm
(0.0039 - 0.0138 in.)

Maximum clearance: 0.45 mm (0.0138 in.)

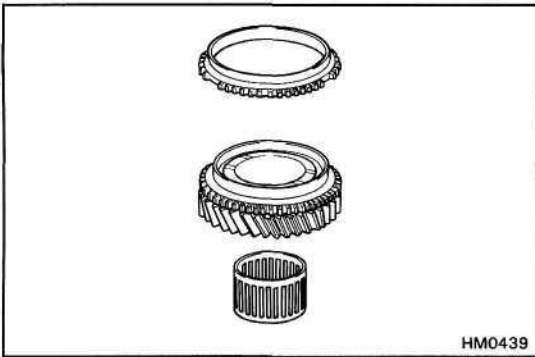

8. INSTALL SECOND GEAR AND HUB SLEEVE NO.1 ASSEMBLY

- (a) Apply gear oil to the shaft and needle roller bearing.
- (b) Place the synchronizer ring on the gear and align the ring slots with the shifting keys.
- (c) Install the needle roller bearing in the second gear.

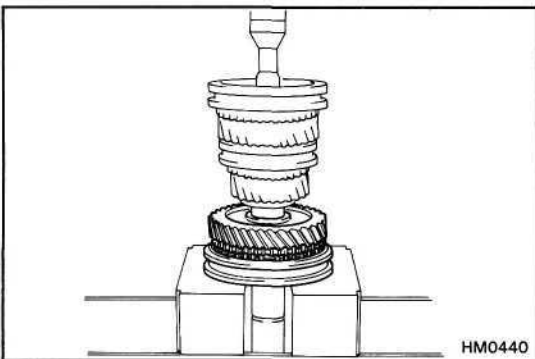

- (d) Using a press, install the second gear and hub sleeve No.1 assembly.

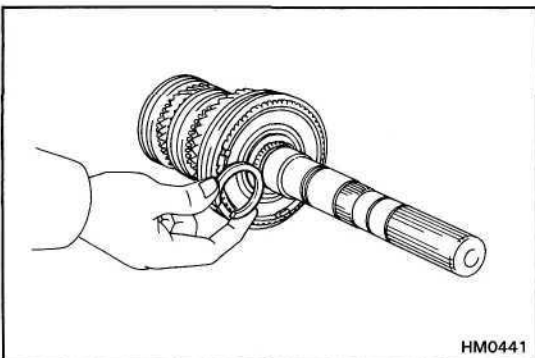

9. INSTALL SNAP RING

- (a) Select a snap ring that will allow minimum axial play.

| Mark | Thickness mm (in.) |
|------|-------------------------------|
| A | 2.90 — 2.95 (0.1142 — 0.1162) |
| B | 2.95 — 3.00 (0.1162 — 0.1181) |
| C | 3.00 — 3.05 (0.1181 — 0.1201) |
| D | 3.05 — 3.10 (0.1201 — 0.1220) |
| E | 3.10 — 3.15 (0.1220 — 0.1240) |
| F | 3.15 — 3.20 (0.1240 — 0.1260) |

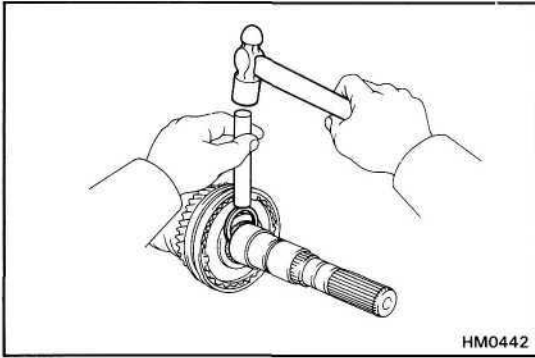

- (b) Using a brass bar and a hammer, drive in a new snap ring.

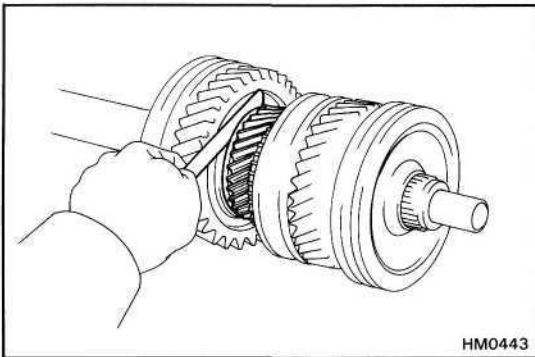

10. MEASURE SECOND GEAR THRUST CLEARANCE

Using a feeler gauge, measure the second gear thrust clearance.

Standard clearance: 0.1 — 0.35 mm
(0.0039 - 0.0138 in.)

Maximum clearance: 0.35 mm (0.0138 in.)

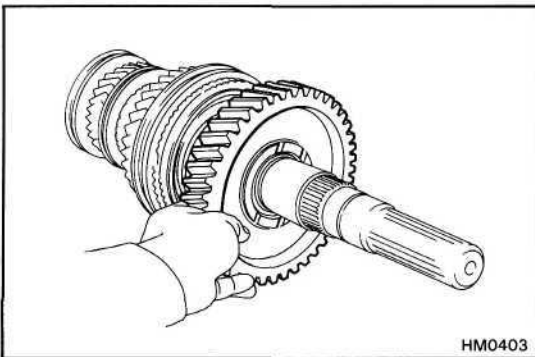

11. INSTALL FIRST GEAR

- (a) Apply gear oil to the shaft and needle roller bearing.
- (b) Place the synchronizer ring on the gear and align the ring slots with the shifting keys.
- (c) Install the needle roller bearing in the first gear.

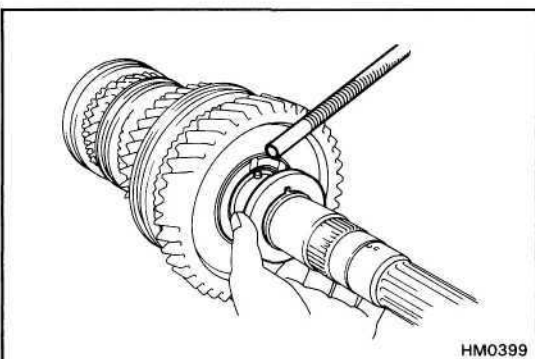

12. INSTALL BALL BEARING

- (a) Install the pin and thrust washer.

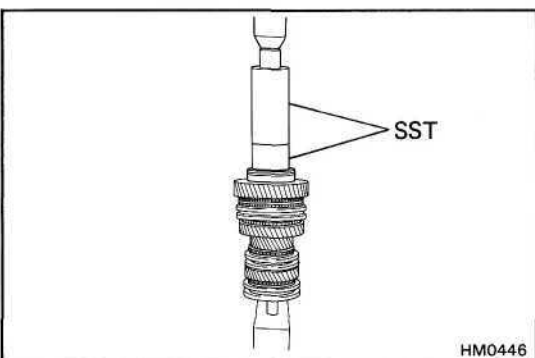

- (b) Using SST and a press, install the ball bearing.
SST 09316-60010 (09316-00010), 09523-36010

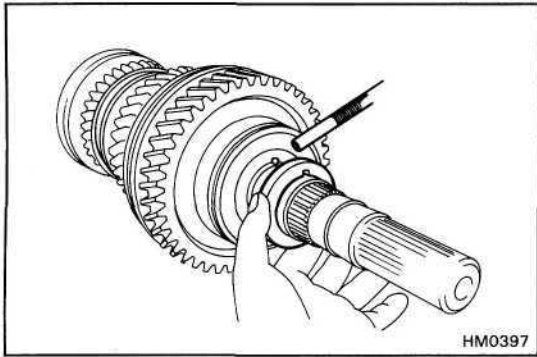

(c) Install the pin and thrust washer.

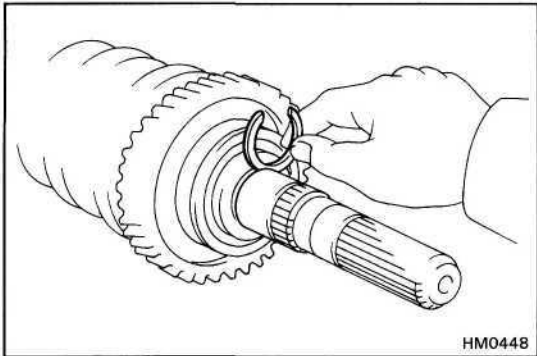

13. INSTALL SNAP RING

(a) Select a snap ring that will allow minimum axial play.

| Mark | Thickness mm (in.) |
|------|-------------------------------|
| A | 2.40 – 2.45 (0.0945 – 0.0965) |
| B | 2.45 – 2.50 (0.0965 – 0.0984) |
| C | 2.50 – 2.55 (0.0984 – 0.1004) |
| D | 2.55 – 2.60 (0.1004 – 0.1024) |
| E | 2.60 – 2.65 (0.1024 – 0.1044) |
| F | 2.65 – 2.70 (0.1044 – 0.1063) |
| G | 2.70 – 2.75 (0.1063 – 0.1083) |
| H | 2.75 – 2.80 (0.1083 – 0.1102) |

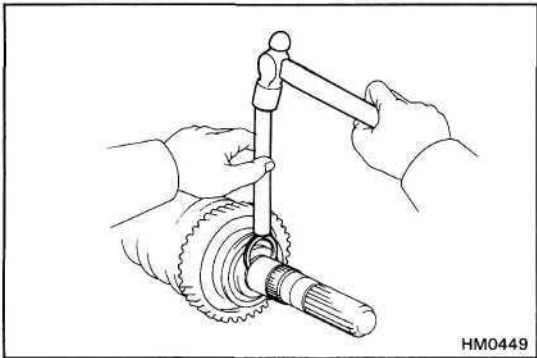

(b) Using a brass bar and a hammer, drive in a new snap ring.

Counter Gear Assembly COMPONENTS

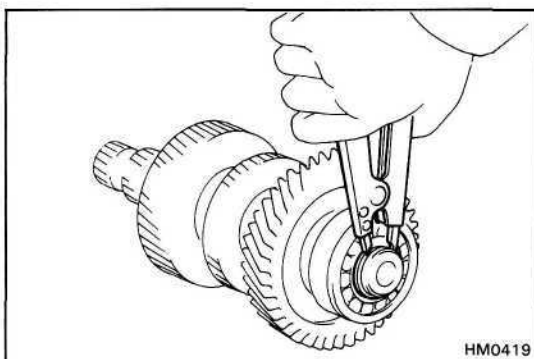
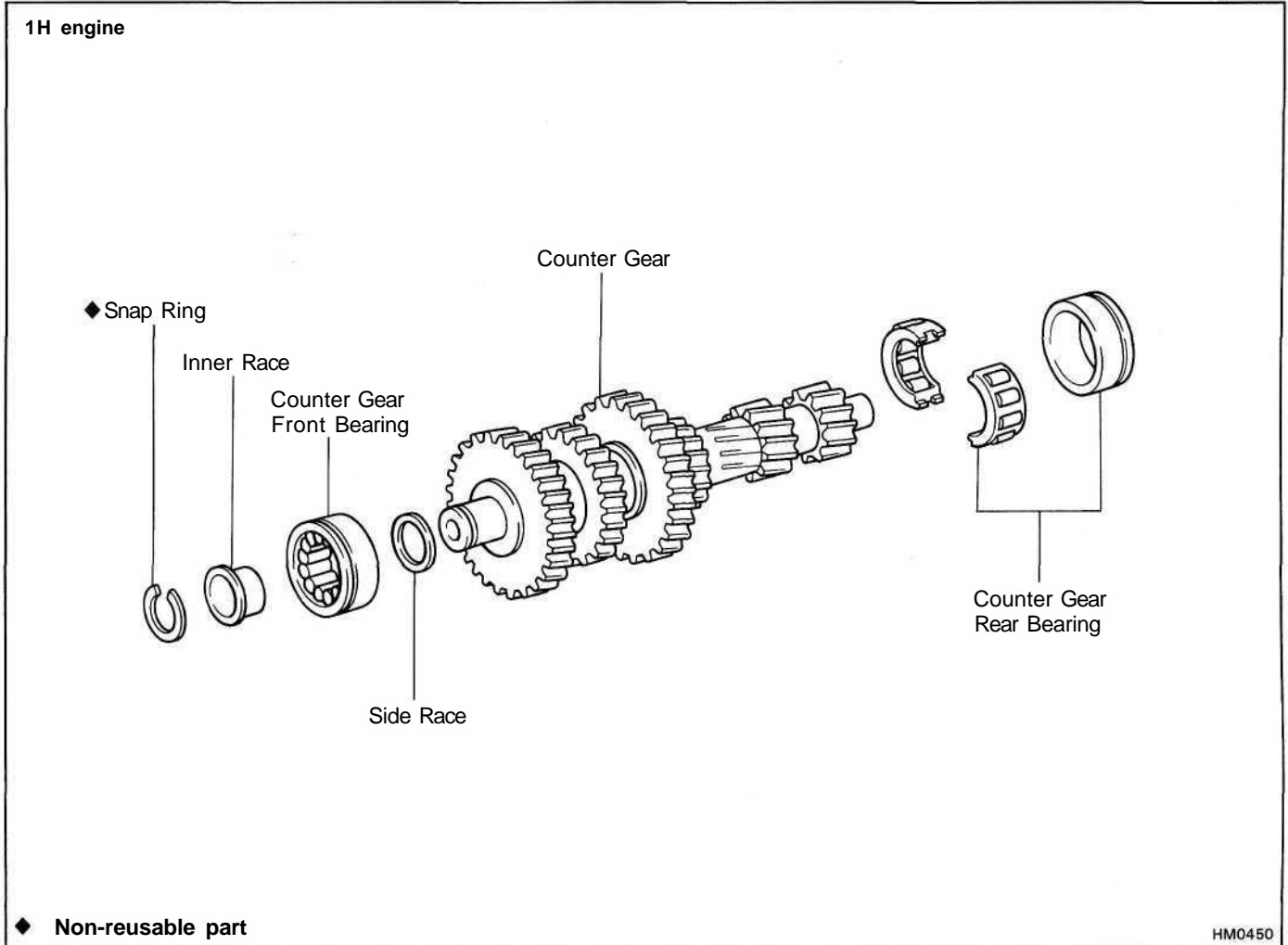

DISASSEMBLY OF COUNTER GEAR ASSEMBLY IF NECESSARY, REPLACE COUNTER GEAR FRONT BEARING AND SIDE RACE

(a) Using snap ring pliers, remove the snap ring.

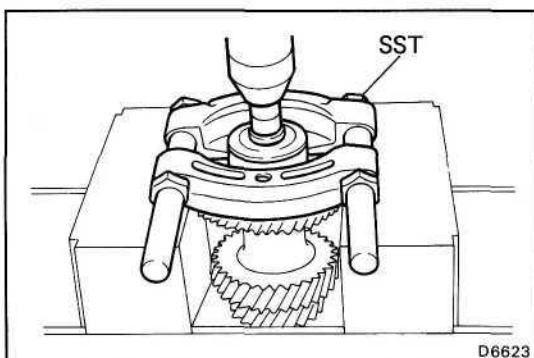

(b) Using SST and socket wrench, press out the bearing.
SST 09950-00020

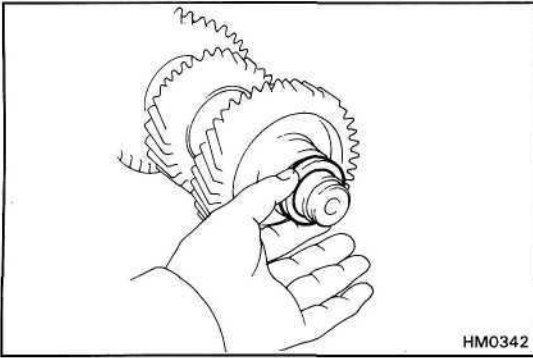

(c) Remove the side race.

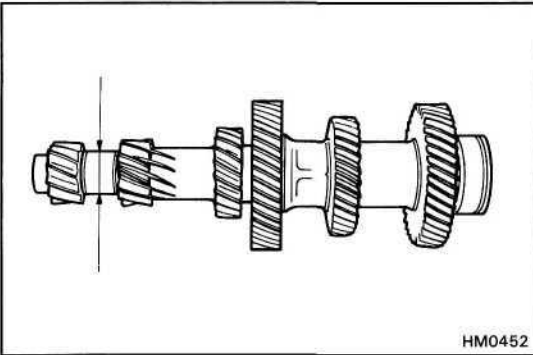

INSPECTION OF COUNTER GEAR ASSEMBLY

INSPECT COUNTER GEAR

Using a micrometer, measure the outer diameter of needle roller bearing race.

Standard diameter: 35.957 — 35.970 mm
(1.4156 - 1.4161 in.)

Maximum diameter: 35.970 mm (1.4161 in.)

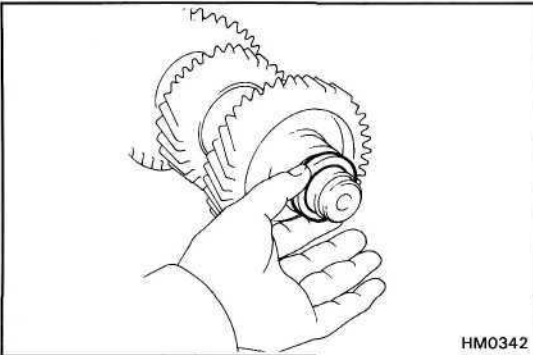

ASSEMBLY OF COUNTER GEAR ASSEMBLY

INSTALL SIDE RACE AND COUNTER GEAR FRONT BEARING

- (a) Apply gear oil to the side race.
- (b) Install the side race.

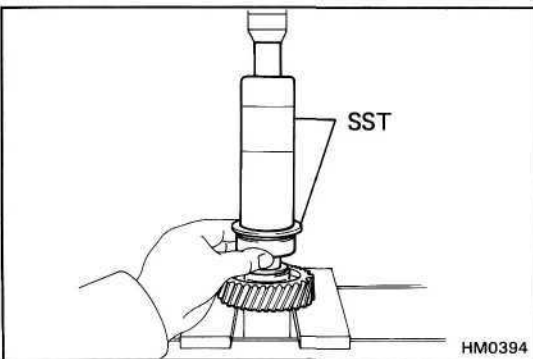

- (c) Apply gear oil to the bearing.
- (d) Using SST and a press, install the bearing.
SST 09316-60010 (09316-00010, 09316-00020)

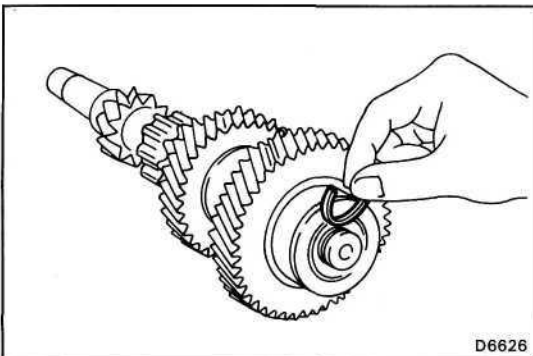

(e) Select a snap ring that will allow minimum axial play.

| Mark | Thickness mm (in.) |
|------|-------------------------------|
| A | 2.45 - 2.50 (0.0970 - 0.0984) |
| B | 2.50 - 2.55 (0.0984 - 0.1004) |
| C | 2.55 - 2.60 (0.1004 - 0.1024) |
| D | 2.60 - 2.65 (0.1024 - 0.1043) |
| E | 2.65 - 2.70 (0.1043 - 0.1063) |
| F | 2.70 - 2.75 (0.1063 - 0.1083) |

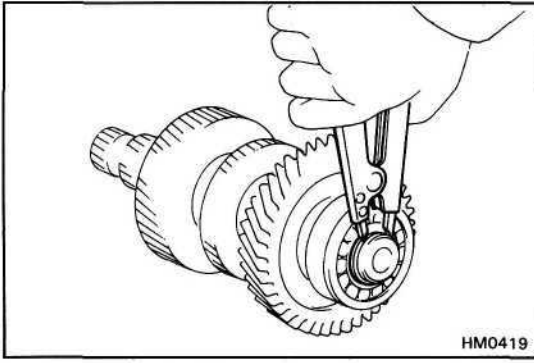

- (f) Using snap ring pliers, install a new snap ring.

Front Bearing Retainer

COMPONENTS

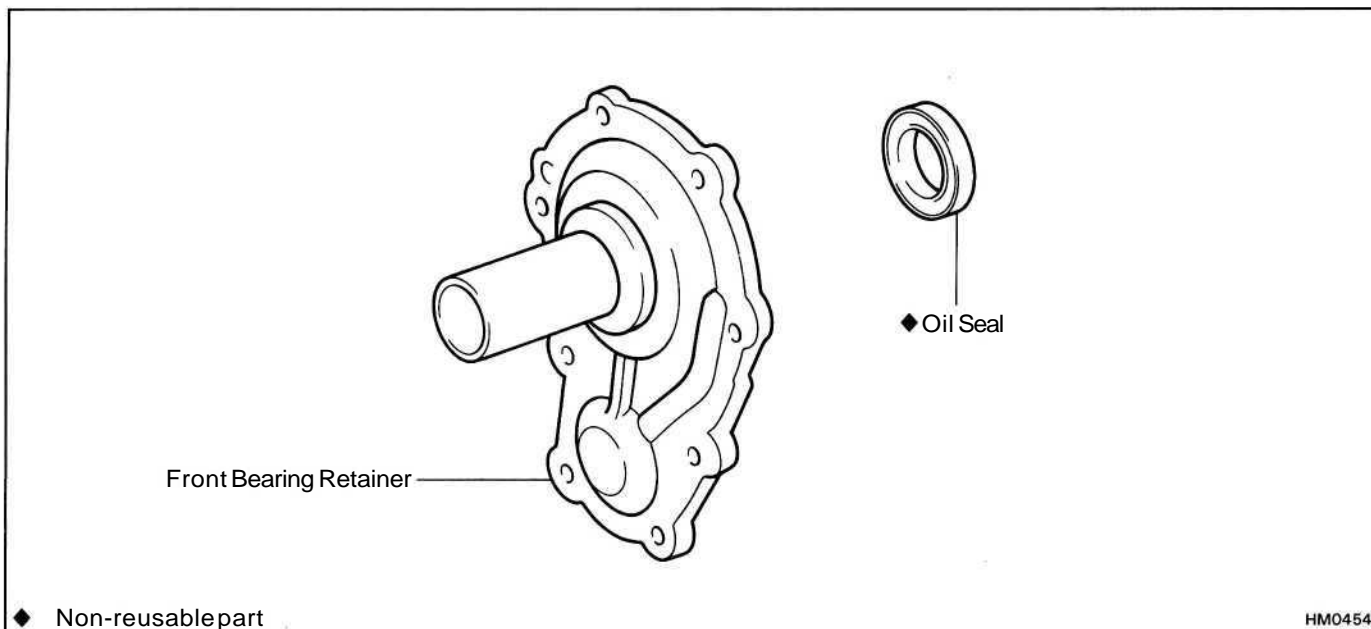

REPLACEMENT OF OIL SEAL

IF NECESSARY REPLACE FRONT BEARING RETAINER OIL SEAL

- (a) Using a screwdriver, pry out the oil seal.

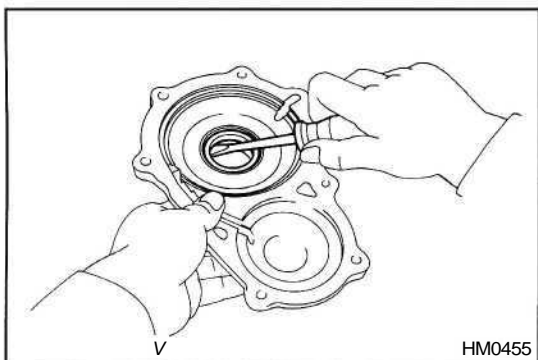

- (b) Using SST and a press in a new oil seal.
 SST 09608-20012 (09608-03020, 09608-00040)
Oil seal depth: 15.4 - 16.2 mm
(0.606 - 0.638 in.)

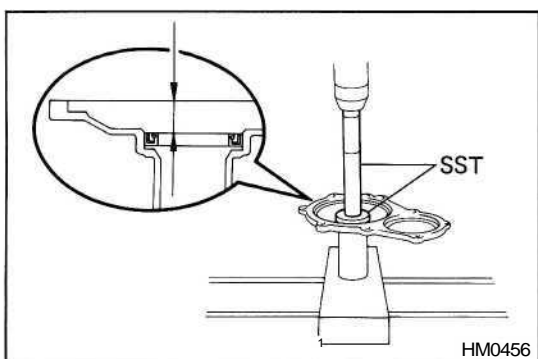

Oil Pump Cover Assembly

COMPONENTS

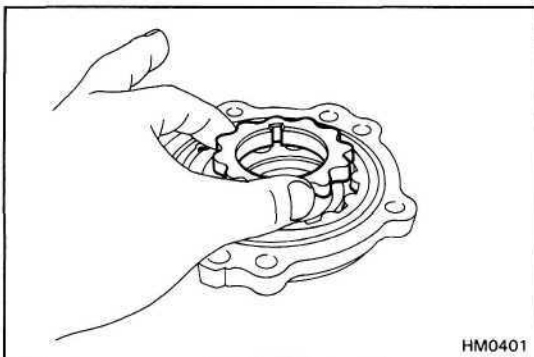
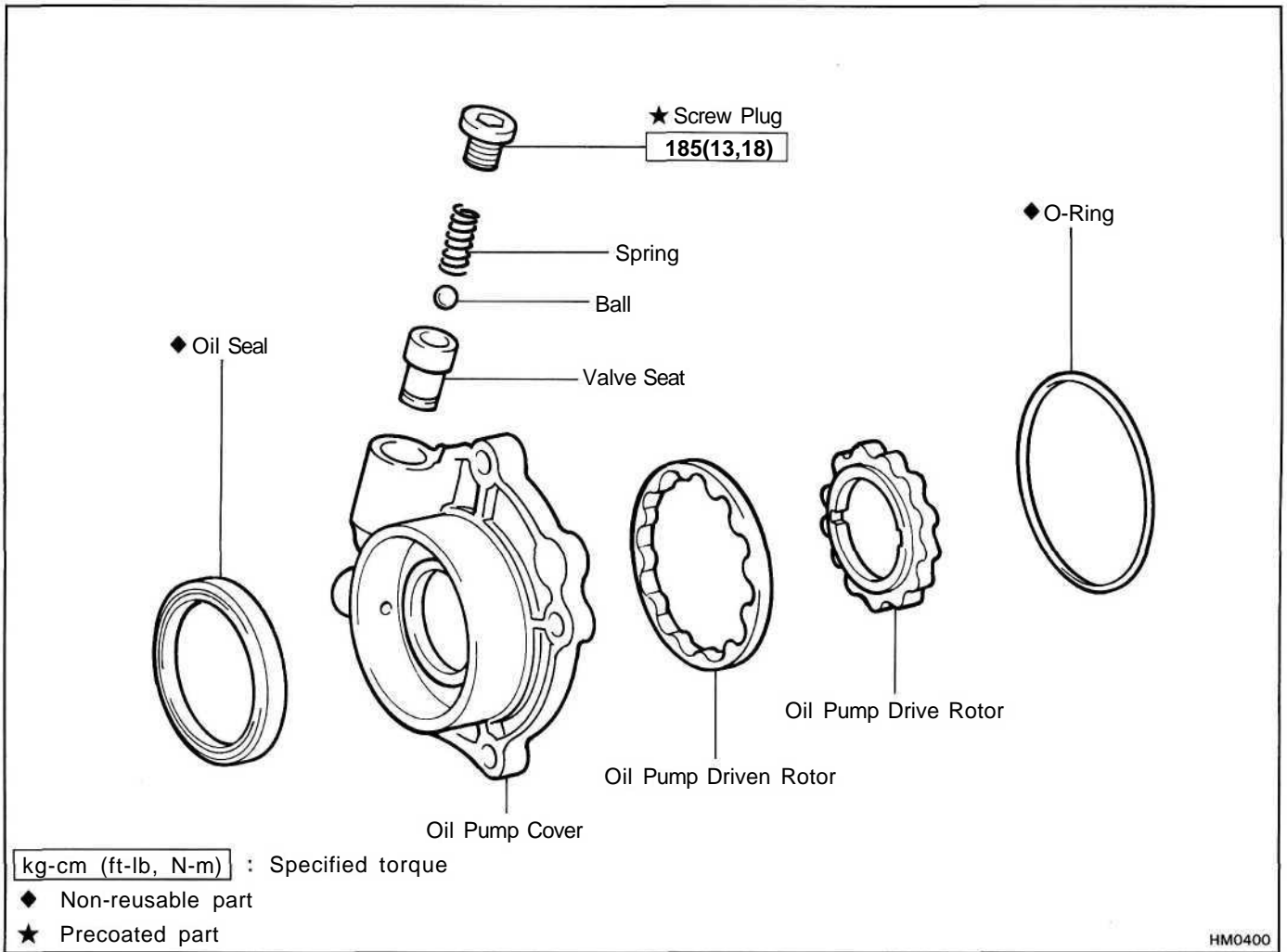

DISASSEMBLY OF OIL PUMP COVER ASSEMBLY

1. REMOVE OIL SEAL
2. REMOVE OIL PUMP DRIVE ROTOR

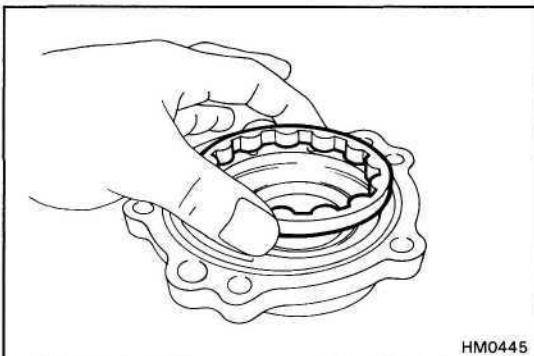

3. REMOVE OIL PUMP DRIVEN ROTOR
4. REMOVE O-RING

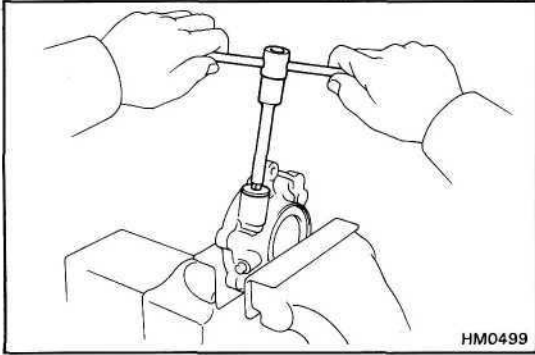

5. REMOVE SCREW PLUG, SPRING, BALL AND VALVE SEAT

(a) Using a hexagon wrench, remove the screw plug.

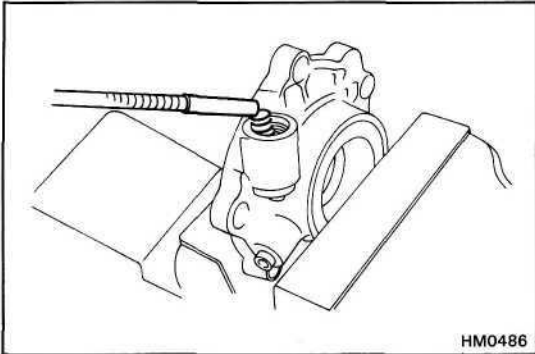

(b) Using a magnetic finger, remove the spring.

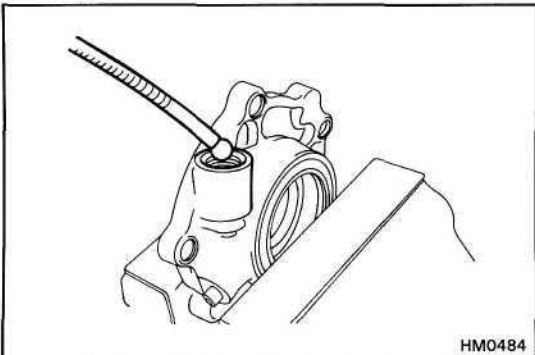

(c) Using a magnetic finger, remove the ball.

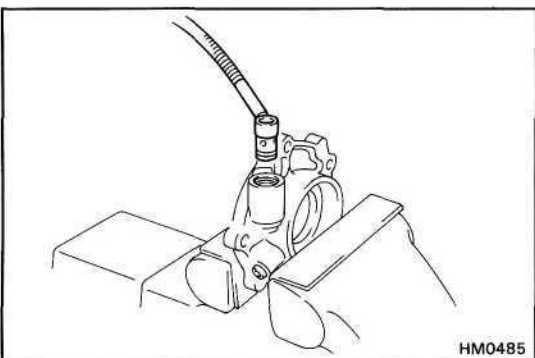

(d) Using a magnetic finger, remove the valve seat.

(e) Remove the O-ring from the valve seat.

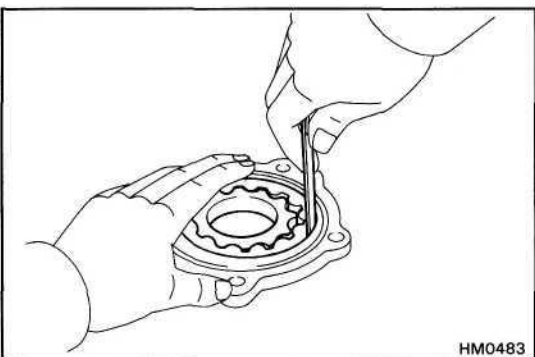

INSPECTION OF OIL PUMP COVER ASSEMBLY

1. CHECK BODY CLEARANCE OF DRIVEN ROTOR

Push the driven rotor to one side of the cover.

Using a feeler gauge, measure the clearance.

Standard clearance: 0.075 — 0.170 mm
(0.0030 - 0.0067 in.)

Maximum clearance: 0.170 mm (0.0067 in.)

If the clearance more than the limit, replace the driven rotor or pump cover.

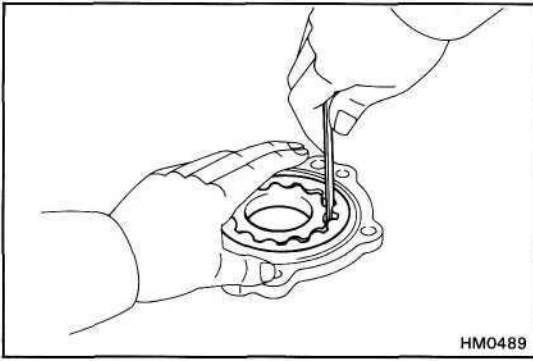

2. CHECK TIP CLEARANCE OF BOTH ROTORS

Using a feeler gauge, measure the clearance between both rotor tips.

Standard clearance: 0.10 — 0.22 mm
(0.0039 - 0.0087 in.)

Maximum clearance: 0.22 mm (0.0087 in.)

If the clearance more than the limit, replace the drive rotor or driven rotor.

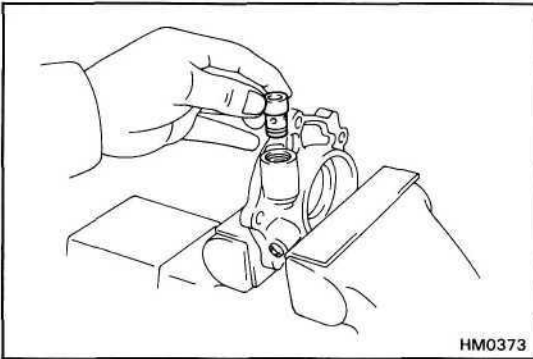

ASSEMBLY OF OIL PUMP COVER ASSEMBLY

1. INSTALL VALVE SEAT, BALL, SPRING AND SCREW PLUG

- (a) Install the O-ring to valve seat.
- (b) Apply gear oil to the valve seat.
- (c) Install the valve seat.

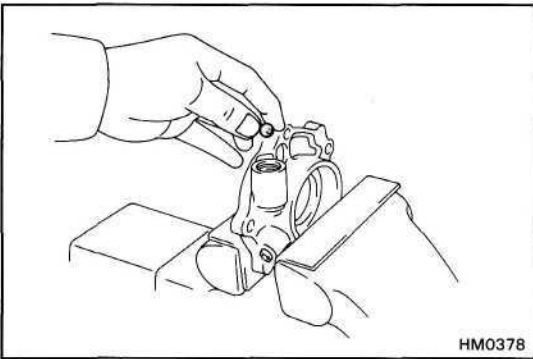

- (d) Apply gear oil to the ball.
- (e) Install the ball.

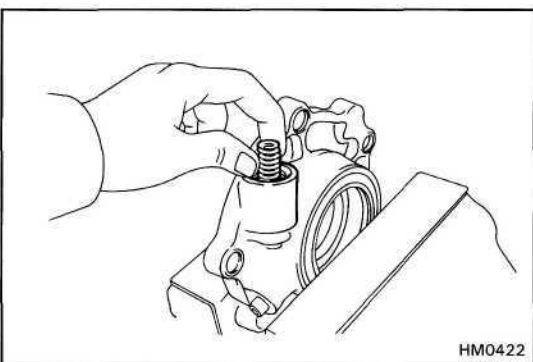

- (f) Install the spring.

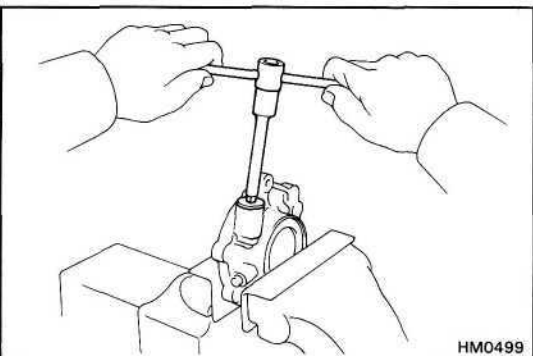

- (g) Using a hexagon wrench, install and torque the screw plug.

Torque: 185 kg-cm (13 ft-lb, 18 N-m)

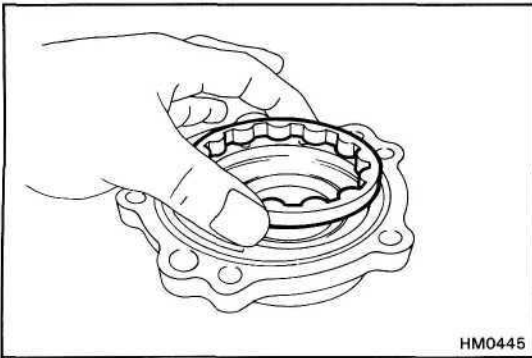
**2. INSTALL OIL PUMP DRIVEN ROTOR**

- (a) Apply gear oil to the driven rotor.
- (b) Install the oil pump driven rotor.

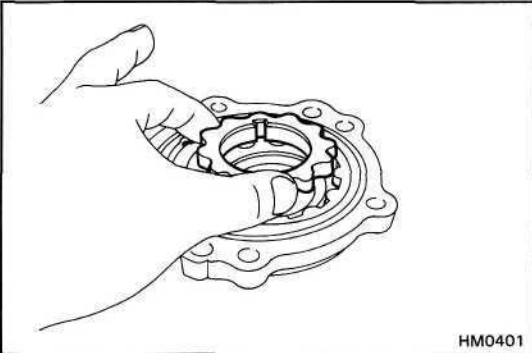
**3. INSTALL OIL PUMP DRIVE ROTOR**

- (a) Apply gear oil to the drive rotor.
- (b) Install the oil pump drive rotor.

4. INSTALL NEW O-RING**5. INSTALL NEW OIL SEAL**

ASSEMBLY OF TRANSMISSION

(See page MT-12 to 14)

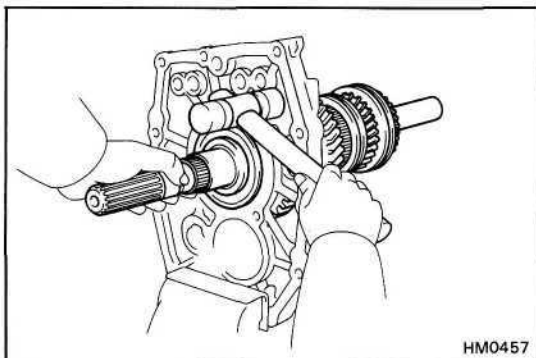

HM0457

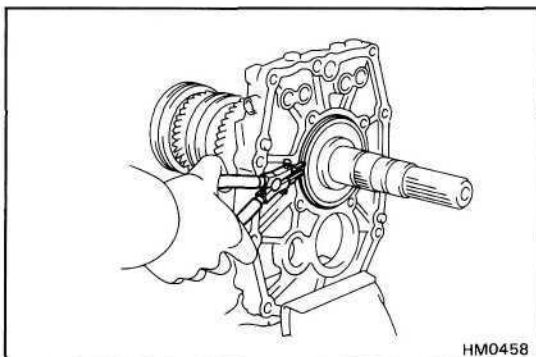

HM0458

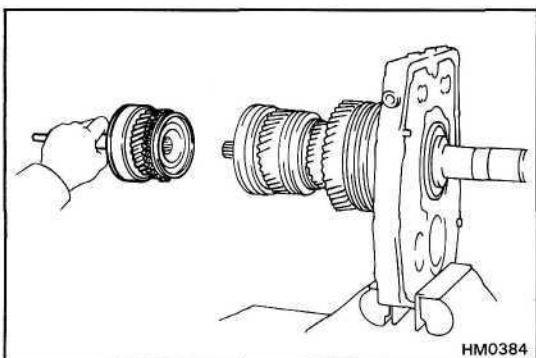

HM0384

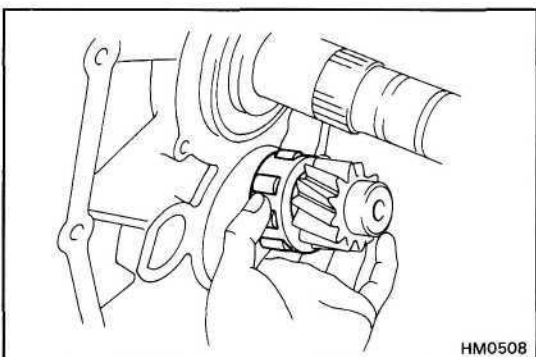

HM0508

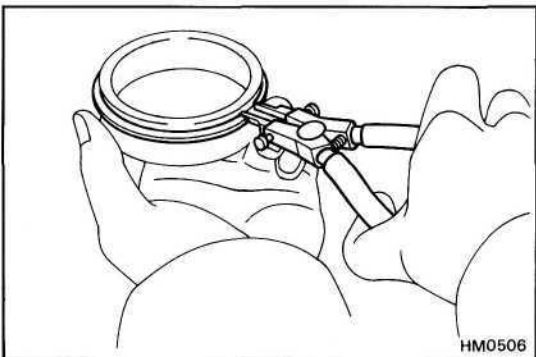

HM0506

1. INSTALL OUTPUT SHAFT ASSEMBLY TO INTERMEDIATE PLATE

- (a) Install the output shaft assembly into the intermediate plate by pulling on the output shaft assembly and tapping on the intermediate plate.
- (b) Using snap ring pliers, install the snap ring.

2. INSTALL INPUT SHAFT

- (a) Apply MP grease to the 12-needle roller bearing and install them into the input shaft.
- (b) Install the input shaft to the output shaft with the synchronizer ring slots aligned with the shifting keys.

3. INSTALL COUNTER GEAR

- (a) Install the counter gear into the intermediate plate and install the roller bearing.
- (b) Using snap ring pliers, install the snap ring to outer race.

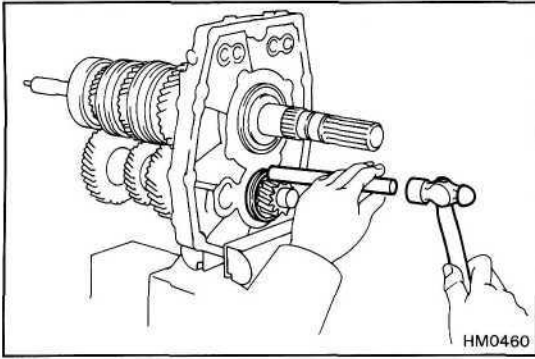

- (c) Install the counter gear rear bearing outer race with a brass bar and hammer.

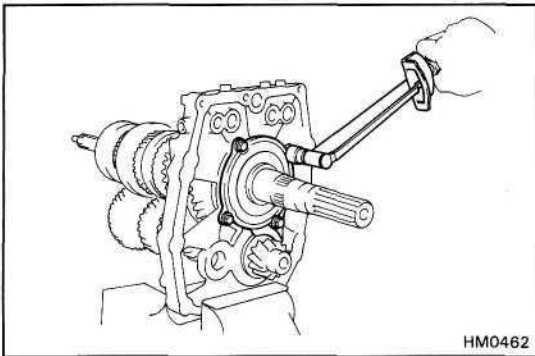

4. INSTALL REAR BEARING RETAINER

Install and torque the bolts.

Torque: 185 kg-cm (13 ft-lb, 18 N-rn)

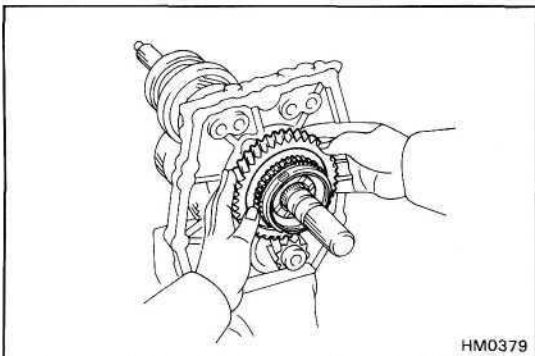

5. INSTALL REVERSE GEAR, REVERSE SYNCHRO ASSEMBLY AND NEEDLE ROLLER BEARING

- (a) Apply gear oil to the needle roller bearing.
 (b) Install the needle roller bearing and reverse gear with synchronizer ring.

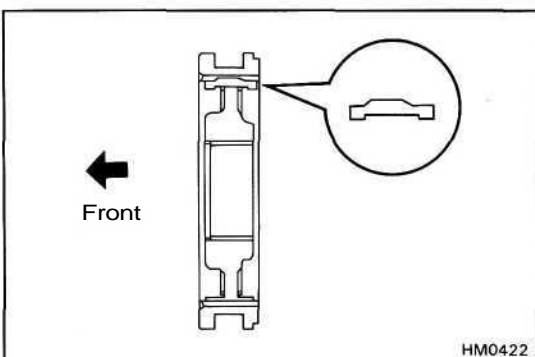

- (c) Install the clutch hub No.4 and shifting keys to the hub sleeve No.4.

- (d) Install the spring under the shifting keys.

NOTICE: Install the key springs positioned so that their end gaps are not in line.

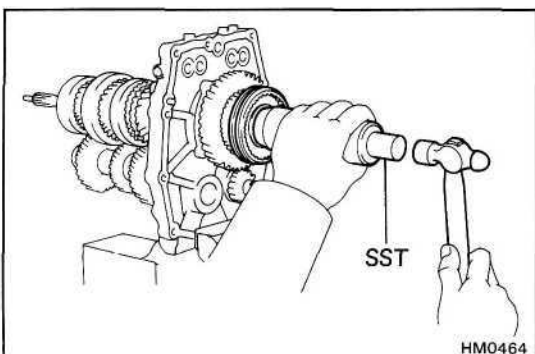

- (e) Using SST and a hammer, install the reverse synchro assembly.

SST 09316-60010 (09316-00010)

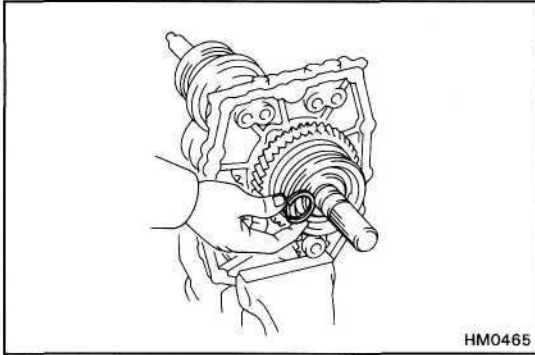

6. INSTALL SNAP RING

(a) Select a snap ring that will allow minimum axial play.

| Mark | Thickness mm (in.) |
|------|-------------------------------|
| A | 2.40 - 2.45 (0.0945 - 0.0965) |
| B | 2.45 - 2.50 (0.0965 - 0.0984) |
| C | 2.50 - 2.55 (0.0984 - 0.1004) |
| D | 2.55 - 2.60 (0.1004 - 0.1024) |
| E | 2.60 - 2.65 (0.1024 - 0.1044) |
| F | 2.65 - 2.70 (0.1044 - 0.1063) |

(b) Using a brass bar and a hammer, install the snap ring.

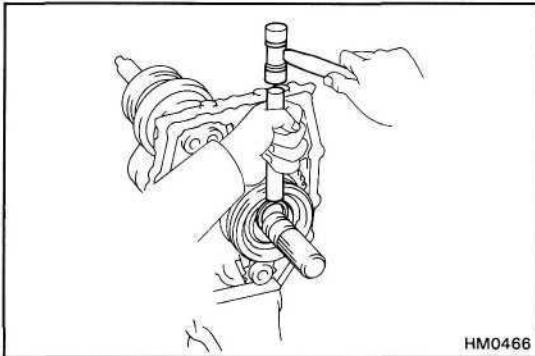

7. MEASURE REVERSE GEAR THRUST CLEARANCE

Using a feeler gauge, measure the reverse gear clearance.

**Standard clearance: 0.1 — 0.67 mm
(0.0039 - 0.0264 in.)**

Maximum clearance: 0.67 mm (0.0264 in.)

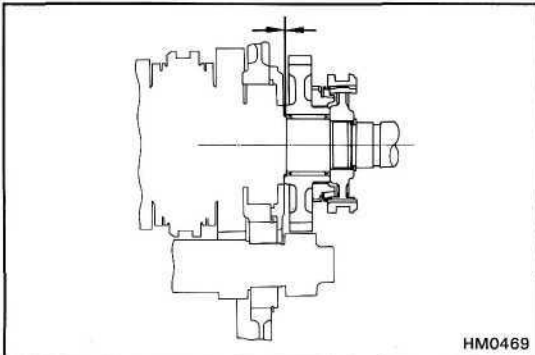

8. INSTALL SHIFT FORK SHAFT NO.2 AND SHIFT FORK NO.2

(a) Place shift fork No.2 into the groove of hub sleeve No.2.

(b) Install shift fork shaft No.2 to shift fork No.2 and intermediate plate.

(c) Install and torque the set bolt.

Torque: 370 kg-cm (27 ft-lb, 36 N-m)

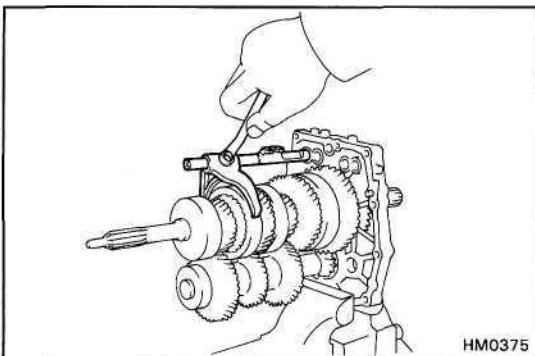

9. INSTALL SHIFT FORK SHAFT NO.1 AND SHIFT FORK NO.1

(a) Using a magnetic finger, install the interlock pin into the intermediate plate.

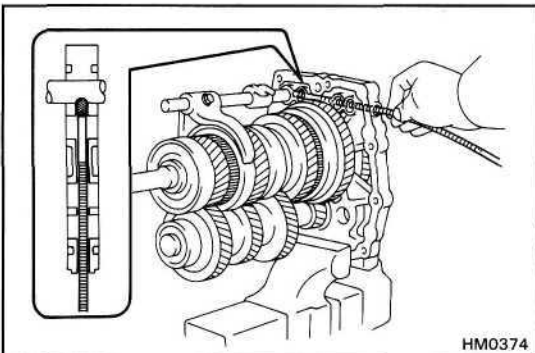

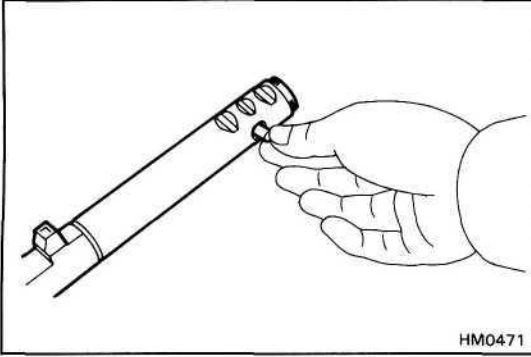

- (b) Install the interlock pin into the shaft hole.

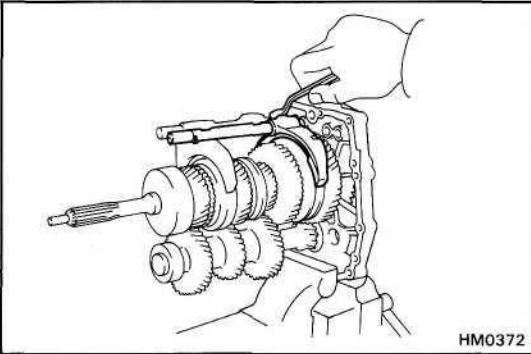

- (c) Place shift fork No.1 into the groove of hub sleeve No.1.

- (d) Install shift fork shaft No.1 to shift fork No.1 and intermediate plate.

- (e) Install and torque the bolt.

Torque: 370 kg-cm (27 ft-lb, 36 N-m)

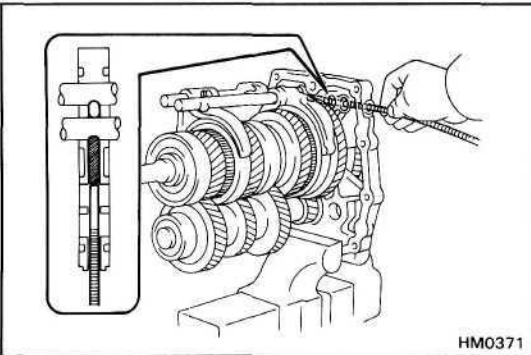

10. INSTALL SHIFT FORK SHAFT NO.3, REVERSE SHIFT HEAD AND SHIFT FORK NO.3

- (a) Using a magnetic finger, install the interlock pin into the intermediate plate.

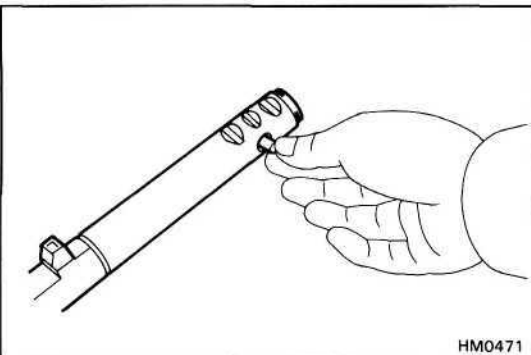

- (b) Install the interlock pin into the shaft hole.

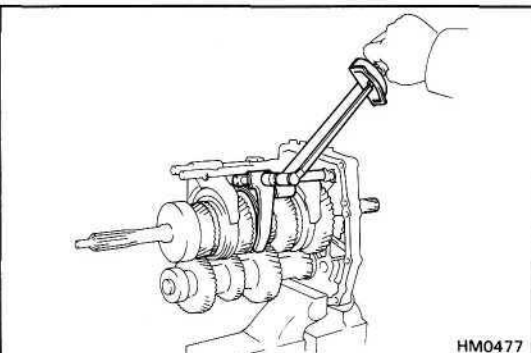

- (c) Place shift fork No.3 into the groove of hub sleeve No.3.

- (d) Install shift fork shaft No.3 to shift fork No.3, reverse shift head and shift fork through the intermediate plate.

- (e) Install and torque the set bolt.

Torque: 370 kg-cm (27 ft-lb, 36 N-m)

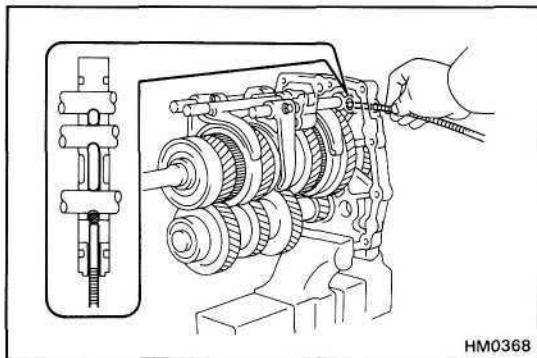

11. INSTALL SHIFT FORK SHAFT NO.3 OR NO.4 AND REVERSE SHIFT FORK

(a) Using a magnetic finger, install the locking ball into the intermediate plate.

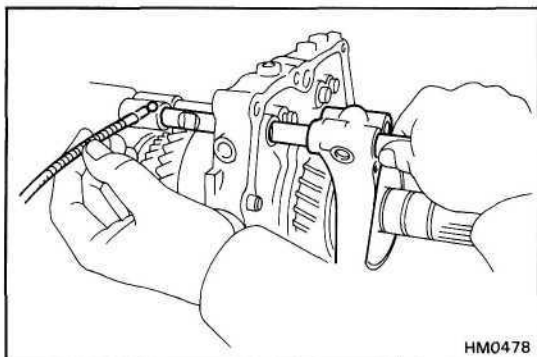

(b) Place reverse shift fork into the groove of hub sleeve No.3 or No.4.

(c) Install shift fork shaft No.3 or No.4 to reverse shift fork and shift fork through the intermediate plate.

(d) Using a magnetic finger, install the locking ball into the reverse shift head.

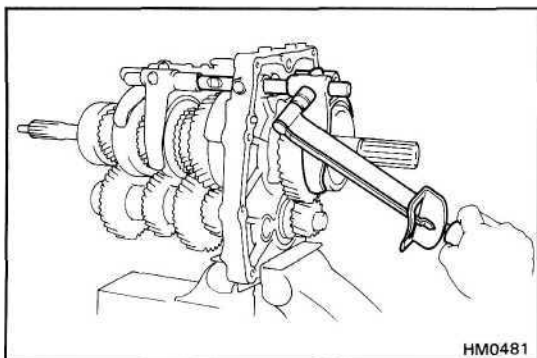

(e) Install and torque the set bolt.

Torque: 4-Speed **350 kg-cm (25 ft-lb, 34 N-m)**
 5-Speed **370 kg-cm (27 ft-lb, 36 N-m)**

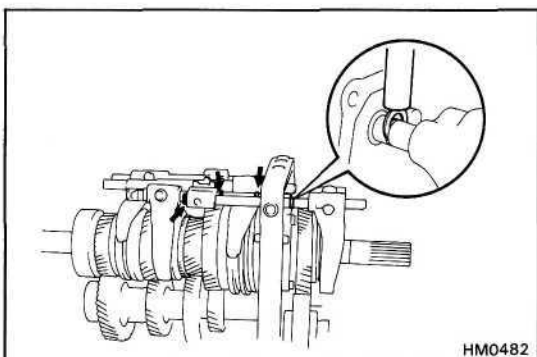

12. INSTALL FORK SHAFT SNAP RINGS

Using a brass bar and hammer, tap in the snap rings.

4-Speed: One snap ring

5-Speed: Four snap rings.

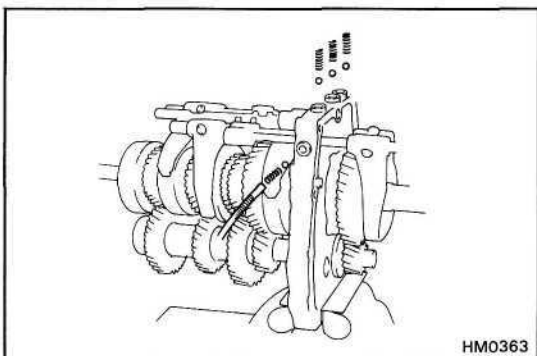

13. INSTALL LOCKING BALLS, SPRINGS AND SCREW PLUGS

(a) Install the locking balls, springs and screw plugs.

4-Speed: Three locking balls and springs

5-Speed: Four locking balls and springs

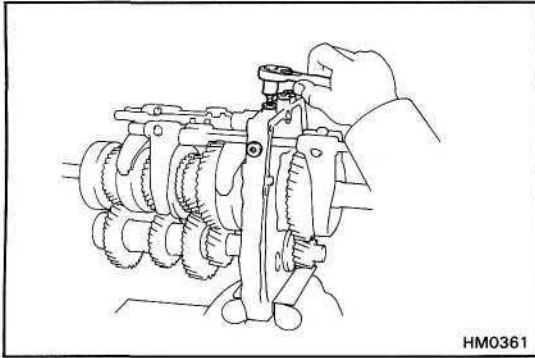

HM0361

(b) Apply liquid sealer to the plug threads.

Sealant: Part No.08833-00080, THREE BOND 1344, LOCTITE 242 or equivalent

(c) Using a torx socket wrench, torque the screw plug.
(Torx socket wrench T40 09042-00020)

Torque: 190 kg-cm (14 ft-lb, 19 N-m)

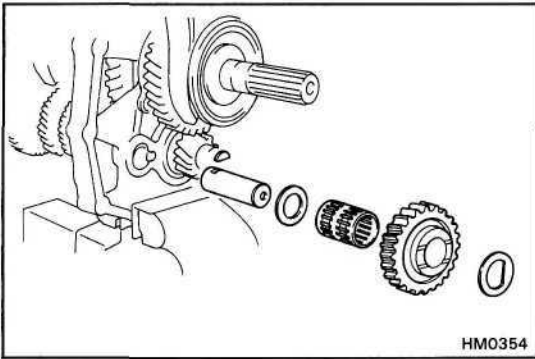

HM0354

14. INSTALL REVERSE IDLER GEAR TO INTERMEDIATE PLATE

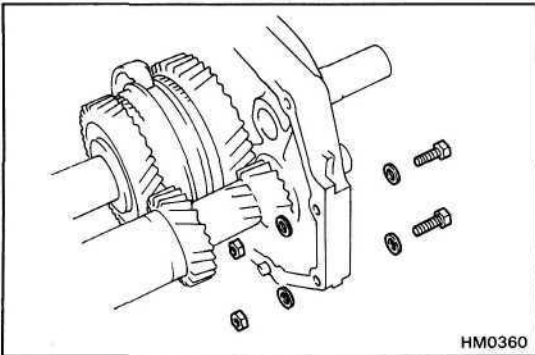

HM0360

15. DISMOUNT INTERMEDIATE PLATE FROM VISE

(a) Dismount the intermediate plate from the vise.

(b) Remove the bolts, nuts and plate washers.

16. INSTALL OIL RECEIVER TO INTERMEDIATE PLATE

(a) Install the oil receiver.

(b) Install and torque the three bolts.

Torque: 185 kg-cm (13 ft-lb, 18 N-m)

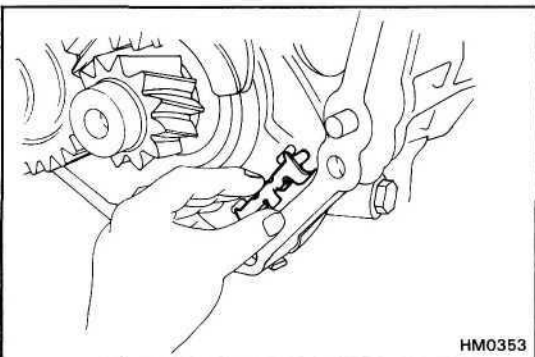

HM0353

17. INSTALL MAGNET TO INTERMEDIATE PLATE

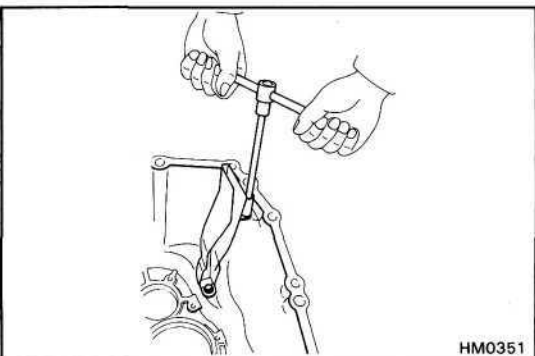

HM0351

18. INSTALL OIL RECEIVER TO FRONT CASE

Install and torque the two bolts.

Torque: 120 kg-cm (9 ft-lb, 12 N-m)

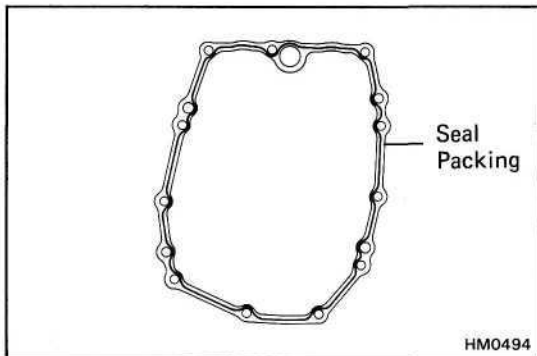

19. ASSEMBLE TRANSMISSION CASE AND INTERMEDIATE PLATE

- (a) Remove any packing material and be careful not to drop oil on the contacting surface of the transmission case.
- (b) Apply seal packing to the transmission case as shown in the figure.

Seal packing: Part No.08826-00090, THREE BOND 1281 or equivalent

HINT: Install the transmission case as soon as the seal packing is applied.

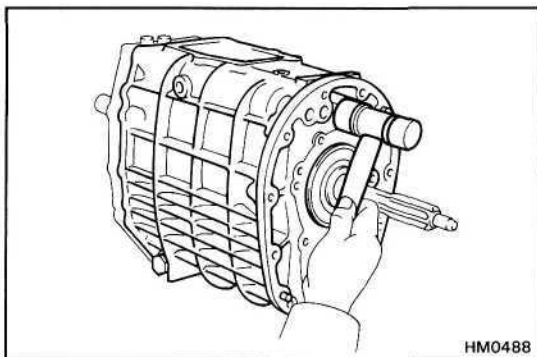

- (c) Align each bearing outer race, each fork shaft end and reverse idler gear shaft end with the case installation holes, and install the case.
- (d) Using a plastic hammer, tap on the case to install it.

20. INSTALL BEARING SNAP RINGS

Using snap ring pliers, install the two snap rings to the input shaft bearing and counter gear front bearing.

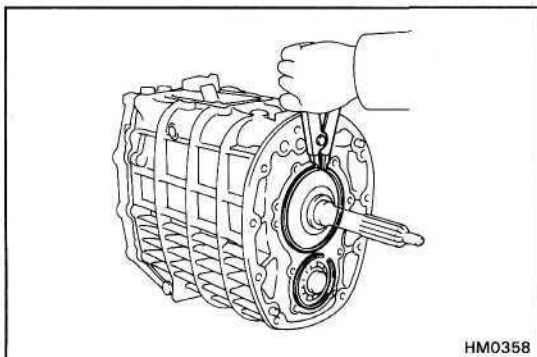

21. INSTALL FRONT BEARING RETAINER

- (a) Remove any packing material and be careful not to drop oil on the contacting surfaces of the front bearing retainer.
- (b) Apply seal packing to the retainer as shown in the figure and install it to the transmission case.

Seal packing: Part No.08826-00090, THREE BOND 1281 or equivalent

HINT: Install the front bearing retainer as soon as the seal packing is applied.

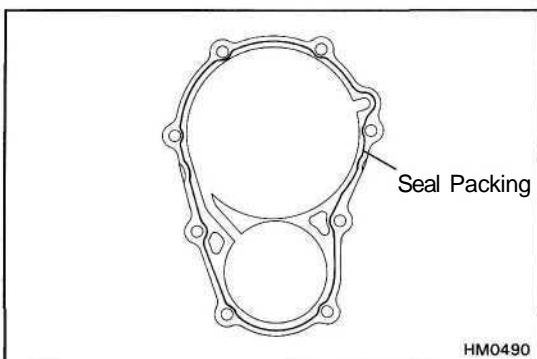

- (c) Apply liquid sealer to the bolt threads.

Sealant: Part No.08833-00080. THREE BOND 1344, LOCTITE 242 or equivalent

- (d) Install and torque the eight bolts.

Torque: 170 kg-cm (12 ft-lb, 16 N-m)

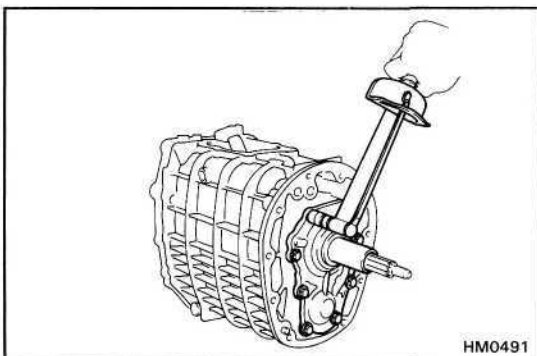

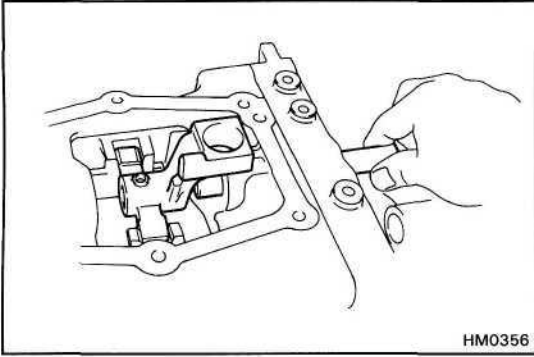

22. INSTALL SHIFT LEVER SHAFT AND SHIFT LEVER HOUSING

- (a) Install the shift lever shaft and shift lever housing.

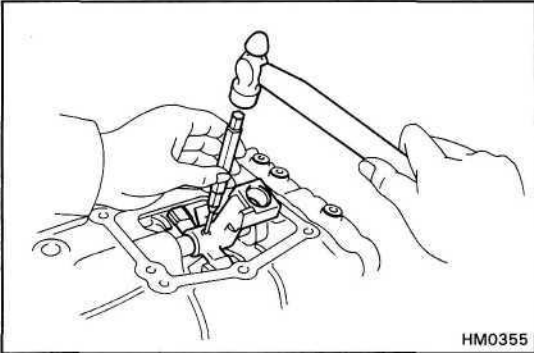

- (b) Using a pin punch and hammer, drive in the slotted spring pin.

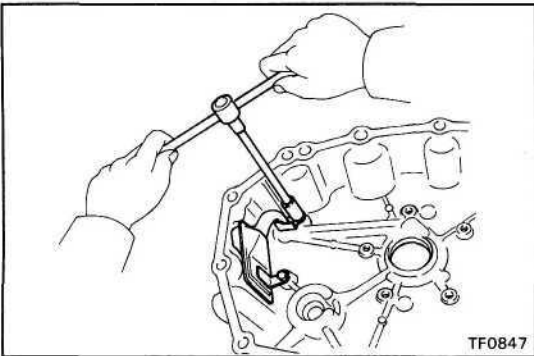

23. INSTALL OIL STRAINER TO TRANSFER ADAPTOR

- (a) Install the oil strainer.
 (b) Install and torque the two bolts.

Torque: 120 kg-cm (9 ft-lb, 12 N-m)

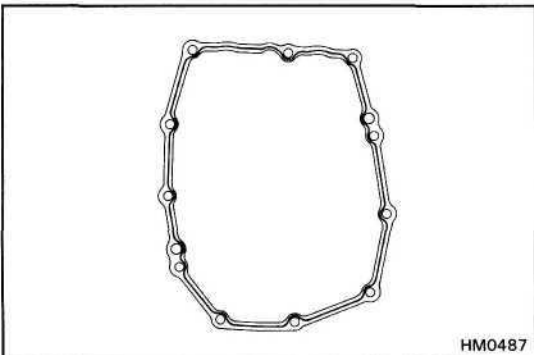

24. INSTALL TRANSFER ADAPTOR

- (a) Remove any packing material and be careful not to drop oil on the contacting surfaces of the transfer adaptor.

- (b) Apply seal packing to the transfer adaptor as shown.

Seal packing: Part No.08826-00090, THREE BOND 1281 or equivalent

HINT: Install the transfer adaptor as soon as the seal packing is applied.

- (c) Install the transfer adaptor.

- (d) Install and torque the eleven bolts.

Torque: 380 kg-cm (27 ft-lb, 37 N-m)

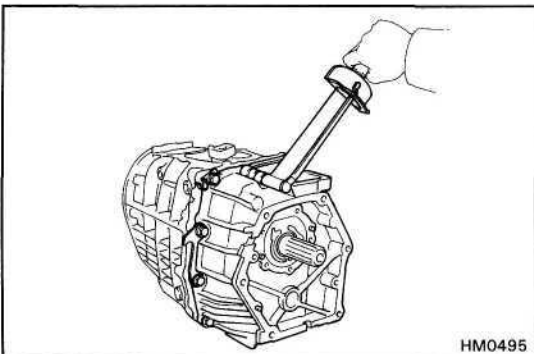

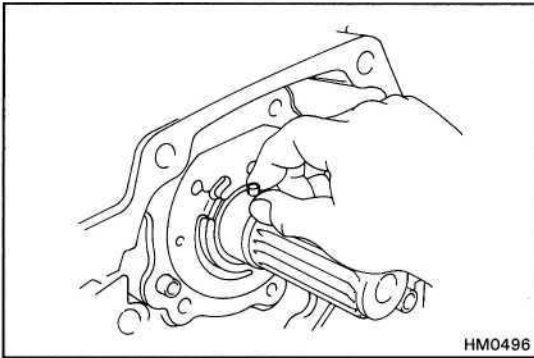

25. INSTALL OIL PUMP BODY

- (a) Apply MP grease to the straight pin.
- (b) Install the two straight pins.

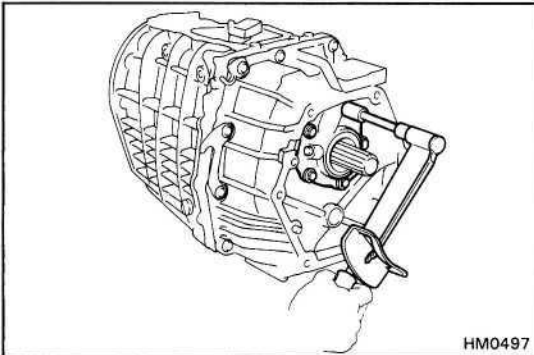

- (c) Install the oil pump body.
- (d) Apply liquid sealer to the bolt threads.

Sealant: Part No. 08833-00080, THREE BOND 1344, LOCTITE 242 or equivalent.

- (e) Install and torque the five bolts.

Torque: 170 kg-cm (12 ft-lb. 17 N-m)

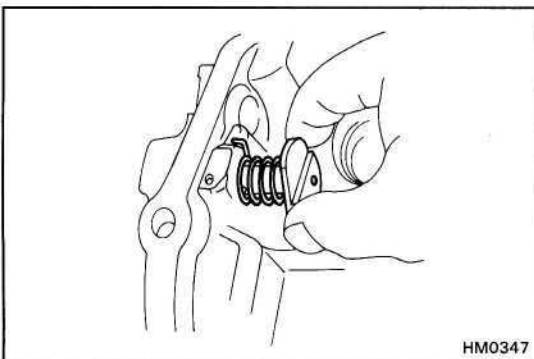

**26. (H150F, H151F)
INSTALL REVERSE RESTRICT PIN**

- (a) Install the reverse restrict pin to the shift control retainer.

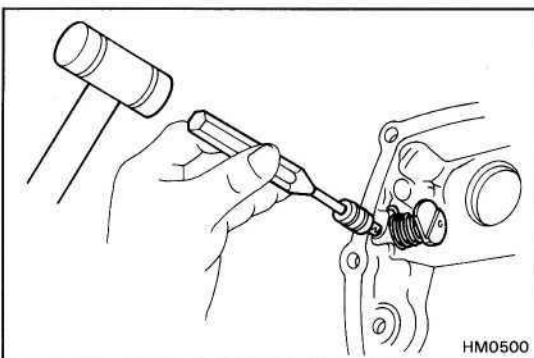

- (b) Using a hammer, tap in the slotted spring pin as shown.

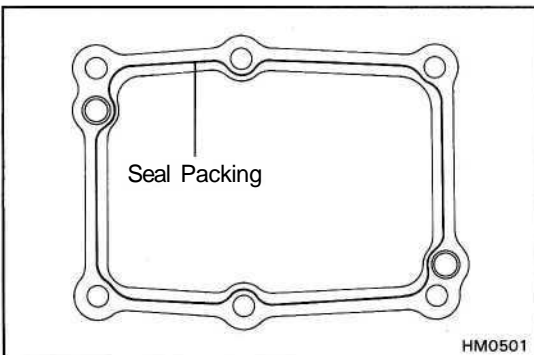

27. INSTALL SHIFT LEVER CONTROL RETAINER

- (a) Remove any packing material and be careful not to drop oil on the contacting surfaces of the shift lever control retainer as shown.

(b) Apply seal packing to the shift lever control retainer.
Seal packing: Part No.08826-00090, THREE BOND 1281 or equivalent

HINT: Install the shift lever control retainer as soon as the seal packing is applied.

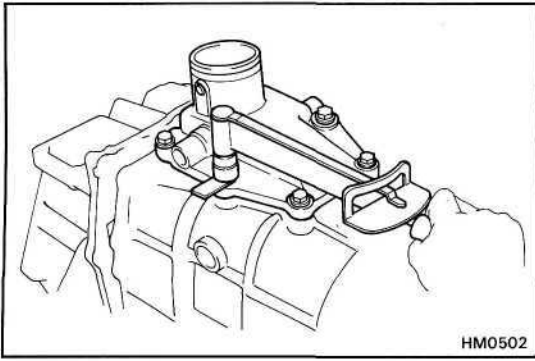

(c) Install and torque the six bolts.

Torque: 170 kg-cm (12 ft-lb, 17 N-m)

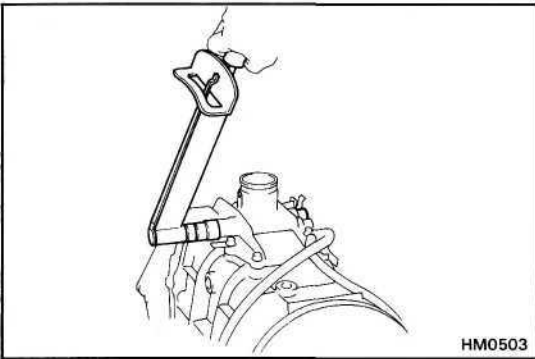

28. INSTALL TWO RESTRICT PINS

Torque: 380 kg-cm (27 ft-lb, 37 N-m)

29. INSTALL BREATHER HOSE

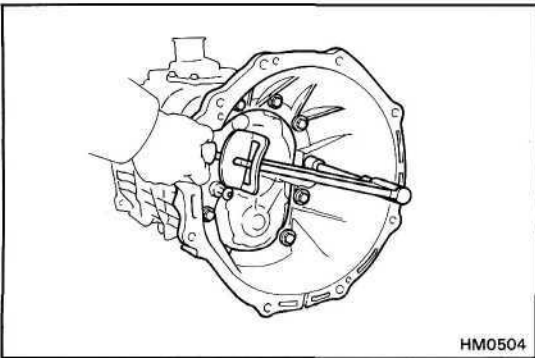

30. INSTALL CLUTCH HOUSING

(a) Install the clutch housing.

(b) Install and torque the ten bolts.

Torque: 380 kg-cm (27 ft-lb, 37 N-m)

31. INSTALL BACK-UP LIGHT SWITCH

Torque: 450 kg-cm (33 ft-lb, 44 N-m)

32. INSTALL RELEASE FORK AND BEARING