PROPELLER SHAFT

	Page
PRECAUTIONS.....	PR-2
TROUBLESHOOTING.....	PR-2
PROPELLER SHAFT.....	PR-2

PR

PRECAUTIONS

Be careful not to grip the propeller shaft tube too tightly in the vise as this will cause deformation.

TROUBLESHOOTING

Problem	Possible cause	Remedy	Page
Noise	Sleeve yoke spline worn	Replace sleeve yoke	PR-4
	Spider bearing worn or stuck	Replace spider bearing	PR-4
Vibration	Propeller shaft runout	Replace propeller shaft	PR-3
	Propeller shaft imbalance	Balance propeller shaft	
	Sleeve yoke spline stuck	Replace sleeve yoke	PR-4

PROPELLER SHAFT COMPONENTS

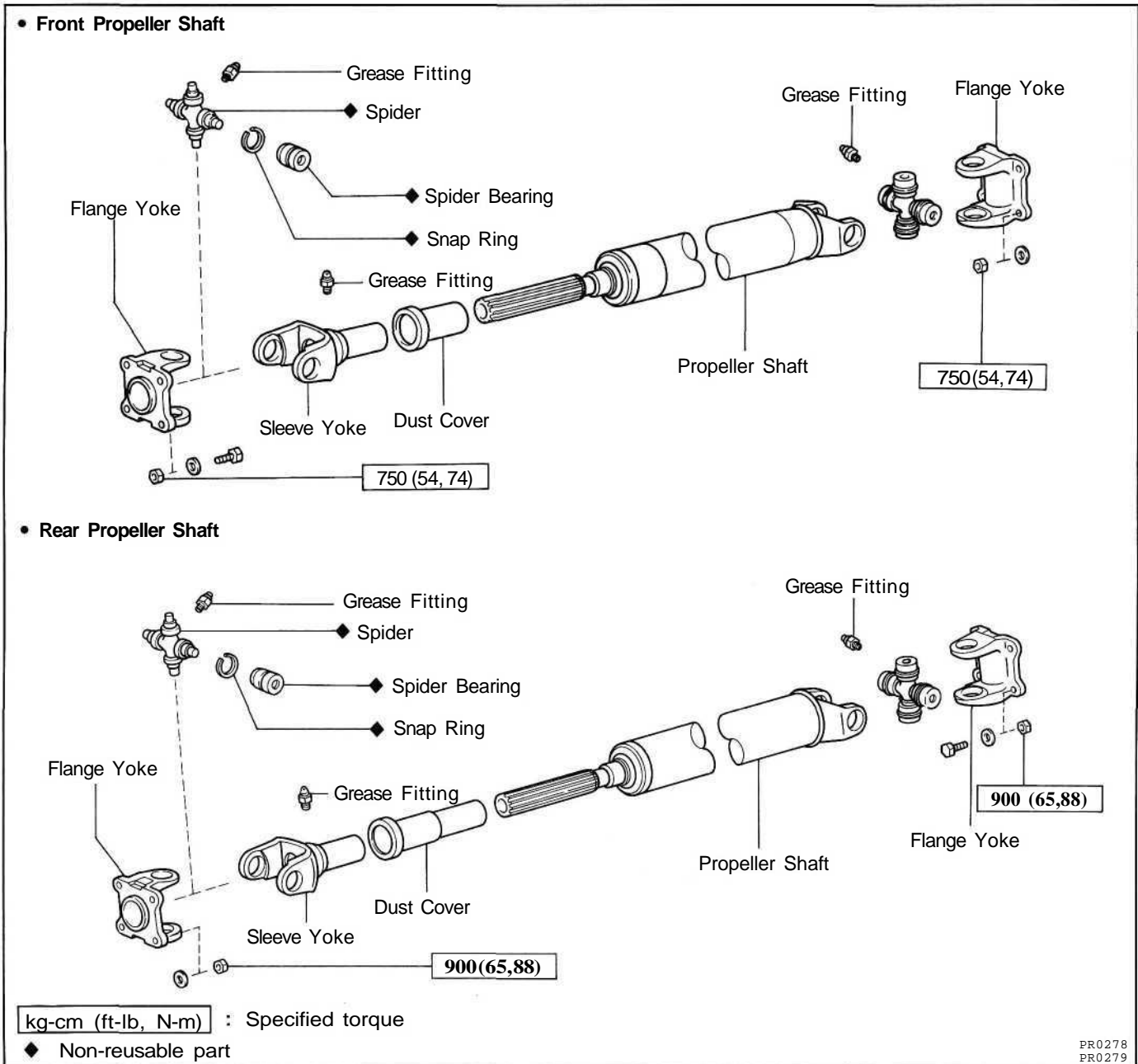

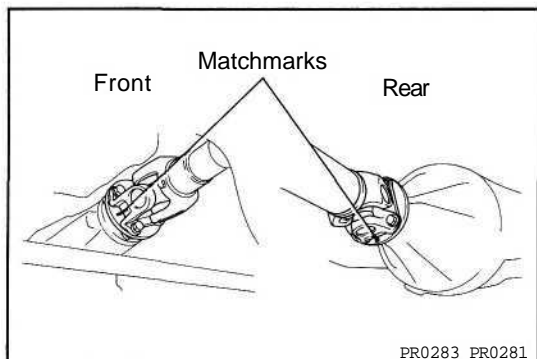

REMOVAL OF FRONT AND REAR PROPELLER SHAFTS

1. DISCONNECT PROPELLER SHAFT FLANGE FROM COMPANION FLANGE ON DIFFERENTIAL

- (a) Put matchmarks on the flanges.
- (b) Remove the four bolts and nuts.

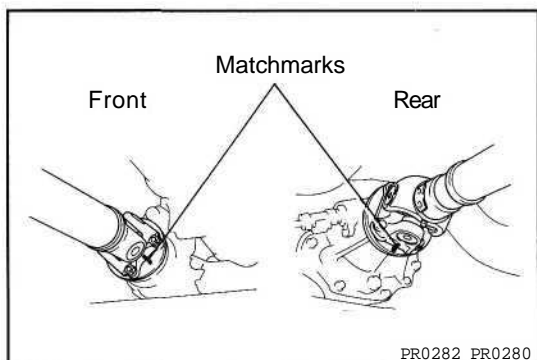

2. DISCONNECT PROPELLER SHAFT FLANGE FROM COMPANION FLANGE ON TRANSFER

- (a) Put matchmarks on the flange.
- (b) Remove the four nuts.
- (c) Remove the propeller shaft.

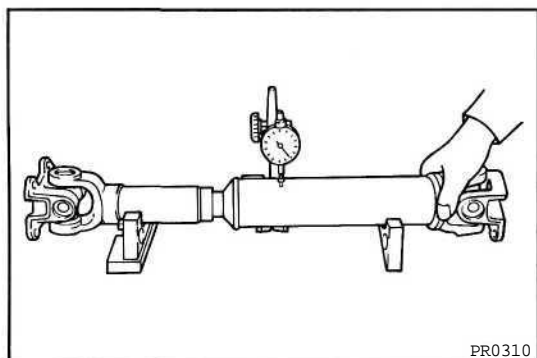

INSPECTION OF PROPELLER SHAFT COMPONENTS

1. INSPECT FRONT AND REAR PROPELLER SHAFTS FOR DAMAGE OR RUNOUT

If shaft runout is greater than maximum, replace the shaft.

Maximum runout: 0.8 mm (0.031 in.)

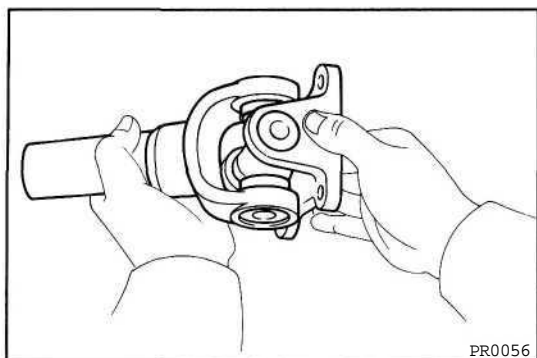

2. INSPECT SPIDER BEARINGS

- (a) Inspect the spider bearings for wear or damage.
- (b) Check the spider bearing axial play by turning the yoke while holding the shaft tightly.

Bearing axial play: Less than 0.05 mm (0.0020 in.)

If necessary, replace the spider bearing.

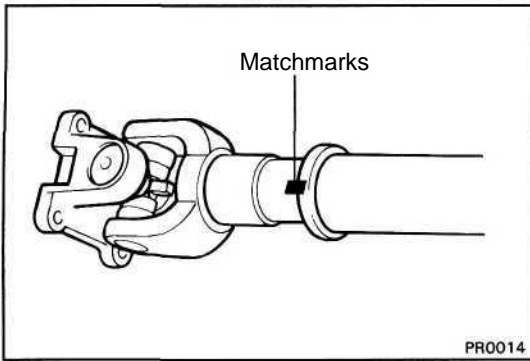

DISASSEMBLY OF PROPELLER SHAFT

1. REMOVE SLEEVE YOKE FROM PROPELLER SHAFT

- (a) Place matchmarks on the sleeve yoke and shaft.
- (b) Pull out the sleeve yoke from the shaft.

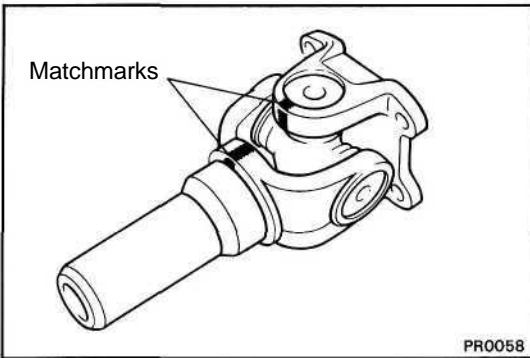

2. REMOVE SPIDER BEARING

- (a) Put matchmarks on the sleeve yoke and flange.

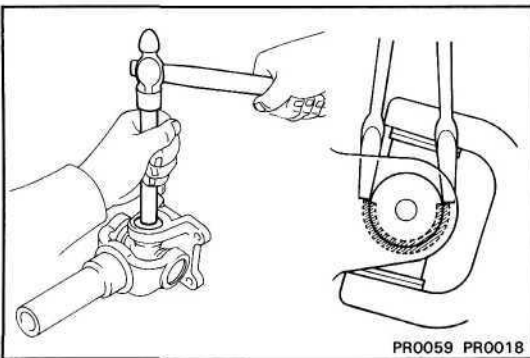

- (b) Slightly tap in the bearing outer races.
- (c) Using two screwdrivers, remove the four snap rings from the grooves.

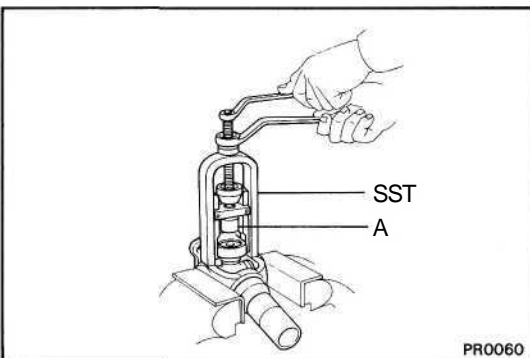

- (d) Using SST, push out the bearing from the flange.
SST 09332-25010

HINT: Sufficiently raise the part indicated by A so that it does not come into contact with the bearing.

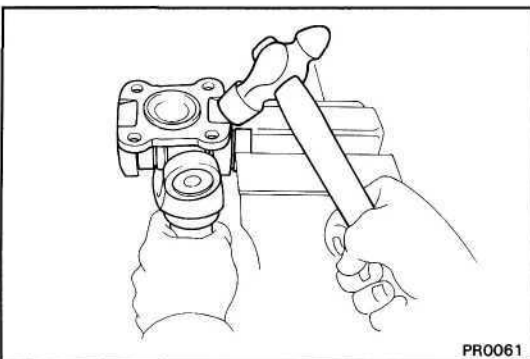

- (e) Clamp the bearing outer race in a vise and tap off the flange with a hammer.

HINT: Remove the bearing on the opposite side in the same procedure.

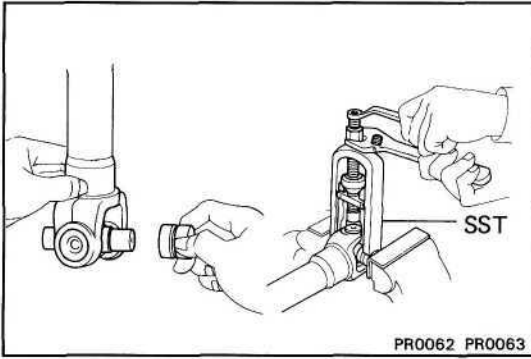

- (f) Install the two removed bearing outer races to the spider.
- (g) Using SST, push out the bearing from the yoke.
SST 09332-25010

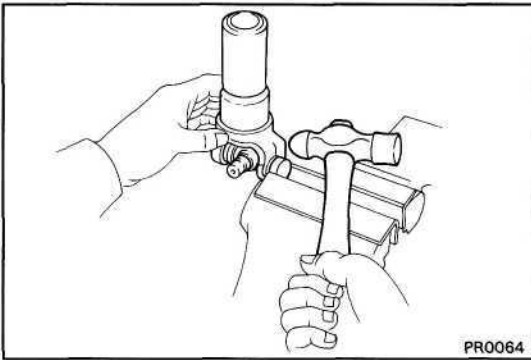

- (h) Clamp the outer bearing race in a vise and tap off the yoke with a hammer.
- HINT: Remove the bearing on the opposite side in the same procedure.

ASSEMBLY OF PROPELLER SHAFT

(See page PR-2)

HINT: When replacing the spider, be sure that the grease fitting assembly hole is facing in the direction shown in figure.

SPIDER GREASE FITTING ASSEMBLY DIRECTION
Front Propeller Shaft

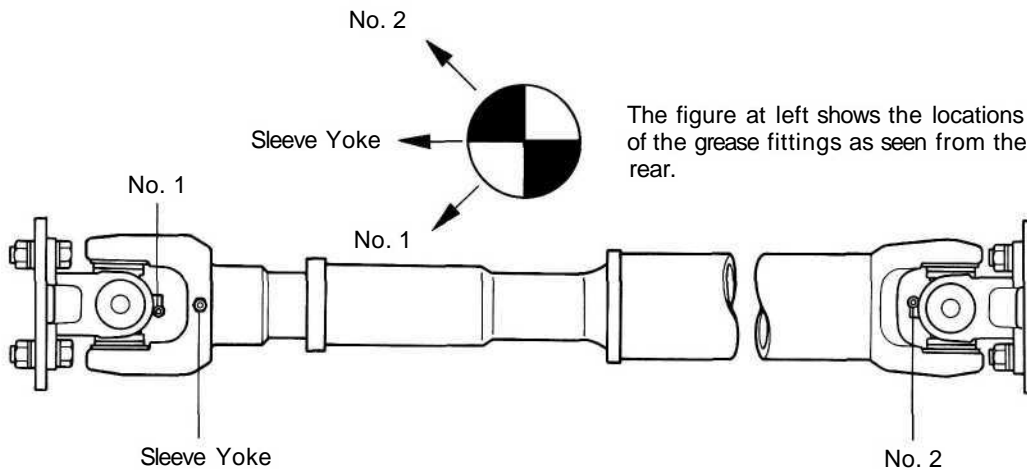

SPIDER GREASE FITTING ASSEMBLY DIRECTION
Rear Propeller Shaft

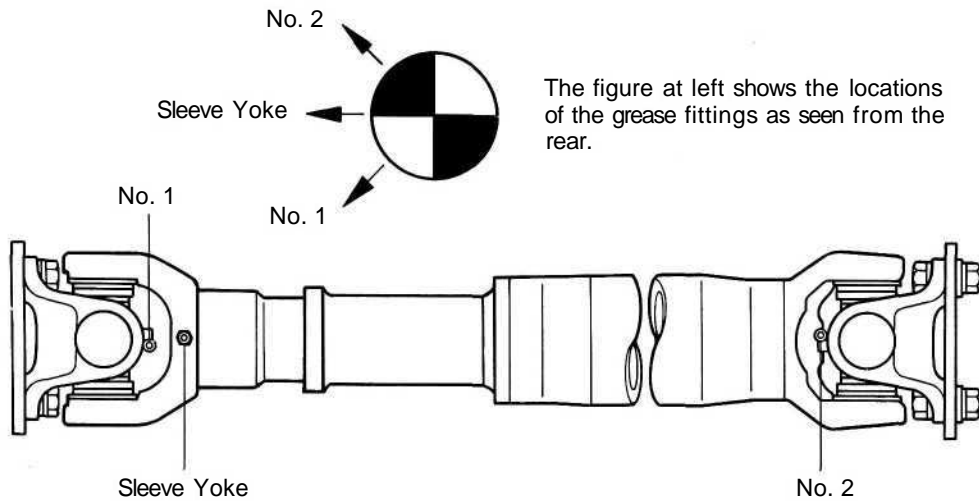

The figure at left shows the locations of the grease fittings as seen from the rear.

PR0285

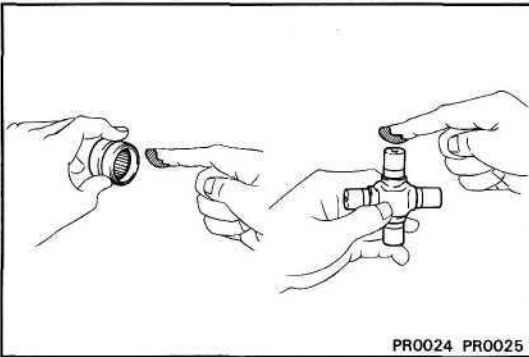

PR0024 PR0025

1. INSTALL SPIDER BEARINGS

- (a) Apply MP grease to the spider and bearings.
- HINT: Be careful not to apply too much grease.

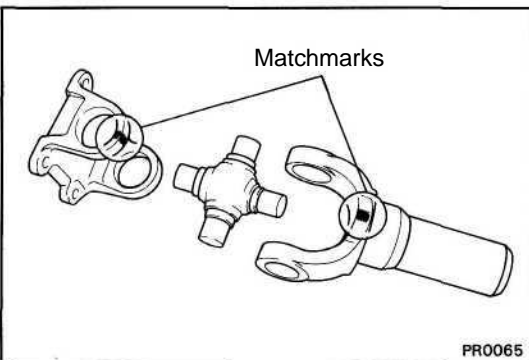

PR0065

- (b) Align the matchmarks on the yoke and flange.

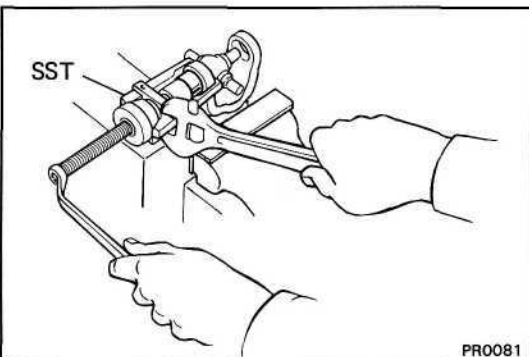

PR0081

- (c) Fit the new spider into the yoke.
 - (d) Using SST, install the new bearing on the spider.
- SST 09332-25010

• Front Propeller Shaft

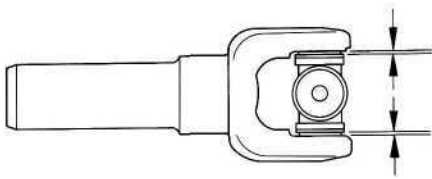

• Rear Propeller Shaft

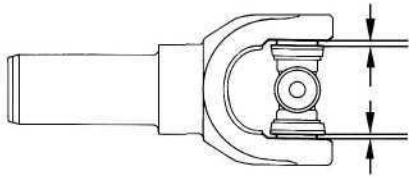

PR0286
PR0068

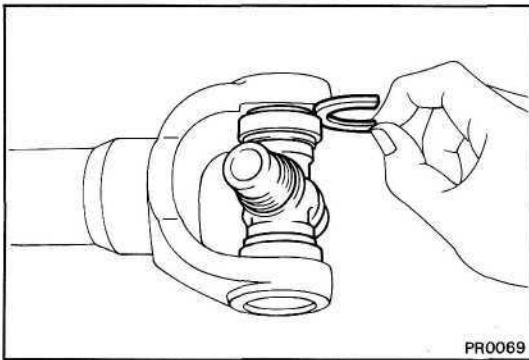

PR0069

- (e) Using SST, adjust both bearings so that the snap ring grooves are at maximum and equal widths.

- (f) Install two snap rings of equal thickness which will allow 0 - 0.05 mm (0 — 0.0020 in.) axial play.

HINT: Do not reuse the snap rings.

Thickness of snap ring

Front Propeller Shaft

Color	Mark	Thickness mm (in.)
—	1	2.100 - 2.150 (0.0827 - 0.0846)
—	2	2.150 - 2.200 (0.0846 - 0.0866)
—	3	2.200 - 2.250 (0.0866 - 0.0886)
Brown	—	2.250 - 2.300 (0.0886 - 0.0906)
Blue	—	2.300 - 2.350 (0.0906 - 0.0925)
—	6	2.350 - 2.400 (0.0925 - 0.0945)
—	7	2.400 - 2.450 (0.0945 - 0.0984)
—	8	2.450 - 2.500 (0.0965 - 0.0984)

Rear Propeller Shaft

Thickness mm (in.)	Color
2.00 (0.0787)	—
2.03 (0.0799)	Brown
2.06 (0.0811)	Blue
2.09 (0.0823)	—

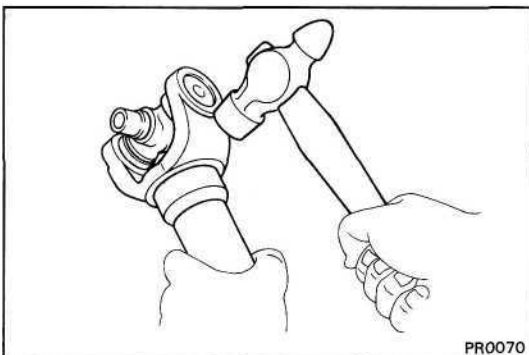

PR0070

- (g) Using a hammer, tap the yoke until there is no clearance between the bearing outer race and snap ring.

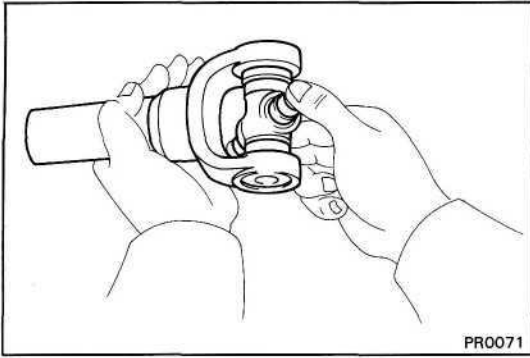

- (h) Check that the spider bearing moves smoothly.
- (i) Check the spider bearing axial play.

Bearing axial play: Less than 0.05 mm (0.0020 in.)

HINT: Install new spider bearings on the flange side in the procedure described above.

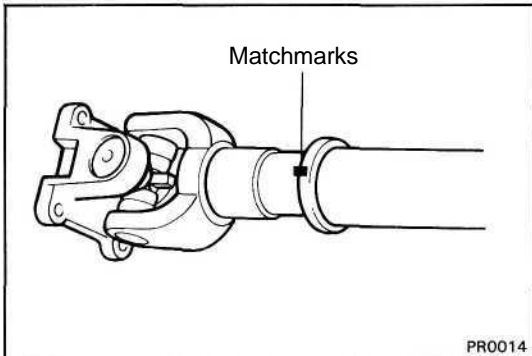

2. INSERT SLEEVE YOKE INTO PROPELLER SHAFT

- (a) Apply MP grease to the propeller shaft spline and sleeve yoke sliding surface.
- (b) Align the matchmarks on the sleeve and propeller shaft.
- (c) Install the propeller shaft into the sleeve yoke.

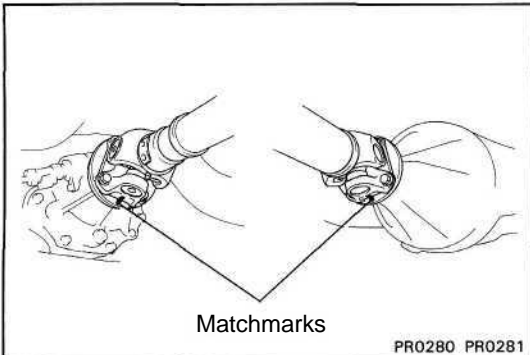

INSTALLATION OF FRONT AND REAR PROPELLER SHAFTS

1. CONNECT PROPELLER SHAFT FLANGE TO COMPANION FLANGE ON TRANSFER

- (a) Align the matchmarks on the flanges and connect the flanges with four nuts.
- (b) Torque the nuts.

Torque:

Front Propeller Shaft

750 kg-cm (54 ft-lb, 74 N-m)

Rear Propeller Shaft

900 kg-cm (65 ft-lb, 88 N-m)

HINT: When installing the washers, put them properly in place.

2. CONNECT PROPELLER SHAFT FLANGE ON DIFFERENTIAL

- (a) Align the matchmarks on the flanges and connect the flanges with four bolts and nuts.
- (b) Torque the bolts and nuts.

Torque:

Front Propeller Shaft

750 kg-cm (54 ft-lb, 74 N-m)

Rear Propeller Shaft

900 kg-cm (65 ft-lb, 88 N-m)

HINT: When installing the washers, put them properly in place.

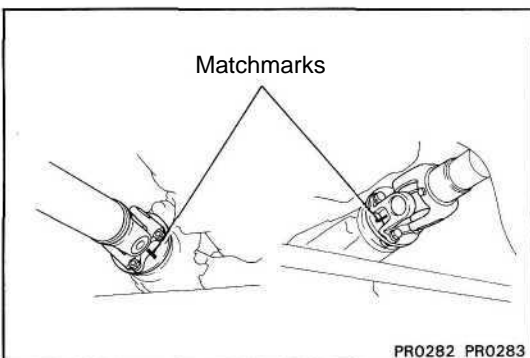

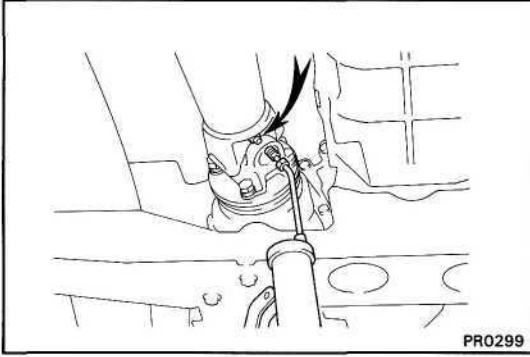

3. APPLY MP GREASE TO GREASE FITTING

With a grease gun, pump the MP grease into each fitting until it begins to flow around the oil seal.