

# WINCH

	Page
<b>MECHANICAL WINCH.....</b>	<b>WI-2</b>
Power Take-Off (P.T.O.).....	WI-2
Drive Shaft.....	WI-11
Winch Assembly.....	WI-14
<b>ELECTRIC WINCH.....</b>	<b>WI-25</b>
On-Vehicle Inspection.....	WI-25
Removal and Installation of Winch Assembly. . . .	WI-27
Winch Assembly.....	WI-28
Winch Components.....	WI-33
Winch Motor.....	WI-44
Magnet Switch No.1.....	WI-49
Magnet Switch No.2.....	WI-51

# MECHANICAL WINCH Power Take-Off (P.T.O.) COMPONENTS

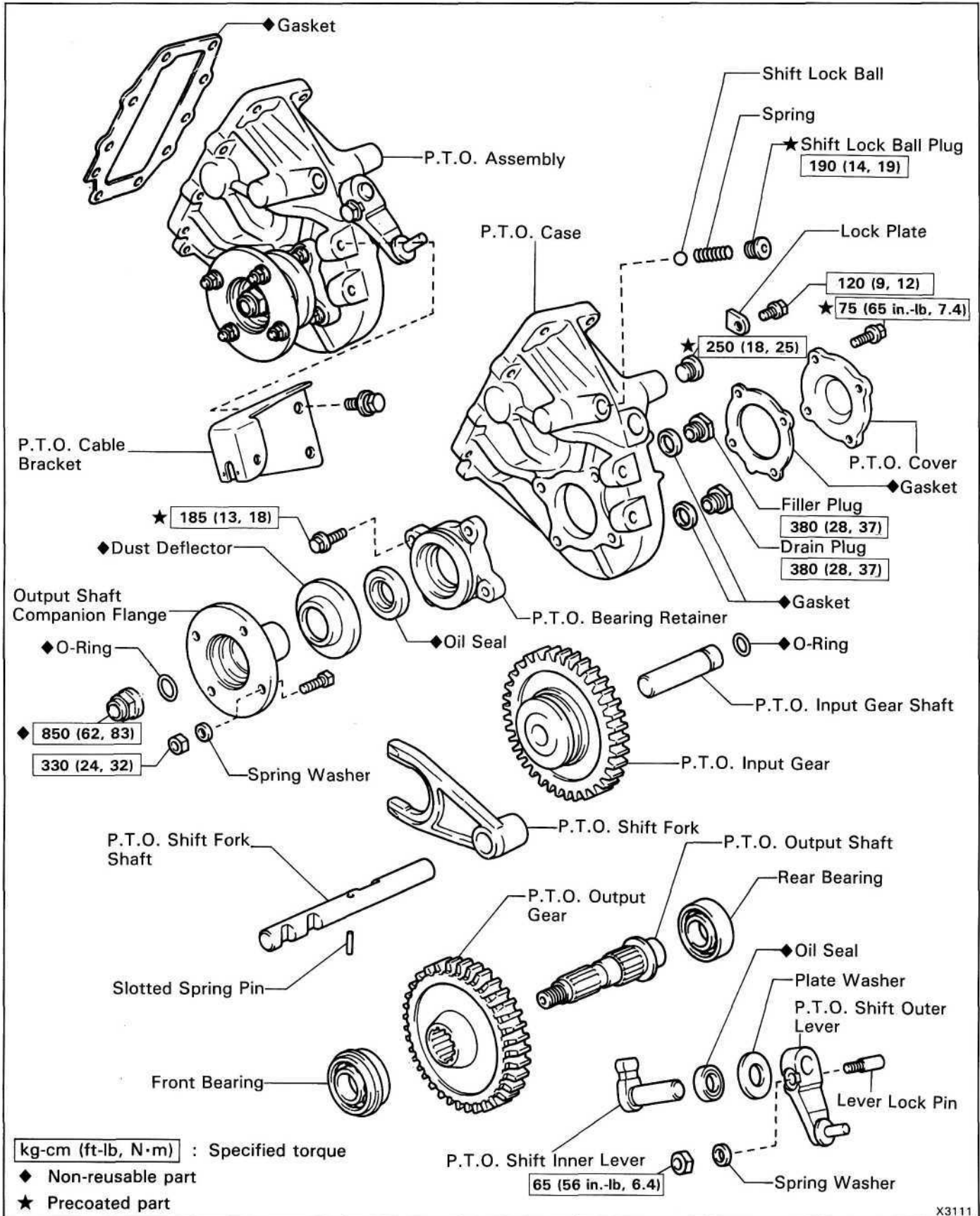

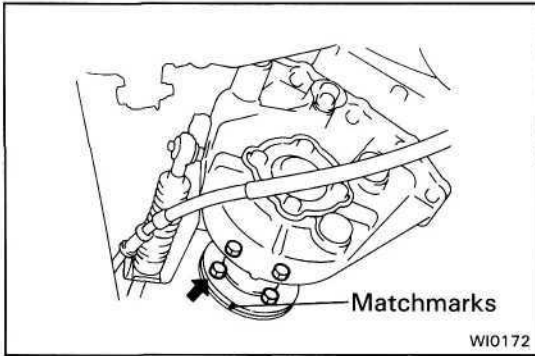

## REMOVAL OF P.T.O.

(See page WI-2)

1. **DRAIN P.T.O. OIL**
2. **DISCONNECT P.T.O. DRIVE SHAFT**
  - (a) Place matchmarks on the universal joint of the drive shaft and the P.T.O. companion flange.
  - (b) Remove the four bolts, washers and nuts.
3. **DISCONNECT P.T.O. SHIFT CABLE**
  - (a) Using pliers, remove the cotter pin of the shift cable.
  - (b) Remove the two bolts and the cable bracket.
4. **DISCONNECT SPEEDOMETER CABLE**

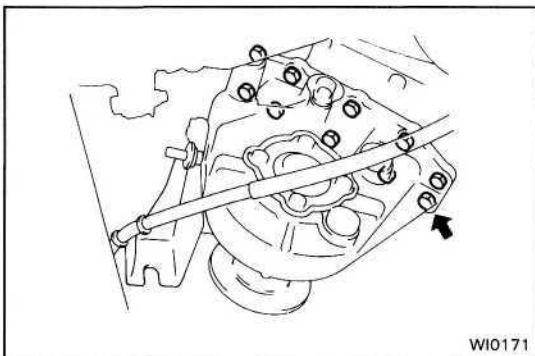
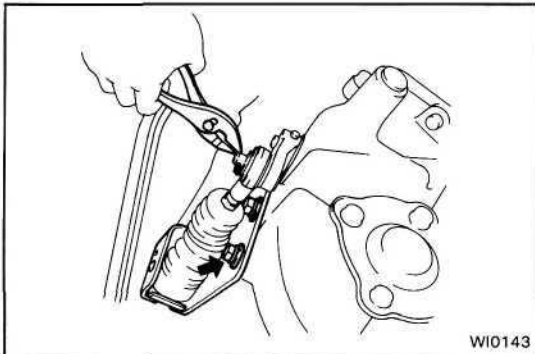

## 5. REMOVE P.T.O.

Remove the ten bolts, the P.T.O. and the gasket.

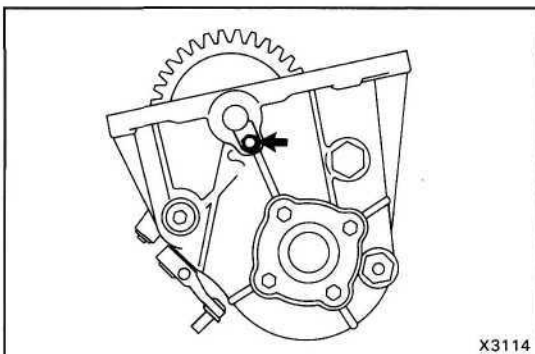

## DISASSEMBLY OF P.T.O.

(See page WI-2)

1. **REMOVE P.T.O. INPUT GEAR**
  - (a) Remove the bolt and the lock plate.
  - (b) Using a screwdriver, remove the input gear shaft and the input gear.
  - (c) Remove the O-ring.

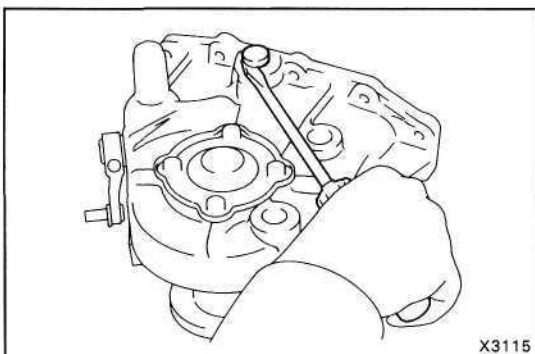

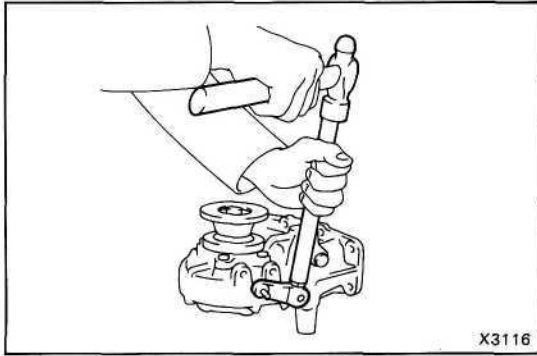

## 2. REMOVE P.T.O. SHIFT OUTER LEVER AND SHIFT INNER LEVER

- (a) Remove the nut and the washer.
- (b) Using a brass bar and a hammer, tap out the lever lock pin.
- (c) Remove the shift outer lever, plate washer and shift inner lever.

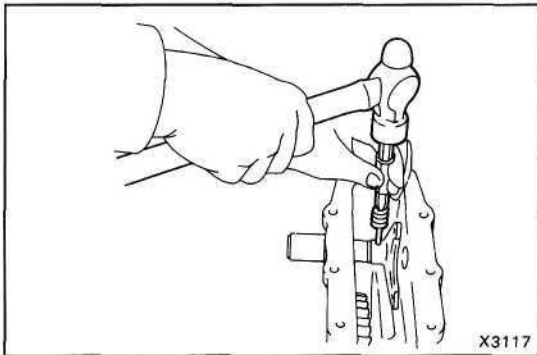

## 3. REMOVE P.T.O. SHIFT FORK

- (a) Drive out the slotted spring pin with a pin punch.
- (b) Using a torx socket wrench, remove the shift lock ball plug.  
**(Torx socket wrench T40 09042-00020)**
- (c) Remove the spring and the shift lock ball.

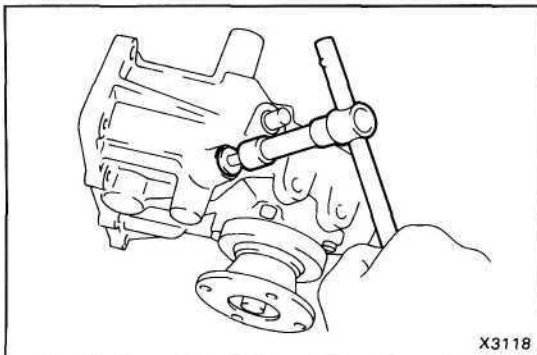

- (d) Using a hexagon wrench, remove the shift fork shaft plug, the shift fork shaft and the shift fork.

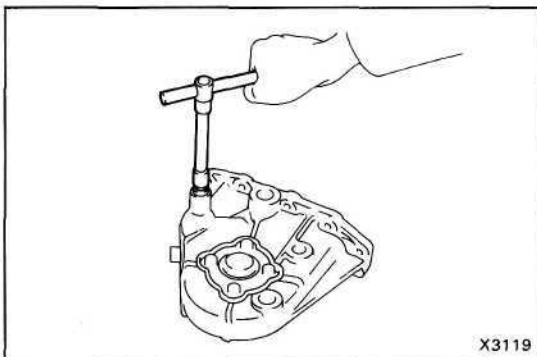

## 4. REMOVE COMPANION FLANGE

- (a) Using a chisel, loosen the staked part of the nut.



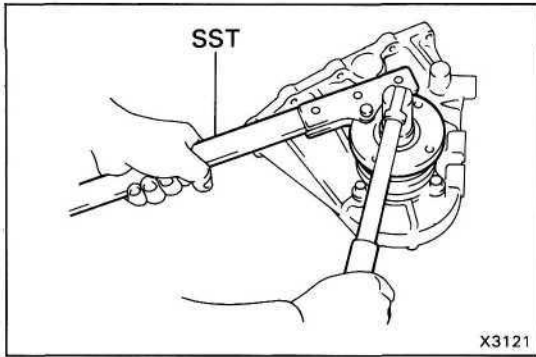

(b) Using SST to hold the flange, remove the nut and the O-ring.

SST 09330-00021

(c) Remove the flange.

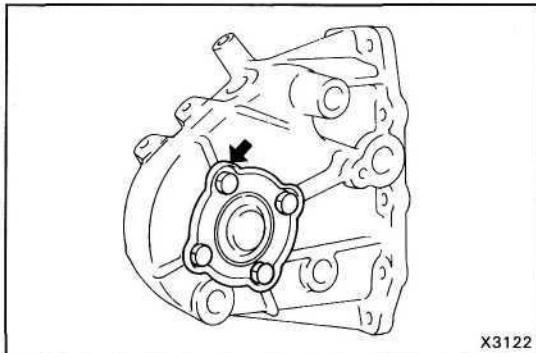

#### 5. REMOVE P.T.O. COVER

Remove the four bolts, the cover and gasket.

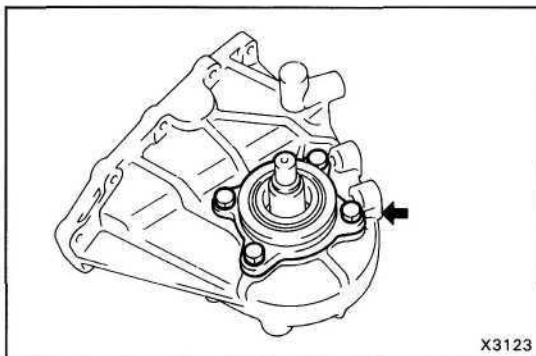

#### 6. REMOVE P.T.O. BEARING RETAINER

Remove the four bolts and the bearing retainer.

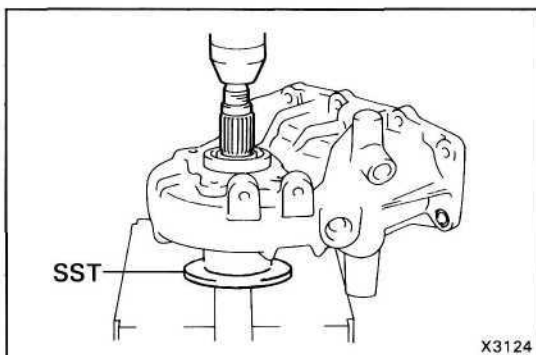

#### 7. REMOVE P.T.O. OUTPUT GEAR

Using SST and a press, remove the front bearing, output gear and output shaft.

SST 09316-20011

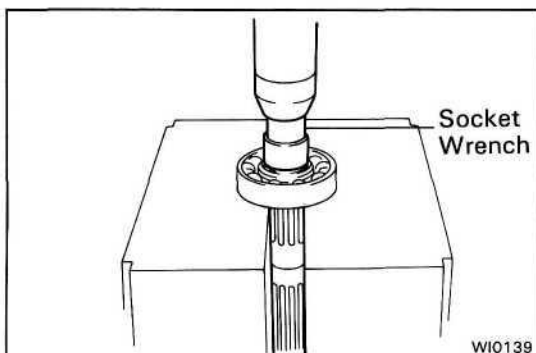

#### 8. REMOVE REAR BEARING

Using a socket wrench and a press, remove the rear bearing.

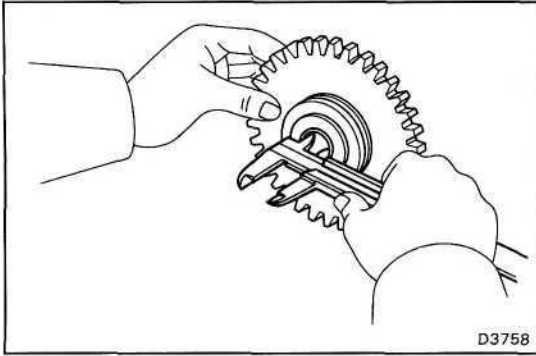

## INSPECTION AND REPLACEMENT OF P.T.O. COMPONENTS

### 1. INSPECT P.T.O. GEAR BUSHING

Using calipers, measure the P.T.O. gear bushing bore.

**Standard bore: 20.04 - 20.08 mm  
(0.7890 - 0.7906 in.)**

**Maximum bore: 20.08 mm (0.7906 in.)**

If the bushing bore is greater than the maximum, replace the input gear assembly.

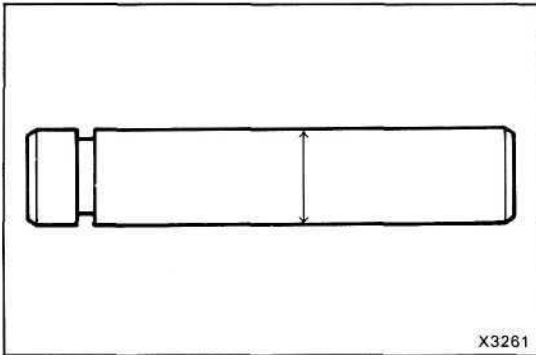

### 2. INSPECT INPUT GEAR SHAFT

Inspect input gear shaft for wear or damage. If damaged, replace the input gear shaft.

Using calipers, measure the diameter of the input gear shaft.

**Standard outer diameter: 19.987 — 20.000 mm  
(0.7869 - 0.7874 in.)**

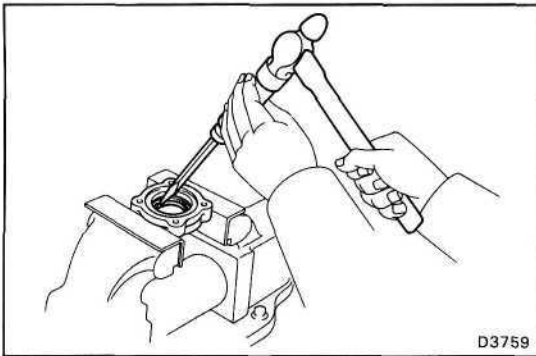

### 3. REPLACE BEARING RETAINER OIL SEAL

(a) Inspect a crack, wear or damage.

(b) Using a screwdriver, drive out the oil seal.

(c) Using SST, drive in a new oil seal.

SST 09608-35014 (09608-06020, 09608-06100)

(d) Coat the lip of the oil seal with MP grease.

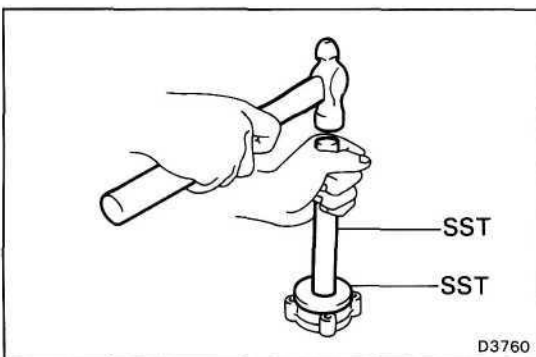

### 4. REPLACE SHIFT INNER LEVER OIL SEAL

(a) Inspect a crack, wear or damage.

(b) Using a screwdriver, pry out the oil seal.

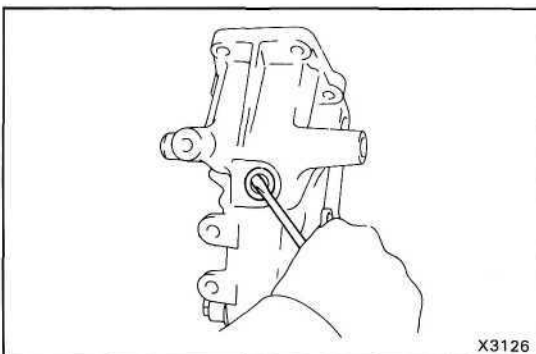

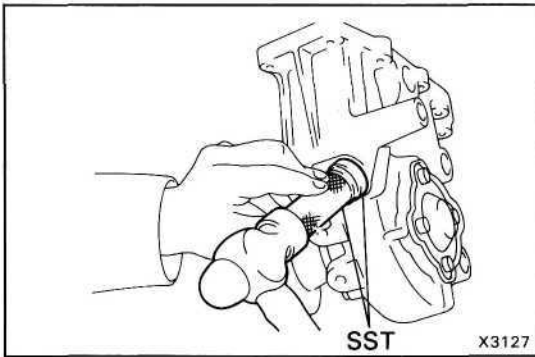

- (c) Using SST, drive in a new oil seal.
- SST 09550-10012 (09252-10010, 09633-12010)
- (d) Coat the lip of the oil seal with MP grease.

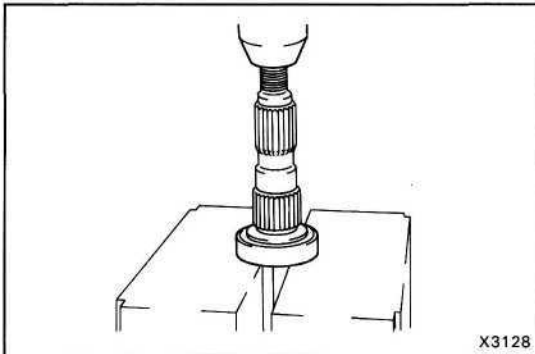

## ASSEMBLY OF P.T.O.

(See page WI-2)

### 1. INSTALL REAR BEARING

Using a press, install the rear bearing to the output shaft.

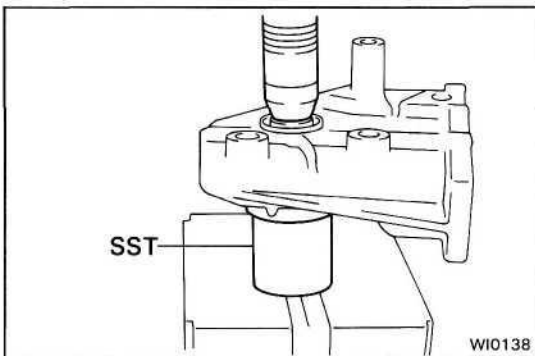

### 2. INSTALL P.T.O. OUTPUT GEAR

Using SST and a press, install the output gear and the front bearing.

SST 09515-30010

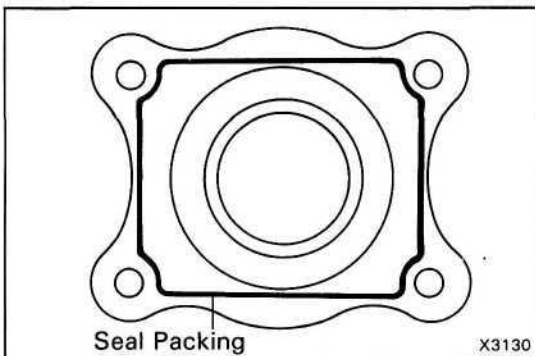

### 3. INSTALL P.T.O. BEARING RETAINER

(a) Using a scraper and a wire brush, clean down the retainer and the case.

(b) Apply seal packing to the P.T.O. case as shown.

**Seal packing: Part No. 08826-00090, THREE BOND 1281 or equivalent**

**HINT:** Install the bearing retainer as soon as seal packing is applied.

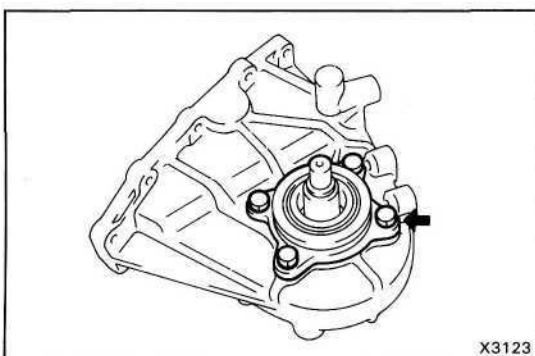

(c) Apply liquid sealer to the threads of four bolts.

**Sealant: Part No. 08833-00080, THREE BOND 1344, LOCTITE 242 or equivalent**

(d) Torque the four bolts.

**Torque: 185 kg-cm (13 ft-lb, 18 N-m)**

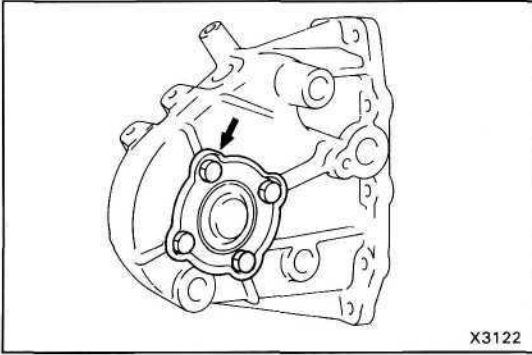

#### 4. INSTALL P.T.O. COVER

- (a) Apply liquid sealer to the threads of four bolts.

**Sealant:** Part No. 08833-00080, THREE BOND 1344, LOCTITE 242 or equivalent

- (b) Install the cover with a new gasket and torque the four bolts.

**Torque:** 75 kg-cm (65 in.-lb, 7.4 N-m)

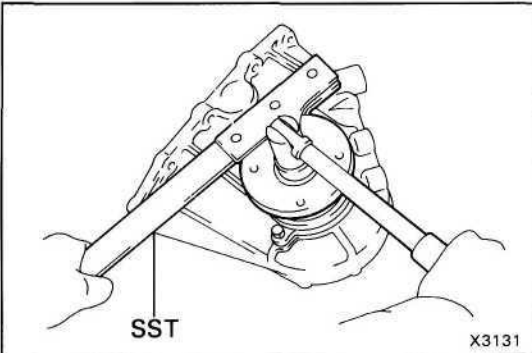

#### 5. INSTALL COMPANION FLANGE

- (a) Install the flange and new O-ring.

- (b) Using SST to hold the flange, install a new nut.

SST 09330-00021

**Torque:** 850 kg-cm (62 ft-lb, 83 N-m)

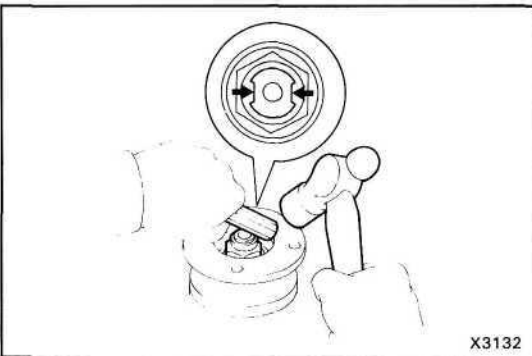

- (c) Using a chisel, stake the nut.

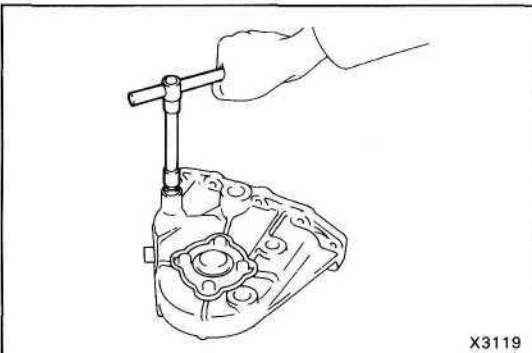

#### 6. INSTALL P.T.O. SHIFT FORK

- (a) Install the shift fork to the case, then install the shift fork shaft to the shift fork.

HINT: Install in proper direction only.

- (b) Apply liquid sealer to the threads of the shift fork shaft plug.

**Sealant:** Part No. 08833-00080, THREE BOND 1344, LOCTITE 242 or equivalent

- (c) Using a hexagon wrench, tighten shift fork shaft plug.

**Torque:** 250 kg-cm (18 ft-lb, 25 N-m)

- (d) Install the lock ball and the spring.

- (e) Apply liquid sealer to the threads of lock ball plug.

**Sealant:** Part No. 08833-00080, THREE BOND 1344, LOCTITE 242 or equivalent



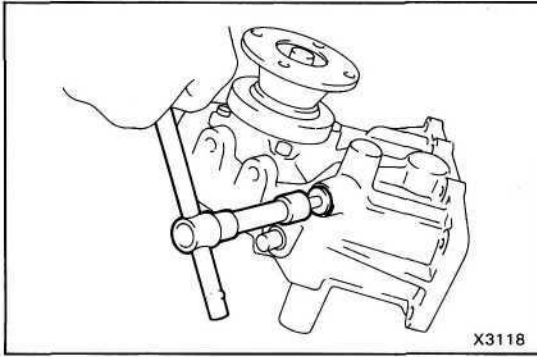

- (f) Using a torx socket wrench, torque the lock ball plug.  
(Torx socket wrench T40 09042-00020)

**Torque: 190 kg-cm (14 ft-lb, 19 N-m)**

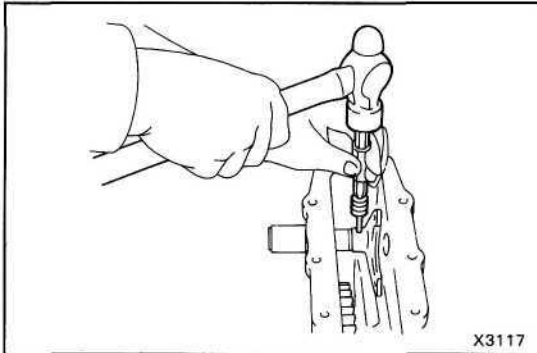

- (g) Using a pin punch, drive in the slotted spring pin.

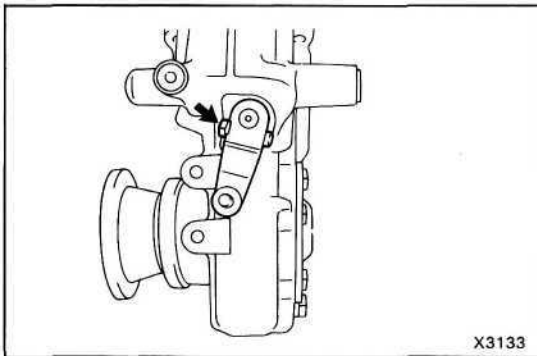

#### 7. INSTALL P.T.O. SHIFT OUTER LEVER AND SHIFT INNER LEVER

- (a) Install the shift inner lever, plate washer and shift outer lever.

- (b) Tighten the lever lock pin, washer and nut.

**Torque: 65 kg-cm (56 in.-lb, 6.4 N-m)**

**HINT:** Install in proper direction only.

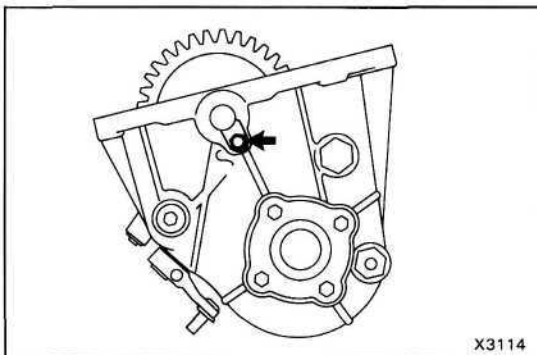

#### 8. INSTALL P.T.O. INPUT GEAR

- (a) Install O-ring to the input gear shaft.

- (b) Coat MP grease.

- (c) Align the shift fork with the groove of the input gear and insert the input gear shaft.

**HINT:** Be careful not to damage O-ring.

- (d) Install the lock plate and torque the bolt.

**Torque: 120 kg-cm (9 ft-lb, 12 N-m)**

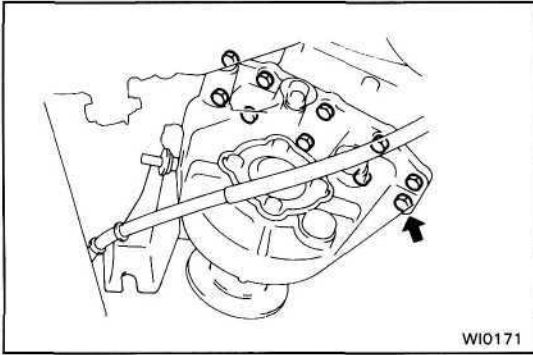

WI0171

## INSTALLATION OF P.T.O.

(See page WI-2)

### 1. INSTALL P.T.O. ASSEMBLY

- (a) Apply liquid sealer to the threads of the ten bolts.

**Sealant: Part No. 08833-00080, THREE BOND 1344, LOCTITE 242 or equivalent**

- (b) Insert P.T.O. assembly with a new gasket and torque the ten bolts.

**Torque: 185 kg-cm (13 ft-lb, 18 N-m)**

### 2. CONNECT P.T.O. SHIFT CABLE

- (a) Install the cable bracket and the two bolts.

- (b) Using pliers, install the cotter pin of the shift cable.

### 3. INSTALL SPEEDOMETER CABLE

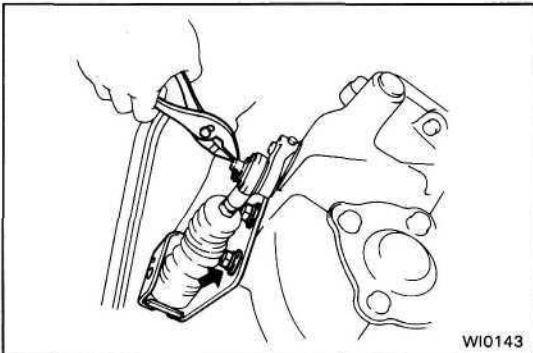

WI0143

### 4. INSTALL P.T.O. DRIVE SHAFT

- Align the matchmarks, and install the four bolts, washers and nuts.

**Torque: 330 kg-cm (24 ft-lb, 32 N-m)**

### 5. INSTALL DRAIN PLUG

- (a) Install a new gasket and the drain plug.

- (b) Torque the drain plug.

**Torque: 380 kg-cm (28 ft-lb, 37 N-m)**

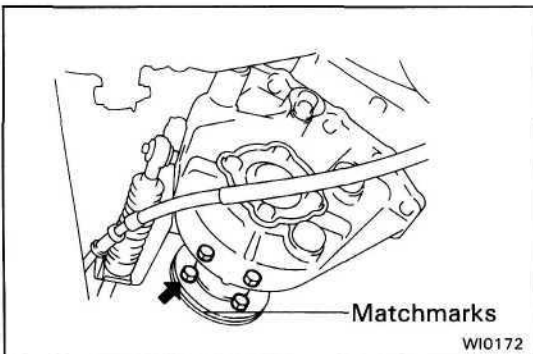

WI0172

### 6. FILL P.T.O WITH TRANSMISSION OIL

- (a) Fill the P.T.O. with transmission oil.

- (b) Install a new gasket and the filler plug.

- (c) Torque the filler plug.

**Torque: 380 kg-cm (28 ft-lb, 37 N-m)**

**Oil grade: API GL-4 or GL-5**

**SAE 75W-90**

**Capacity: 0.1 liter (0.1 US qts, 0.09 Imp.qts)**

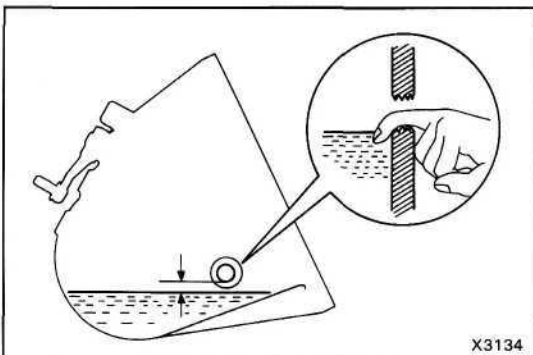

X3134

## Drive Shaft COMPONENTS

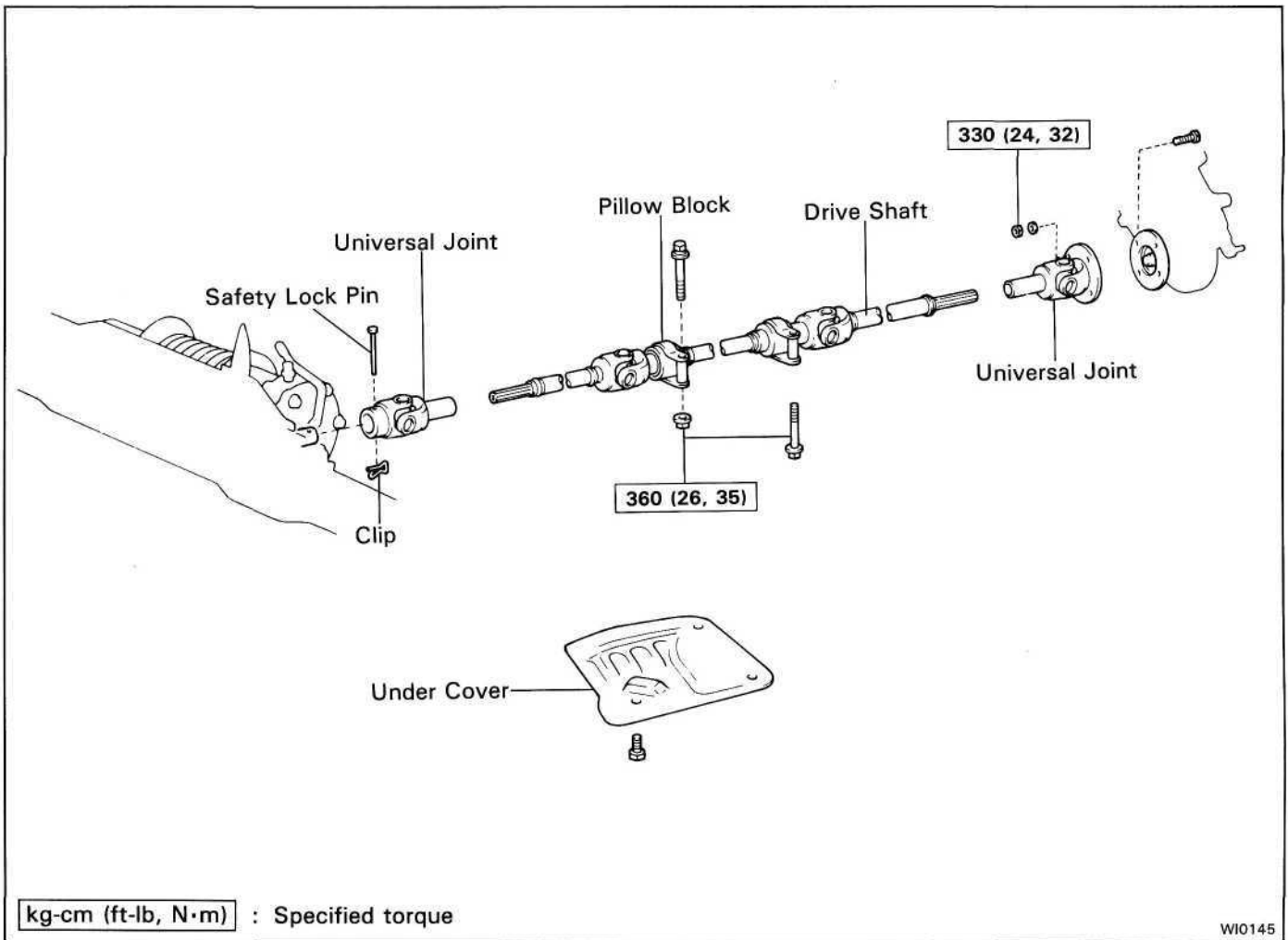

WI0145

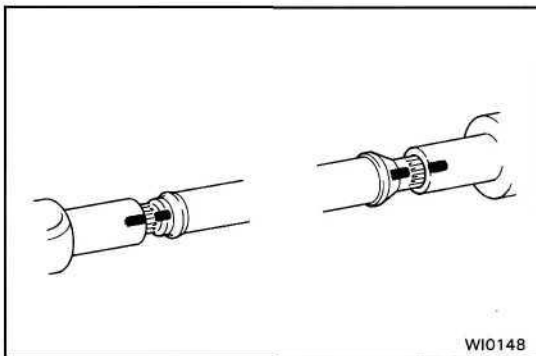

WI0148

### REMOVAL OF DRIVE SHAFT

1. REMOVE ENGINE UNDER COVER
2. REMOVE TRANSMISSION UNDER COVER
3. PLACE MATCHMARKS
  - (a) Place the matchmarks on the universal joint and the drive shaft.
  - (b) Place the matchmarks on the universal joint and the companion flange.

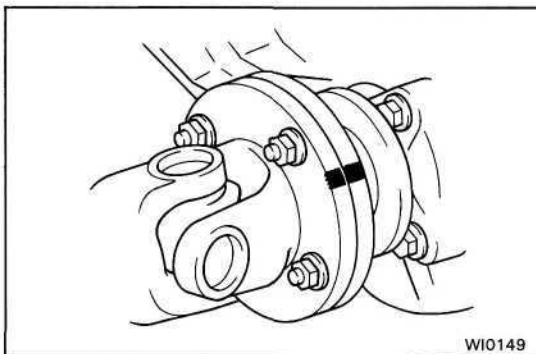

WI0149

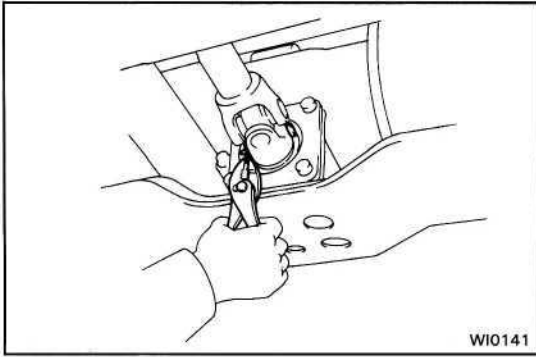

WI0141

#### 4. REMOVE SAFETY LOCK PIN

Using pliers, remove the clip and safety lock pin.

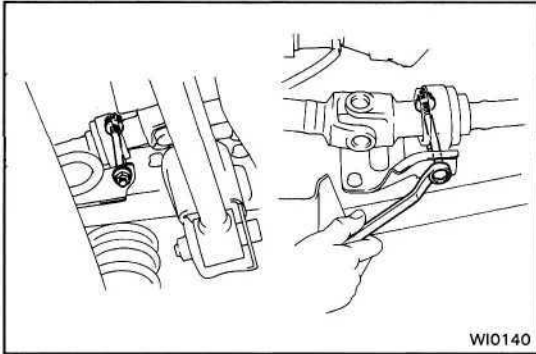

WI0140

#### 5. DISCONNECT DRIVE SHAFT

(a) Remove the pillow block set bolts and the nut.

(b) Remove the P.T.O. companion flange set bolts and nuts, then disconnect the drive shaft assembly.

HINT: Do not forcefully remove the universal joint.

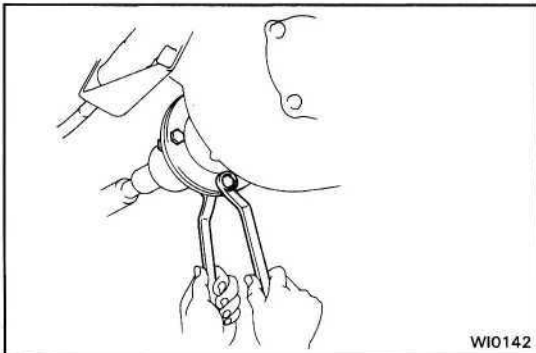

WI0142

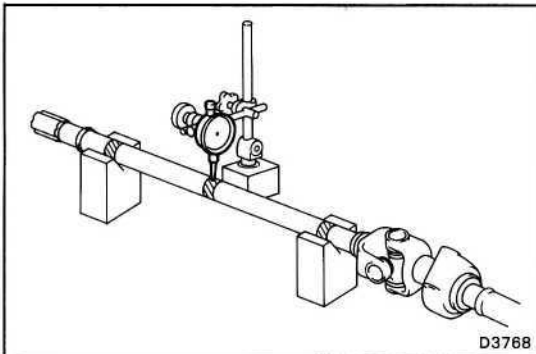

D3768

### INSPECTION OF DRIVE SHAFT COMPONENTS

#### 1. INSPECT DRIVE SHAFT FOR DAMAGE OR RUNOUT

**Maximum runout: 0.7 mm (0.028 in.)**

If the shaft runout is greater than the maximum, replace the shaft.

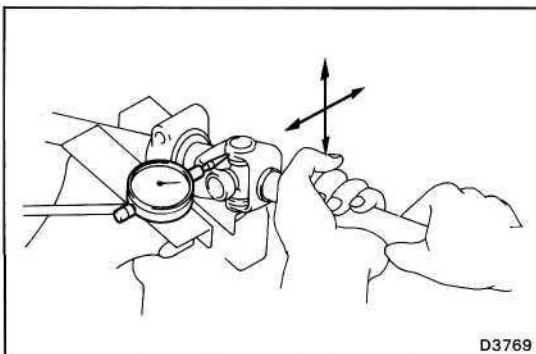

D3769

#### 2. INSPECT SPIDER BEARINGS

(a) Inspect the spider bearings for wear or damage.

(b) Check the spider bearing axial play.

**Bearing axial play: 0.15 mm (0.0059 in.)**

If necessary, replace the spider bearing.

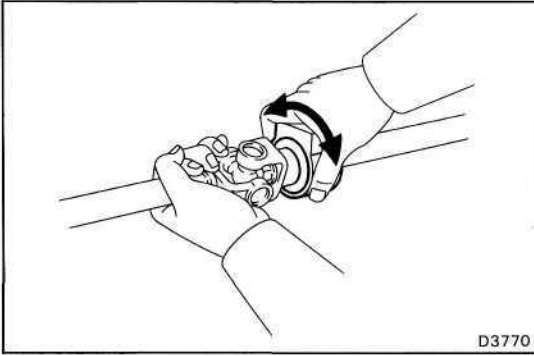

D3770

### 3. INSPECT PILLOW BLOCK BEARING

Check that the bearing turns freely.

If the bearing is damaged, worm or does not turn freely, replace it.

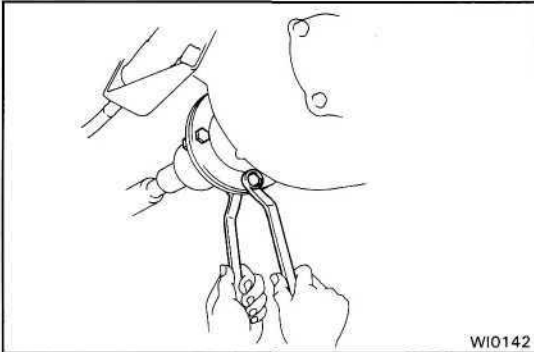

WI0142

## INSTALLATION OF DRIVE SHAFT

(See page WI-11)

### 1. INSTALL DRIVE SHAFT

(a) Align the matchmarks.  
(See page WI-11)

(b) Install and torque the bolts and the nut.

**Torque: 330 kg-cm (24 ft-lb, 32 N-m)**

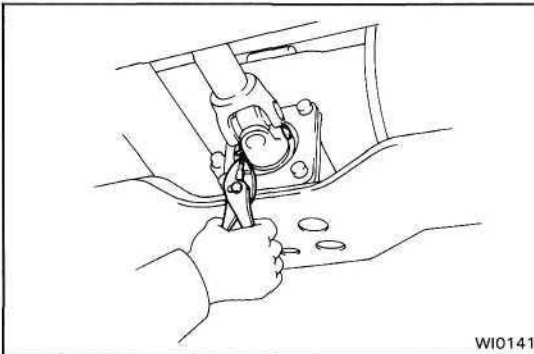

WI0141

### 2. INSTALL SAFETY LOCK PIN

(a) Align the safety lock pin hole of the universal joint and worm.

(b) Install the safety lock pin and the clip.

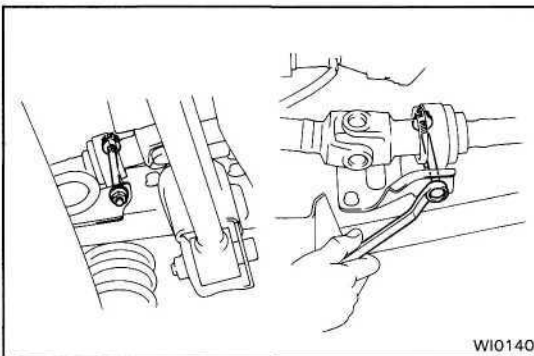

WI0140

### 3. INSTALL PILLOW BLOCK

Install the pillow blocks with bolts and nuts.

**Torque: 360 kg-cm (26 ft-lb, 35 N-m)**

### 4. INSTALL ENGINE UNDER COVER

### 5. INSTALL TRANSMISSION UNDER COVER

# Winch Assembly

## REMOVAL AND INSTALLATION OF WINCH ASSEMBLY

Remove and install the parts as shown.

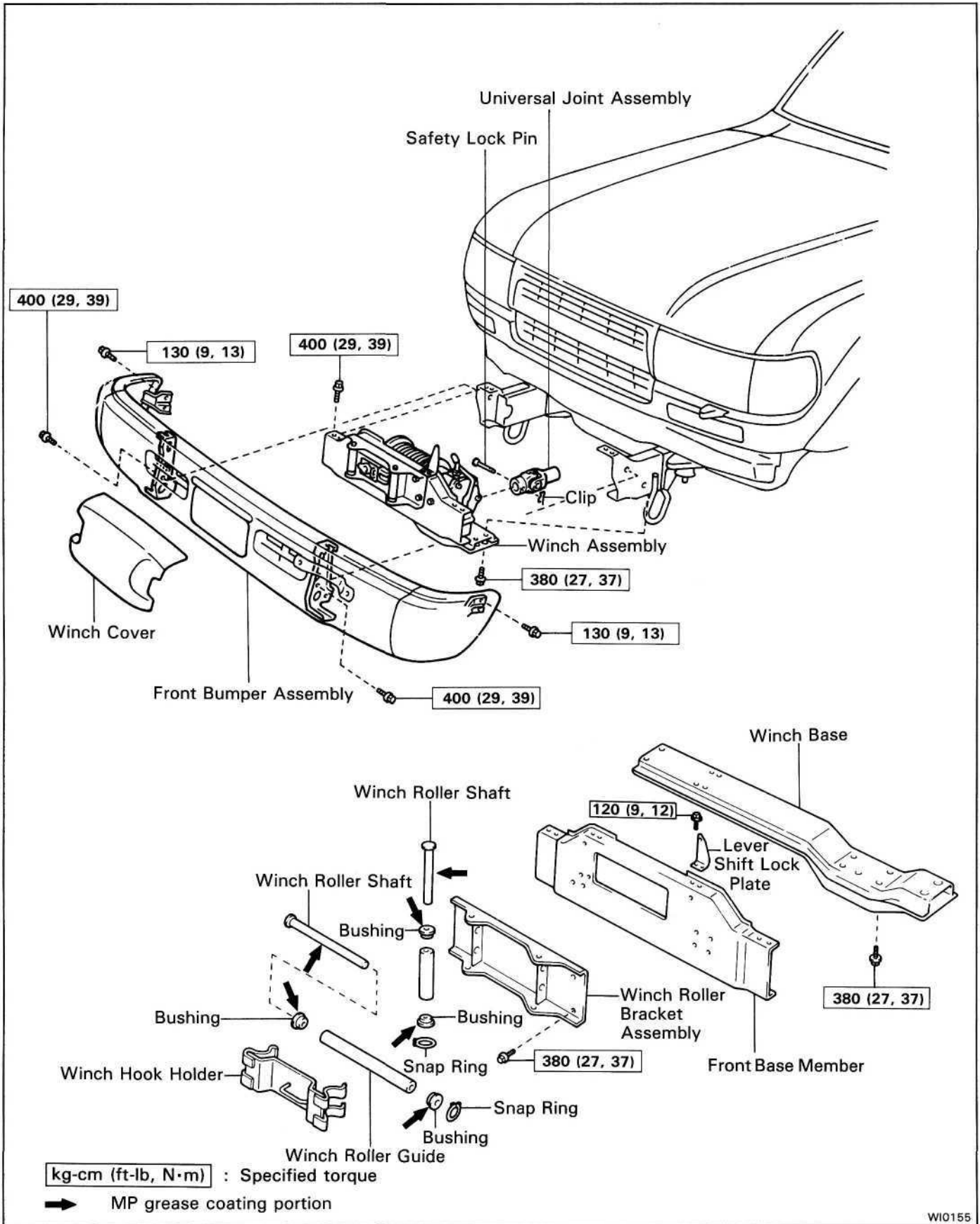

COMPONENTS

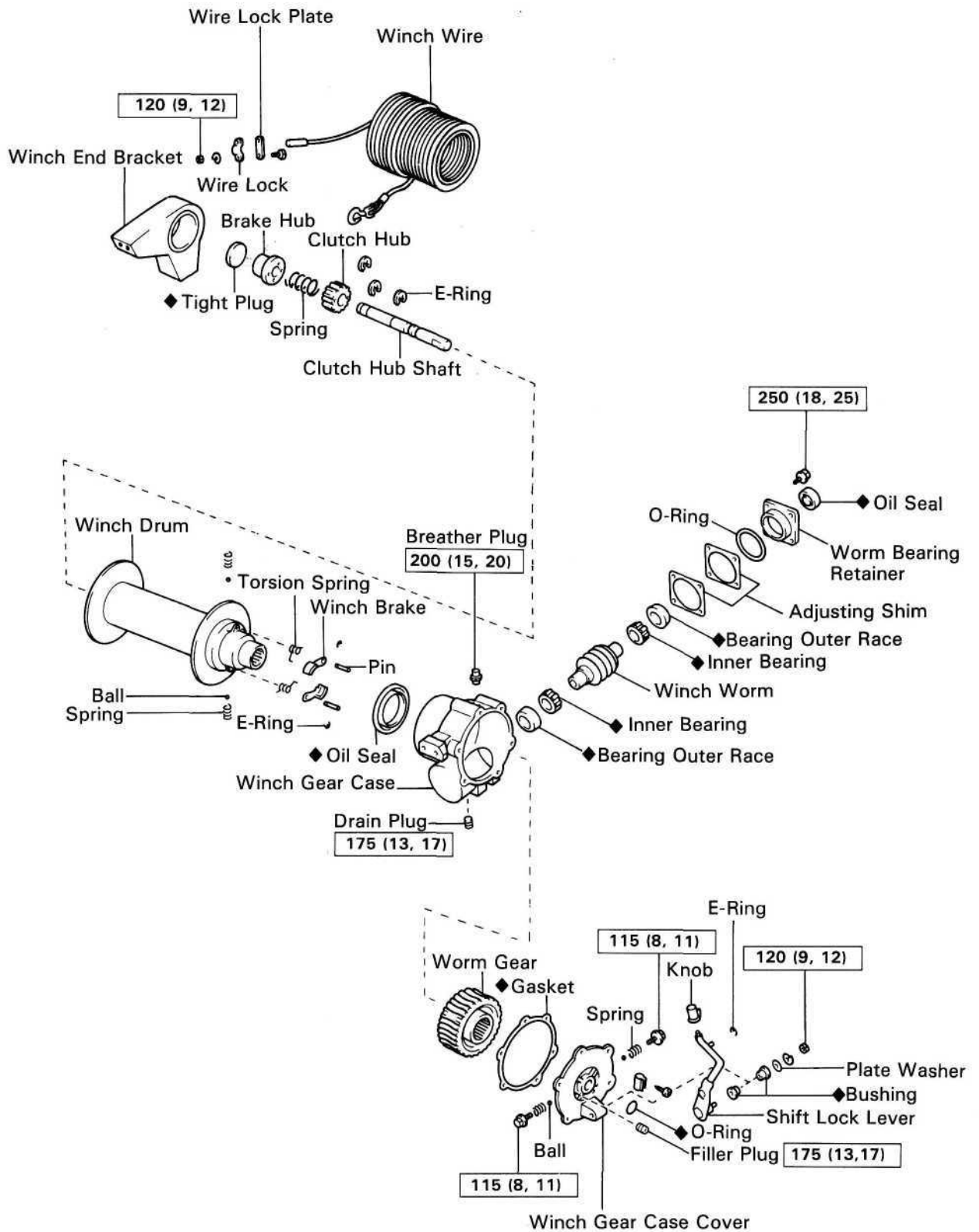

kg-cm (ft-lb, N·m) : Specified torque

◆ Non-reusable part

**DISASSEMBLY OF WINCH ASSEMBLY**

(See page WI-15)

1. DRAIN WINCH FLUID
2. REMOVE WINCH END BRACKET

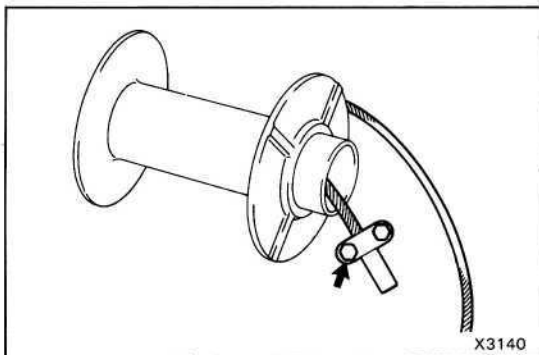
**3. REMOVE WINCH WIRE**

- (a) Remove the two bolts, spring washers and nuts.
- (b) Remove the wire lock and lock plate from the winch wire.

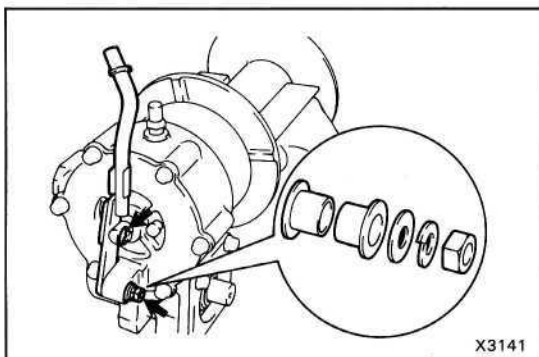
**4. REMOVE SHIFT LOCK LEVER**

- (a) Remove the nut, spring washer and plate washer.
- (b) Remove the E-ring and the shift lock lever.
- (c) Remove the two bushings from the shift lock lever.

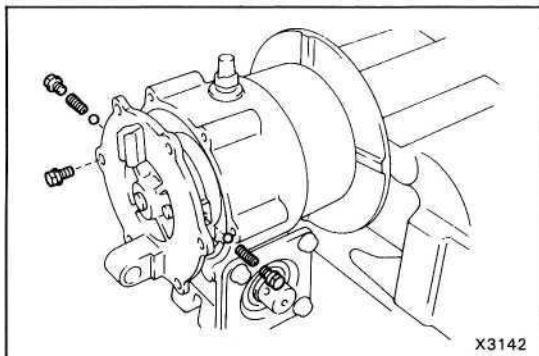
**5. REMOVE WINCH GEAR CASE COVER**

- (a) Remove the six bolts.
- (b) Tap the gear case cover with a plastic hammer.
- (c) Pull out the gear case cover until you can see the ball of clutch hub shaft and the bolt.
- (d) Remove the two bolts, the two balls and the two springs.
- (e) Remove the gear case cover and gasket.
- (f) Remove the O-ring from the gear case cover.

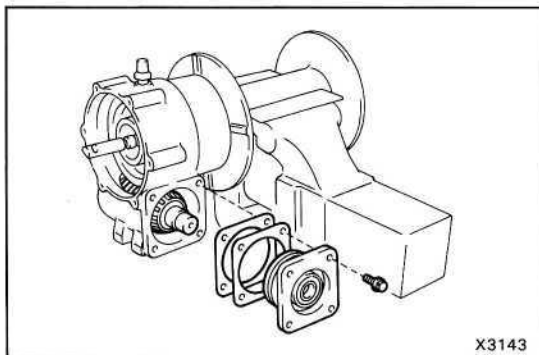
**6. REMOVE WINCH WORM**

- (a) Remove the four bolts.
- (b) Using a plastic hammer, remove the worm bearing retainer and the adjusting shims.
- (c) Remove the winch worm.
- (d) Remove the O-ring from the worm bearing retainer.

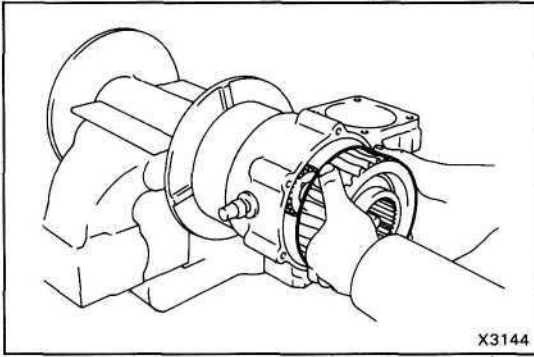
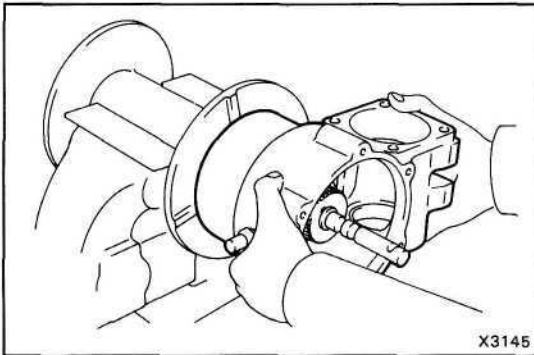
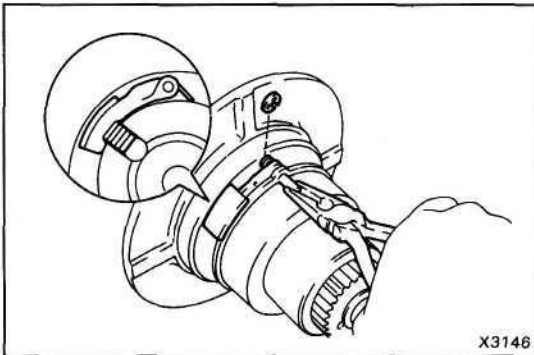

**7. REMOVE WORM GEAR****8. REMOVE WINCH GEAR CASE****9. REMOVE WINCH BRAKE**

- (a) Remove the two E-rings.
- (b) Pull out the two pins.
- (c) Remove the two torsion springs and the two winch brakes.
- (d) Remove the two springs and the two balls from the winch drum.

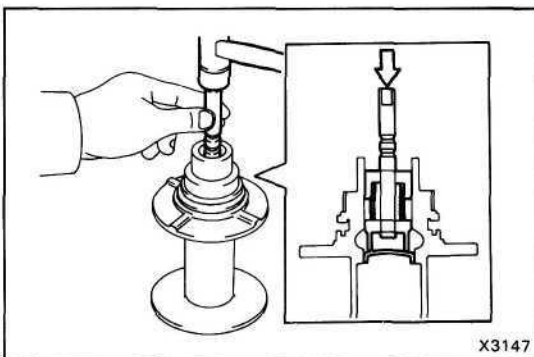
**10. REMOVE CLUTCH HUB SHAFT**

- (a) Using a plastic hammer, tap the top of the clutch hub shaft.
- (b) Remove the tight plug.
- (c) Pull out the clutch hub shaft from the winch drum.

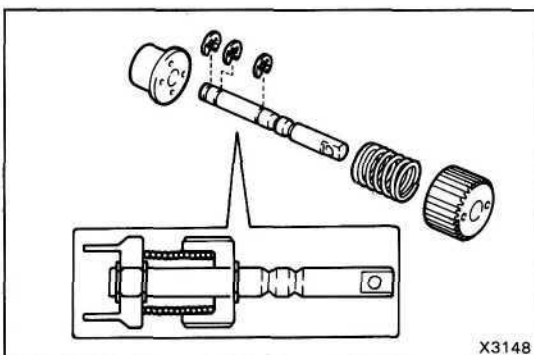

- (d) Remove the three E-rings.
- (e) Remove the clutch hub, the spring and the brake hub from the clutch hub shaft.

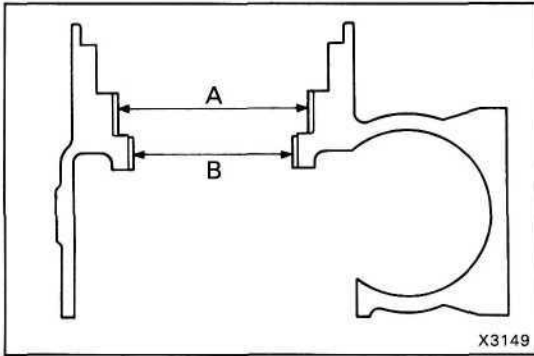

## INSPECTION AND REPLACEMENT OF WINCH ASSEMBLY

### 1. INSPECT GEAR CASE

Using a caliper gauge, measure the bushing bore.

**Standard bore :**

**A: 90.000 - 90.035 mm (3.5433 - 3.5447 in.)**

**B: 75.000 - 75.030 mm (2.9528 - 2.9539 in.)**

**Maximum bore :**

**A: 90.3 mm (3.555 in.)**

**B: 75.3 mm (2.965 in.)**

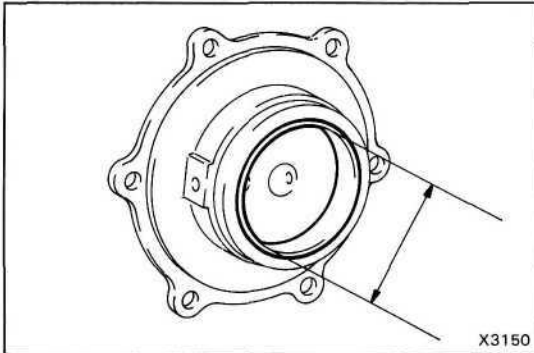

### 2. INSPECT WINCH GEAR CASE COVER

Using calipers, measure the bushing bore.

**Standard bore :**

**65.000 - 65.030 mm (2.5591 - 2.5602 in.)**

**Maximum bore :**

**65.3 mm (2.571 in.)**

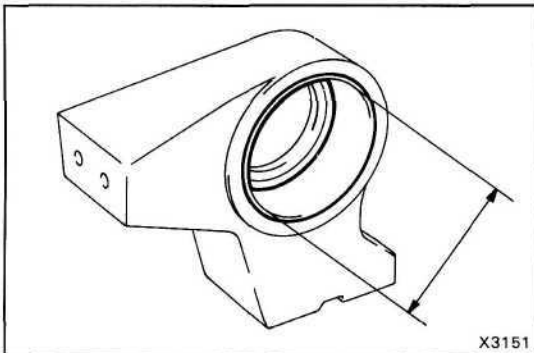

### 3. INSPECT WINCH END BRACKET

Using calipers, measure the bushing bore.

**Standard bore :**

**75.000 - 75.030 mm (2.9528 - 2.9539 in.)**

**Maximum bore :**

**75.2 mm (2.961 in.)**

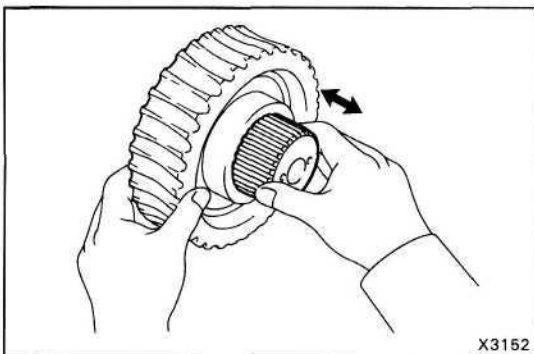

### 4. INSPECT WORM GEAR

(a) Inspect the worm gear for wear or damage.

(b) Install the clutch hub to the worm gear.

(c) Inspect that the clutch hub moves smoothly.

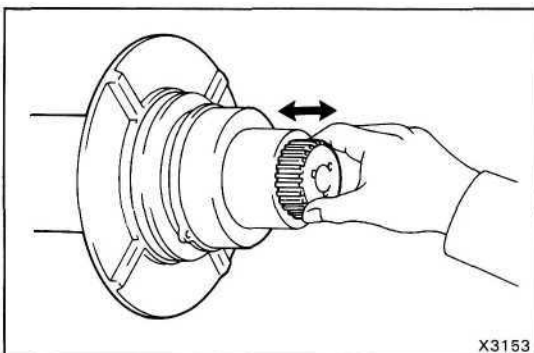

### 5. INSPECT WINCH DRUM AND CLUTCH HUB

(a) Install the clutch hub to the winch drum.

(b) Inspect that the clutch hub moves smoothly.

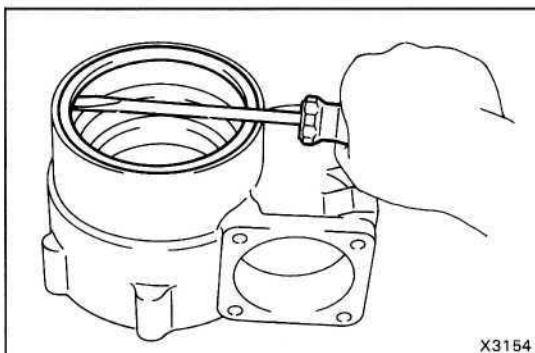
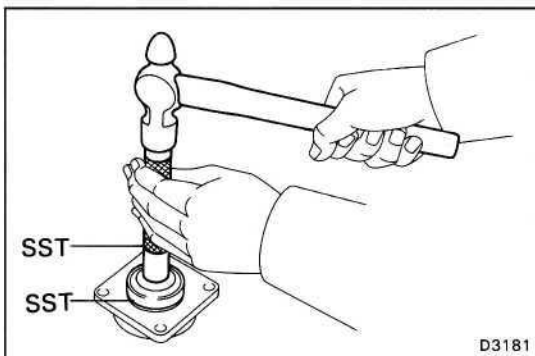
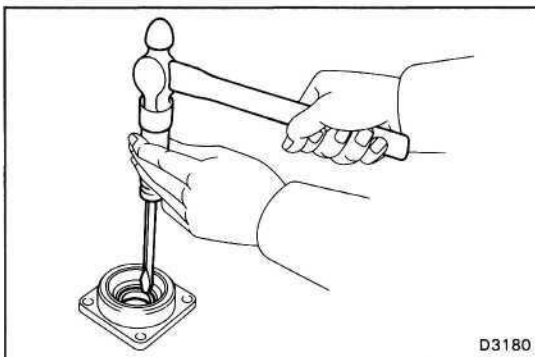
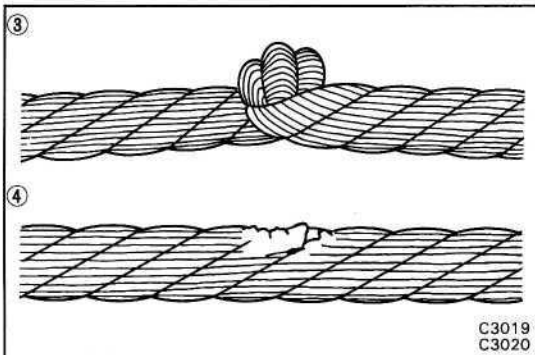
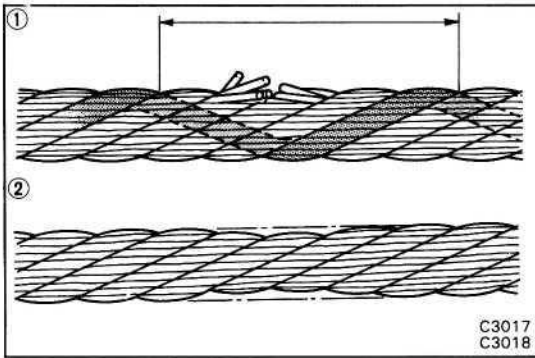

## 6. INSPECT WINCH WIRE

Inspect the winch wire for the following items. If damaged, replace the winch wire.

- More than 12 severed strands per wind.
- Wire diameter of less than 7.5 mm (0.295 in.)

- Kinks
- Corrosion
- Fraying

## 7. REPLACE WORM BEARING RETAINER OIL SEAL

- (a) Using a screwdriver, tap out the oil seal.

- (b) Using SST, install a new oil seal.

SST 09608-35014 (09608-06020, 09608-06090)

## 8. REPLACE WINCH GEAR CASE OIL SEAL

- (a) Using a screwdriver, pry off the oil seal.

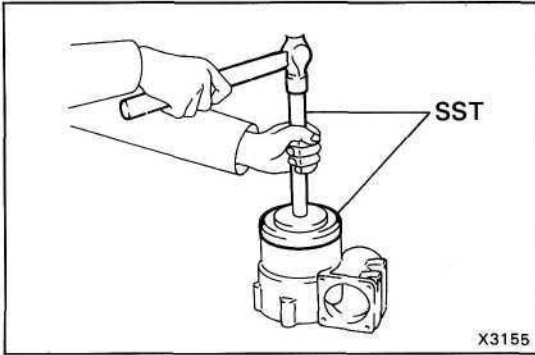

- (b) Using SST, install a new oil seal.  
SST 09550-55010 (09550-05020, 09550-05070)

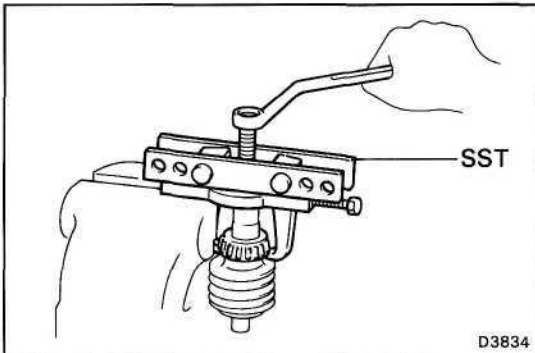

### 9. REPLACE WORM BEARING

- (a) Using SST, remove the inner bearing.  
SST 09950-20017

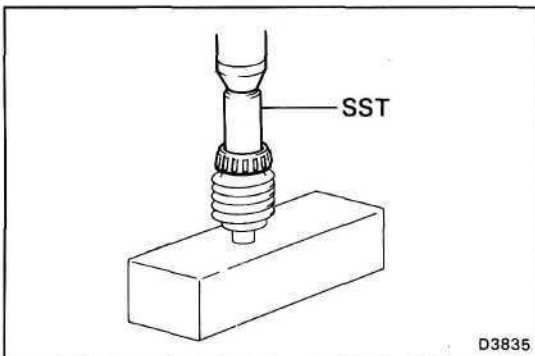

- (b) Using a press and SST, press in a new inner bearing.  
SST 09632-36010

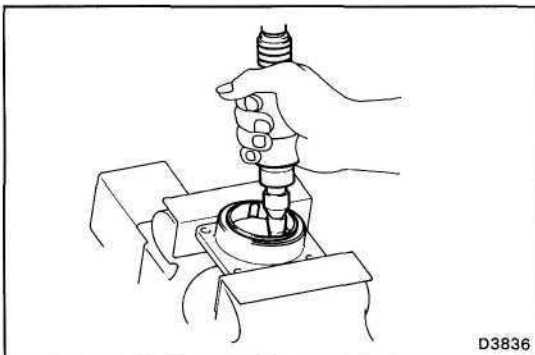

- (c) Using a little air grinder, grind the bearing outer race  
(worm bearing retainer side).  
HINT: Be careful not to damage the bearing retainer.

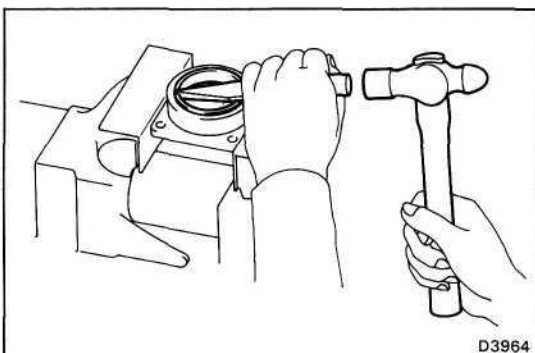

- (d) Using a chisel and hammer, remove the bearing outer race  
(worm bearing retainer side).  
HINT: Be careful not to damage the bearing retainer.

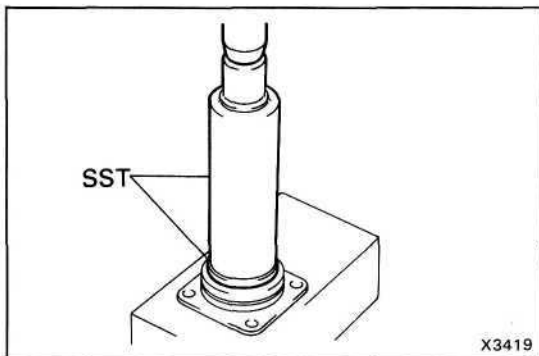

- (e) Using SST and a press, press in a new outer race (worm bearing retainer side).

SST 09316-60010 (09316-00010, 09316-00070)

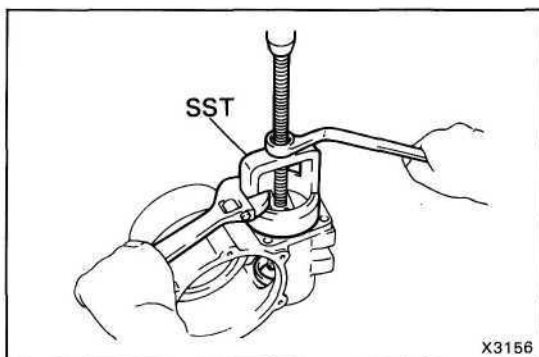

- (f) Using SST, remove the bearing outer race (gear case side).

SST 09612-65014 (09612-01030, 09612-01050)

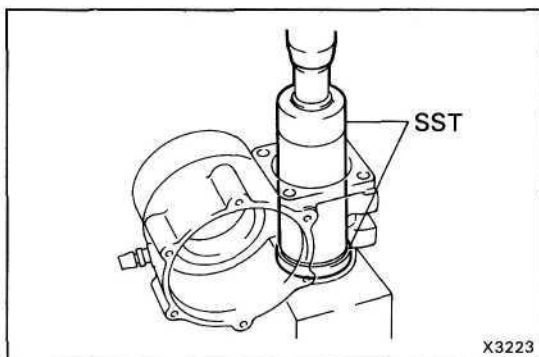

- (g) Using SST and a press, press in a new outer race (gear case side).

SST 09316-60010 (09316-00010, 09316-00070)

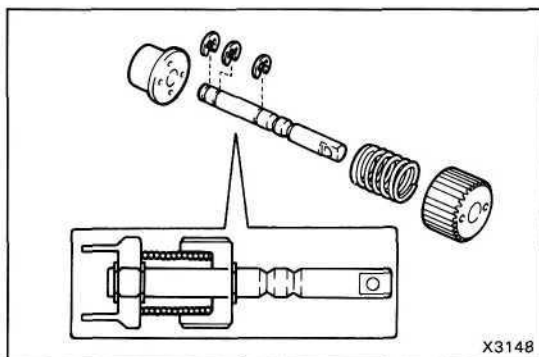

## ASSEMBLY OF WINCH ASSEMBLY

(See page WI-15)

### 1. INSTALL CLUTCH HUB SHAFT

- (a) Install the clutch hub, the spring and the brake hub to the clutch hub shaft with the three E-rings.

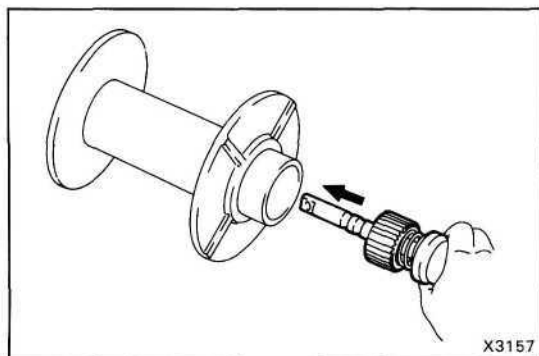

- (b) Insert the clutch hub shaft into the winch drum from the winch end bracket side.

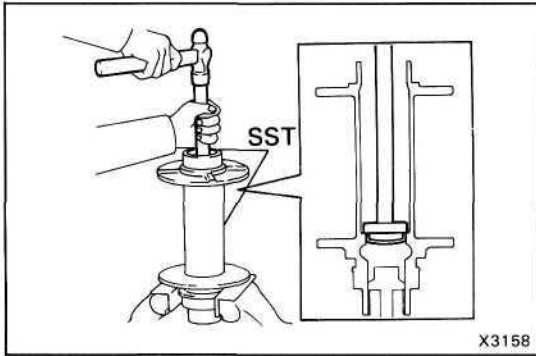

(c) Apply liquid sealer to a new tight plug.

**Sealant: Part No. 08833-00070, THREE BOND 1324 or equivalent**

(d) Using SST, install the tight plug.

SST 09608-35014 (09608-06100), 09631-12020

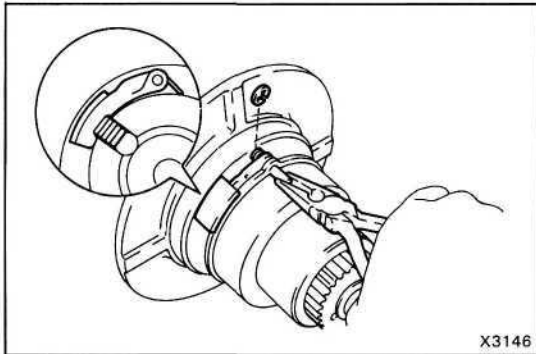

## 2. INSTALL WINCH BRAKE

(a) Install the two balls and the two springs to the winch drum.

(b) Align the spring with the notch of the winch brake, then install the two torsion springs and the two pins.

(c) Install the two E-rings.

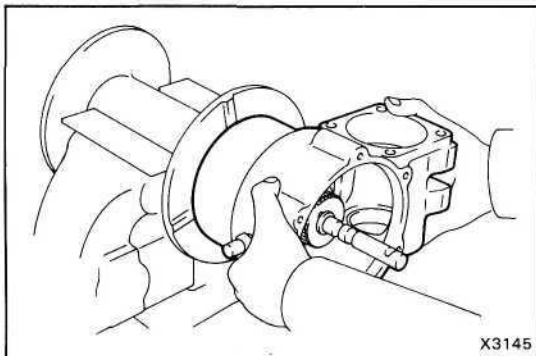

## 3. INSTALL WINCH GEAR CASE

Install the winch gear case to the winch drum.

HINT: Be careful not to damage the oil seal lip.

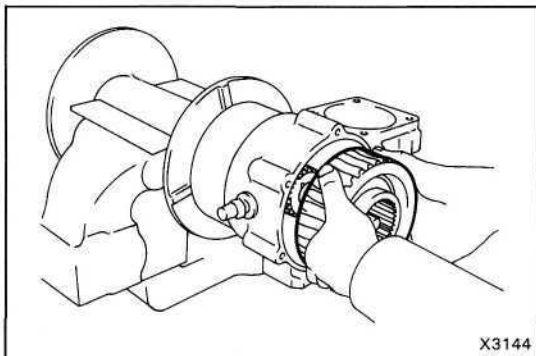

## 4. INSTALL WORM GEAR

Install the worm gear to the winch drum.

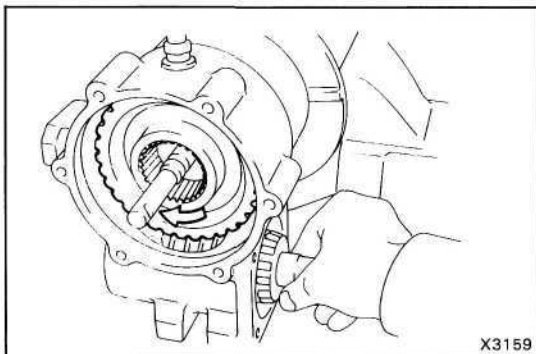

## 5. INSTALL WINCH WORM

(a) Install the winch worm to the worm gear.

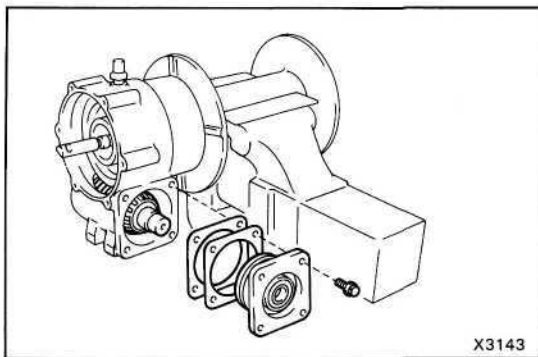

- (b) Install a new O-ring to the worm bearing retainer.
- (c) Install the adjusting shims and the worm bearing retainer with the four bolts. Torque the four bolts.

**Torque: 250 kg-cm (18 ft-lb, 25 N-m)**

**HINT:** Be careful not to damage the O-ring.

- (d) Rocking the worm to and from, check for looseness or tightness.
- (e) If necessary, exchange the shims for the correct sized shims with reference to the table.

**Shim thickness: 0.228 mm (0.0090 in.)**  
**0.5 mm (0.020 in.)**  
**1.0 mm (0.039 in.)**

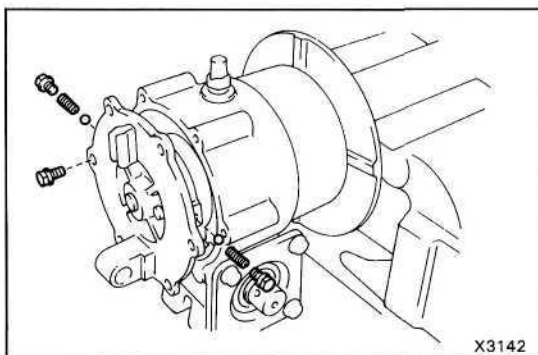

#### 6. INSTALL WINCH GEAR CASE COVER

- (a) Install a new O-ring to the gear case cover.
- (b) Install a new gasket to the gear case.
- (c) Insert the gear case cover about 30 mm (1.18 in.) in the clutch hub shaft and install two springs with two bolts.

**Torque: 115 kg-cm (8 ft-lb, 11 N-m)**

**HINT:** Be careful not to damage the O-ring.

- (d) Install the gear case cover with the six bolts.

**Torque: 120 kg-cm (9 ft-lb, 12 N-m)**

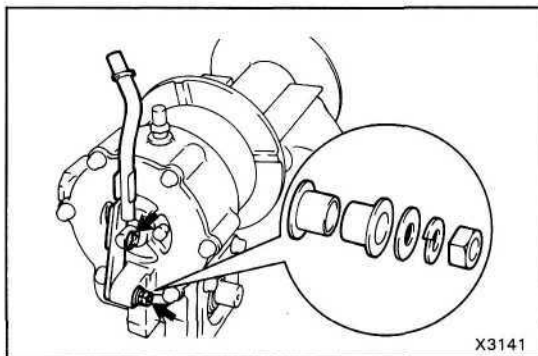

#### 7. INSTALL SHIFT LOCK LEVER

- (a) Install two bushings to the shift lock lever.
- (b) Install the E-ring, plate washer, spring washer and nut to the shift lock lever.

**Torque: 120 kg-cm (9 ft-lb, 12 N-m)**

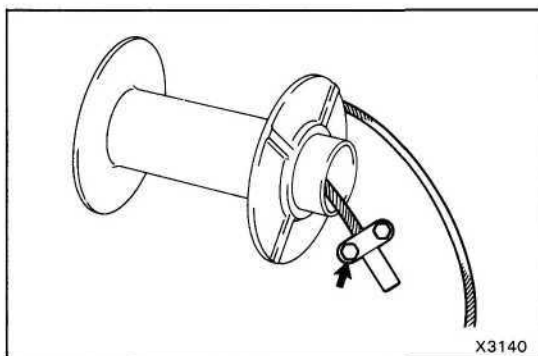

#### 8. INSTALL WINCH WIRE

- (a) Insert the winch wire into the wire installation hole of the drum and drum housing cover hole.
- (b) Install the wire lock and lock plate to the end of winch wire with the two bolts, two spring washers and the two nuts. Torque the bolts.

**Torque: 120 kg-cm (9 ft-lb, 12 N-m)**

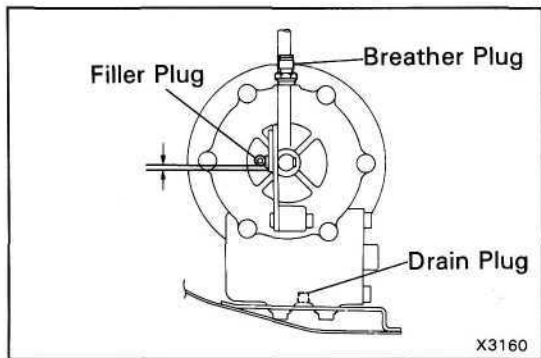
**9. INSTALL WINCH END BRACKET****10. FILL WINCH WITH GEAR OIL**

(a) Install the drain plug.

**Torque: 175 kg-cm (13 ft-lb, 17 N-m)**

(b) Remove the filler plug and the breather plug.

(c) Fill the winch with gear oil until the distance between the filler plug hole and fluid surface becomes less than 5 mm (0.2 in.)

**Oil grade: API GL-4**

**SAE 85W-90**

**Capacity: 0.3 liters (0.32 US qts, 0.26 Imp.qts)**

(d) Install the filler plug and torque it.

**Torque: 175 kg-cm (13 ft-lb, 17 N-m)**

(e) Install the breather plug and torque it.

**Torque: 200 kg-cm (15 ft-lb, 20 N-m)**



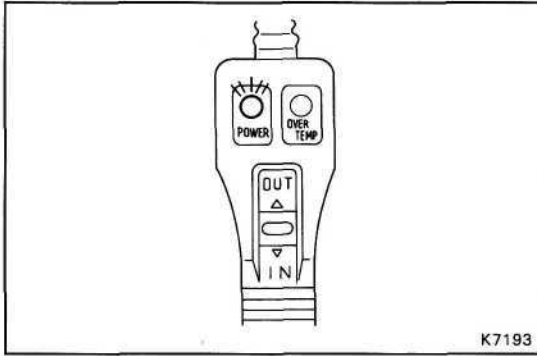

K7193

## ELECTRIC WINCH

### On-Vehicle Inspection

#### INSPECTION OF WINCH REMOTE CONTROL SWITCH

##### 1. CONNECT WINCH CONTROL SWITCH CONNECTOR

##### 2. INSPECT WINCH CONTROL SWITCH

- The power indicator light will light when the winch turns ignition switch ON.
- Operate winch control switch, confirm winch function.

HINT: Be careful not to tighten or strain the winch wire.

- Turn ignition switch OFF.

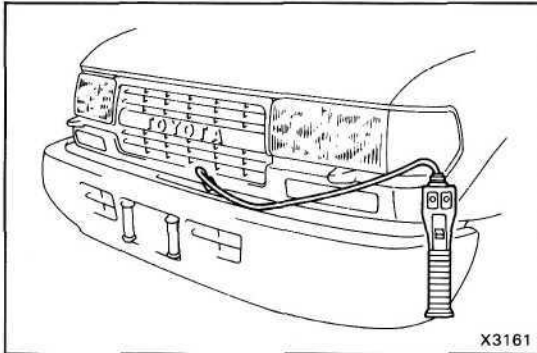

X3161

##### 3. INSPECT OVERHEAT TEMPERATURE INDICATOR

- Remove the front bumper.
- Remove the front base member.
- Remove the four screws and the cover.
- Disconnect the connector of magnet switch No.2.

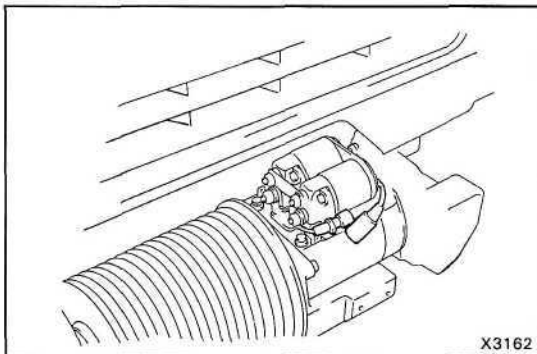

X3162

- When ignition switch ON, the overheat temperature indicator light will light and buzzer sound.
- Turn ignition switch OFF.

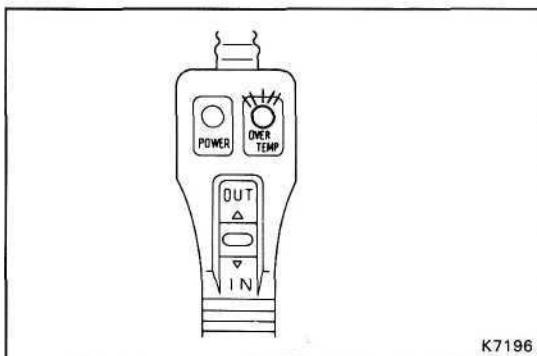

K7196

- Connect the connector.
- Install the four screws and the cover.
- Install the front base member,
- Install the front bumper.

##### 4. DISCONNECT WINCH CONTROL SWITCH CONNECTOR

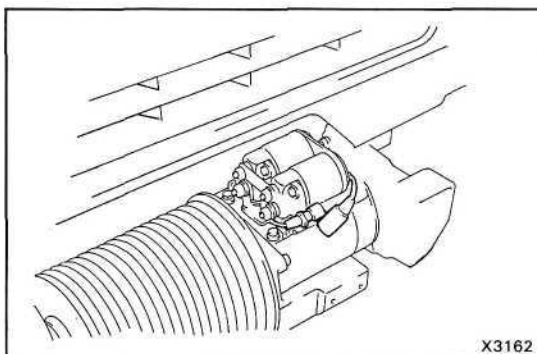

X3162

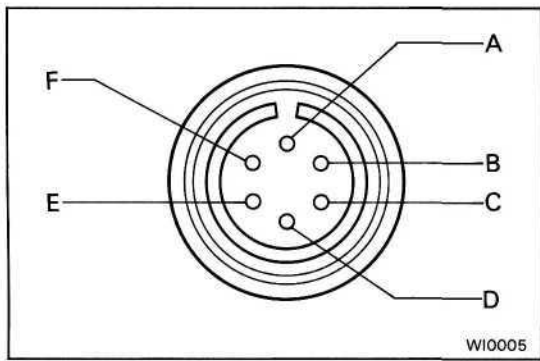

**5. CHECK WINCH REMOTE CONTROL SWITCH CIRCUIT**

Check that there is continuity between terminals.

SW position \ Terminal	A	B	C	D	E	F
NEUTRAL	○	○	○		○	
IN		○	○	○		
OUT		○	○			○

If there is no continuity, replace the remote control switch.

# Removal and Installation of Winch Assembly

Remove and install the parts as shown.

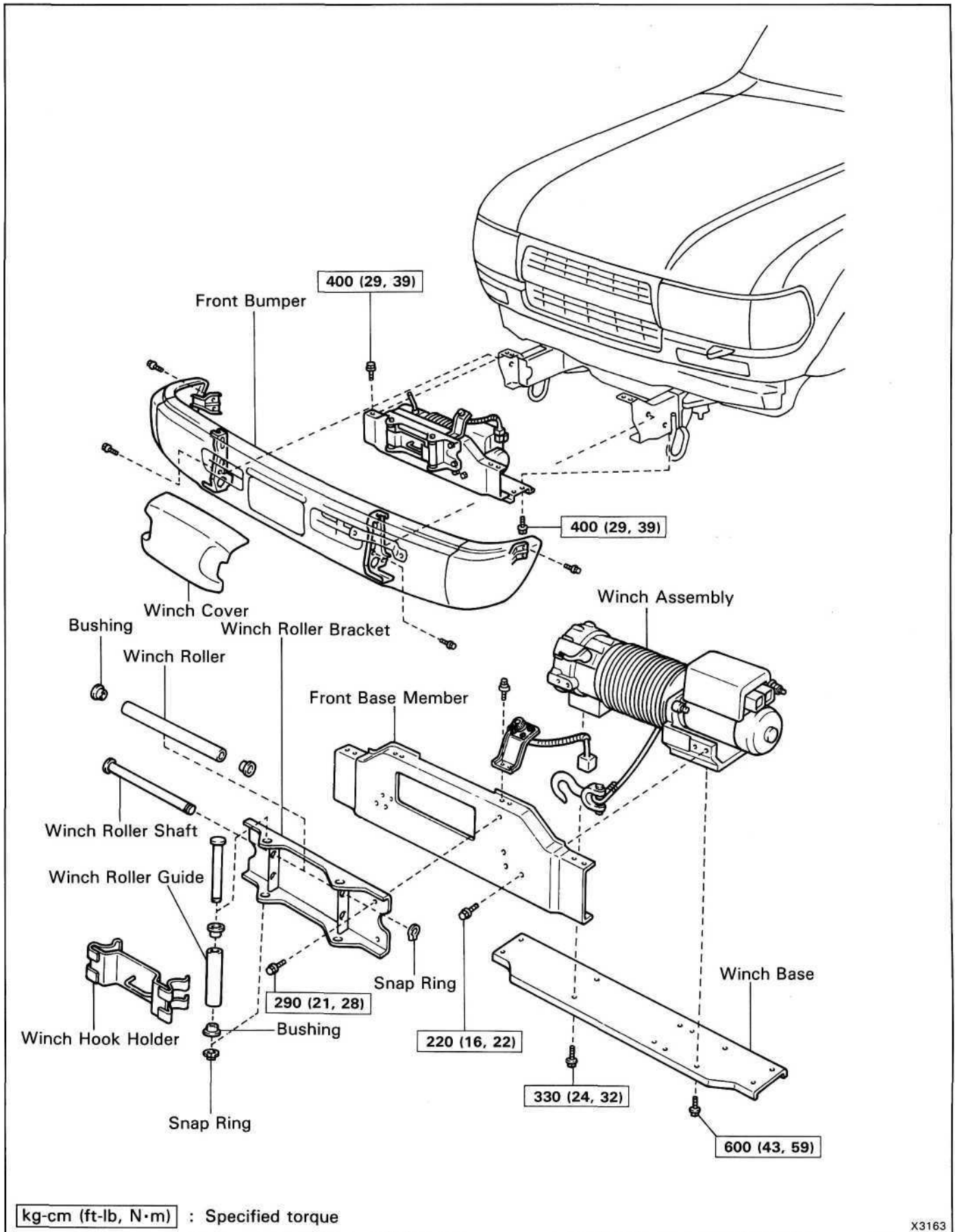

# Winch Assembly

## COMPONENTS

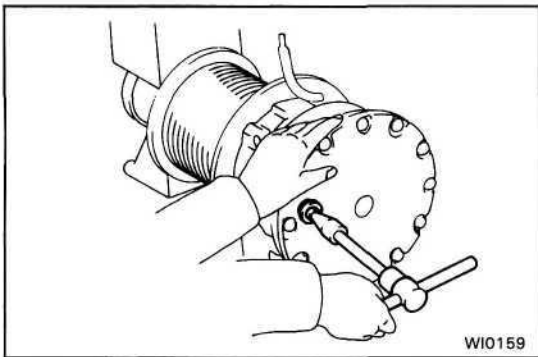
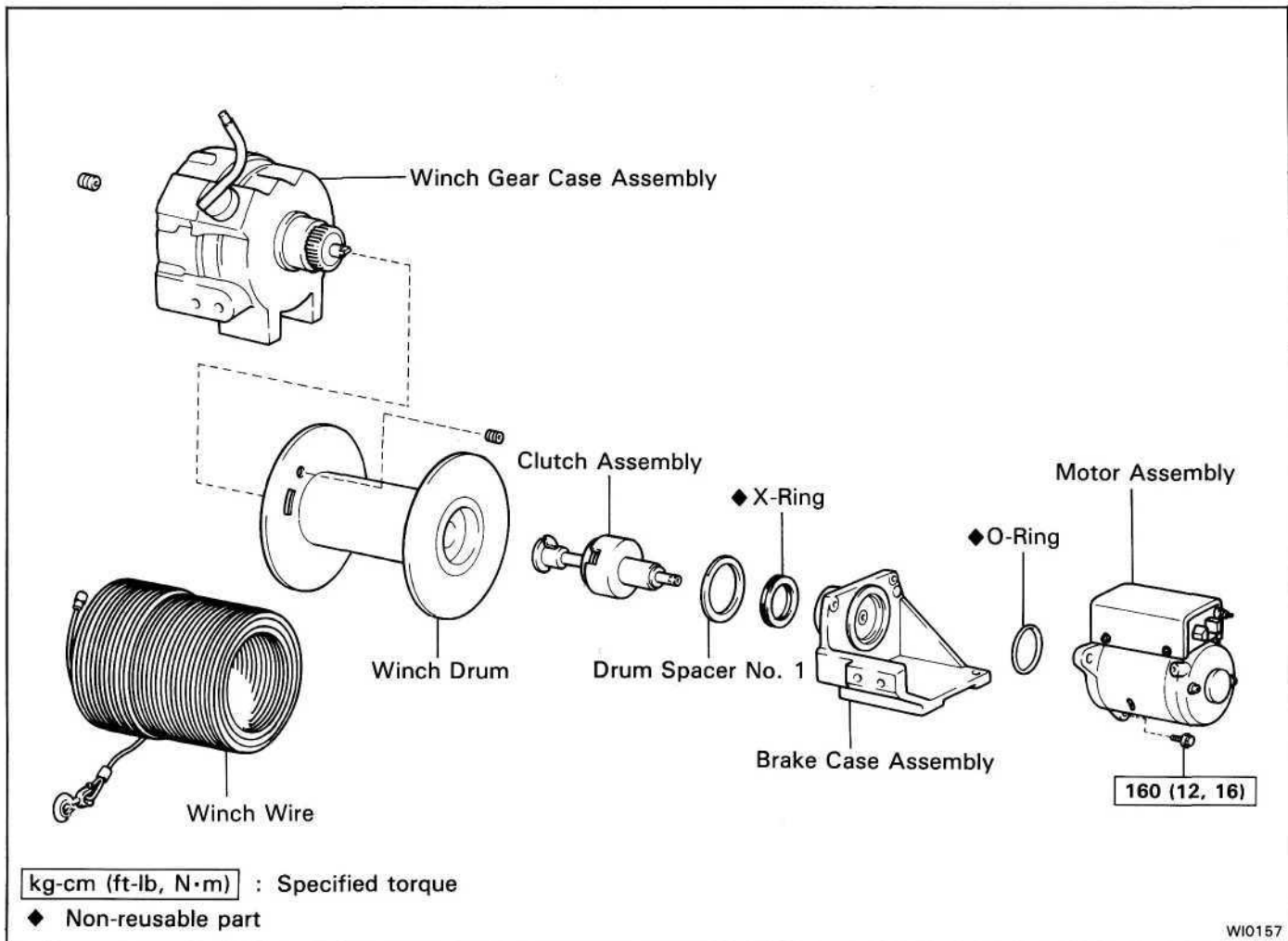

## REMOVAL OF WINCH ASSEMBLY

### 1. DRAIN WINCH FLUID

- (a) Using SST, remove the drain plug.  
SST 09313-30021
- (b) Drain the winch fluid.

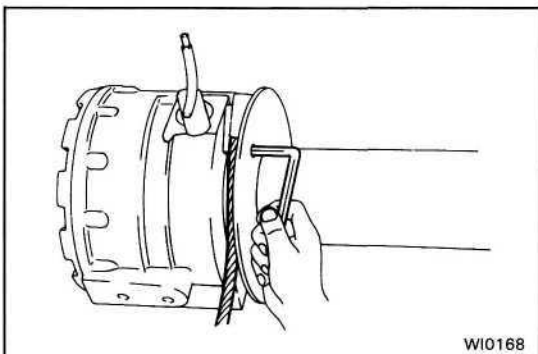

### 2. REMOVE WINCH WIRE

- (a) Shift the shift lever to the free position.
- (b) Pull out the winch wire from the drum.
- (c) Using a hexagon wrench, remove the bolt.
- (d) Remove the winch wire.

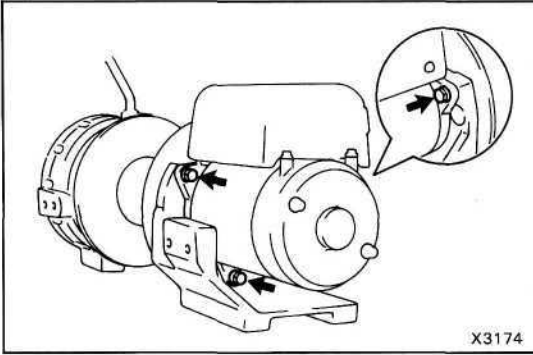
**3. REMOVE WINCH MOTOR ASSEMBLY**

Remove the three bolts, the winch motor assembly and the O-ring.

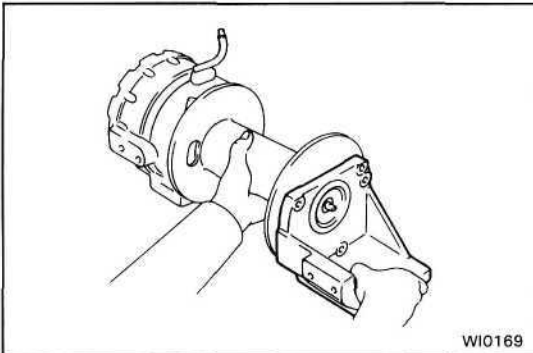
**4. REMOVE WINCH BRAKE CASE**

Remove winch brake case, the X-ring and drum spacer No.1.

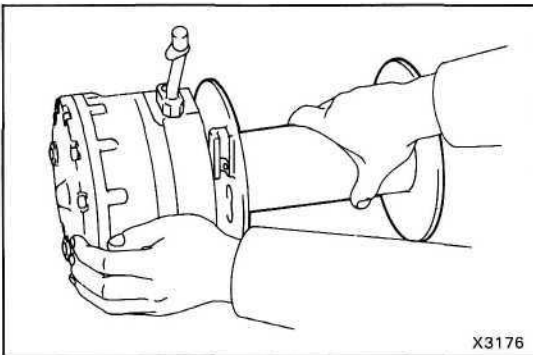
**5. REMOVE WINCH DRUM**

- (a) Remove the clutch assembly.
- (b) Remove the winch drum from the gear case assembly.

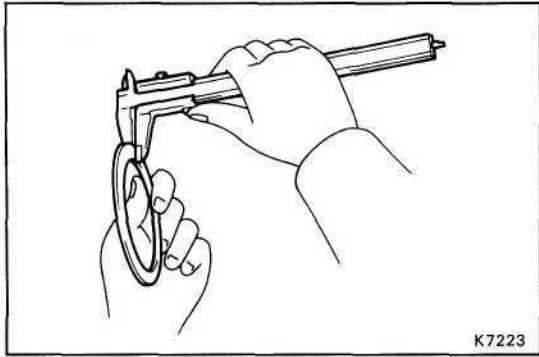

## INSPECTION OF WINCH ASSEMBLY

### 1. INSPECT DRUM SPACER NO. 1

Using calipers, measure the thickness of drum spacer No. 1.

**Standard bore : 1.4 mm (0.0551 in.)**

**Minimum bore : 1.0 mm (0.0394 in.)**

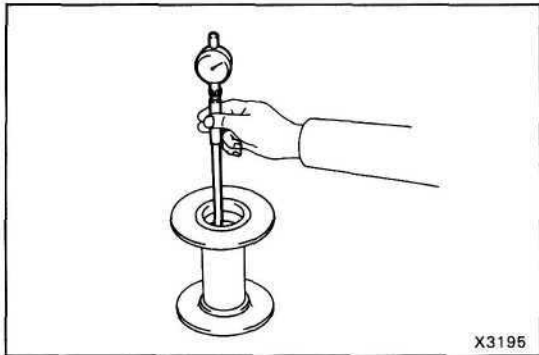

### 2. INSPECT WINCH DRUM

Using a cylinder gauge, measure the each side bushing bore.

**Standard bore : 64.20 mm (2.5276 in.)**

**Maximum bore : 64.36 mm (2.5339 in.)**

**INSTALLATION OF WINCH ASSEMBLY**

(See page WI-28)

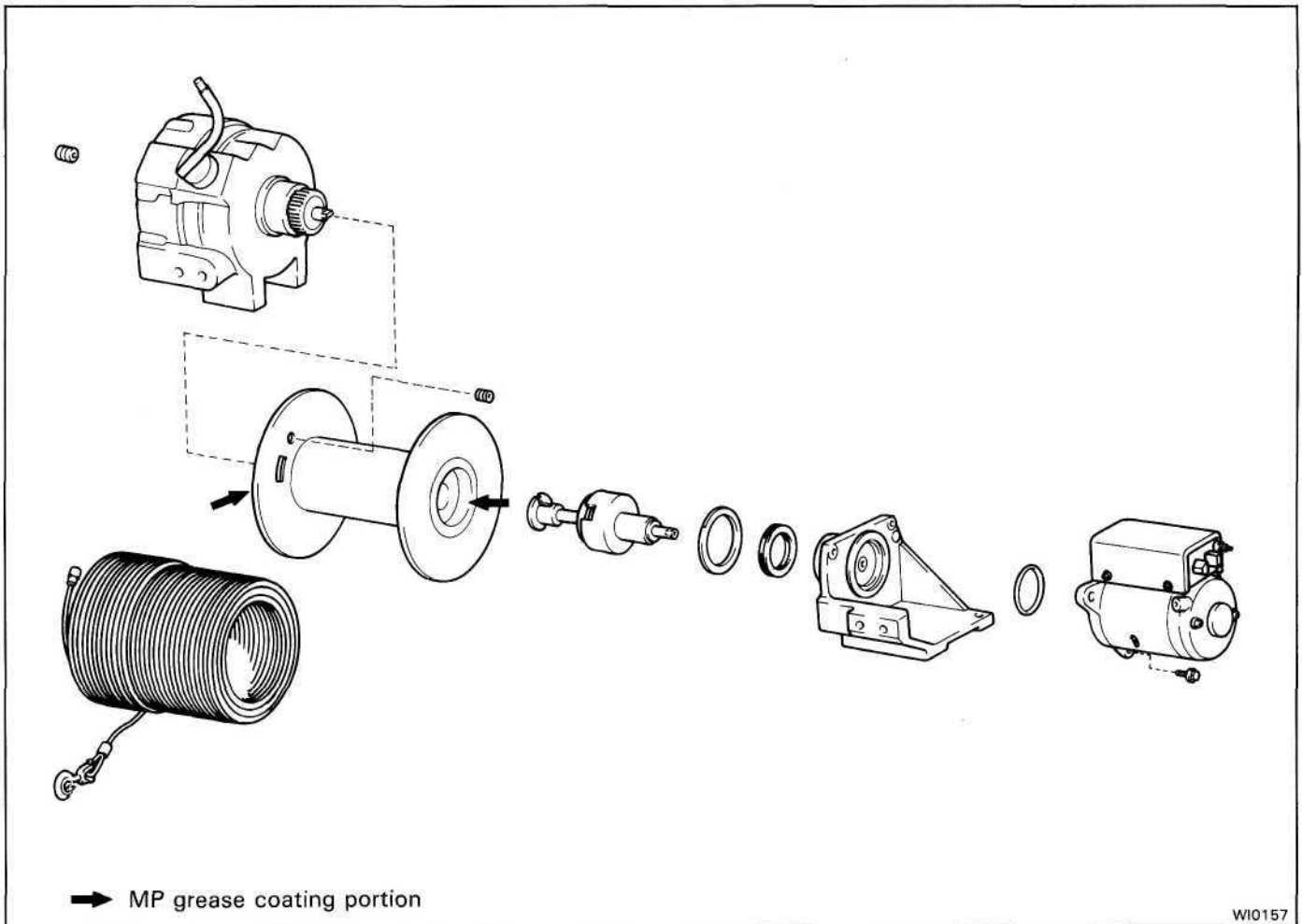
**1. COAT MP GREASE ON FOLLOWING PARTS:****2. INSTALL WINCH DRUM**

- Install the winch drum to the gear case.
- Install the clutch assembly.

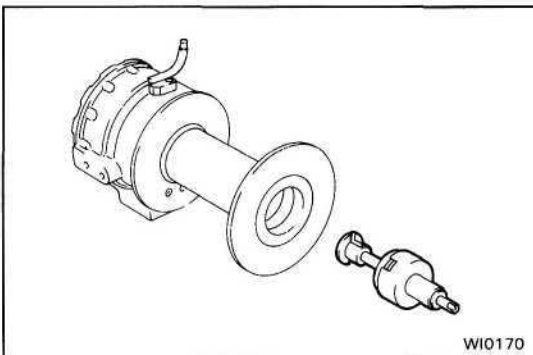
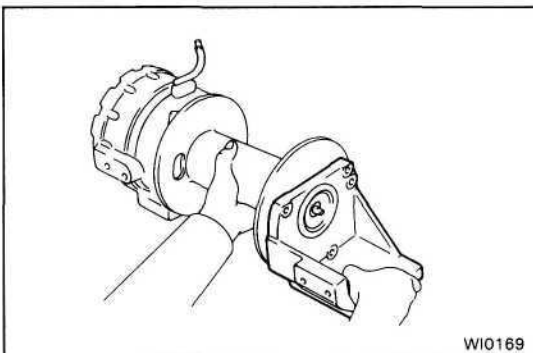
**3. INSTALL WINCH BRAKE CASE**

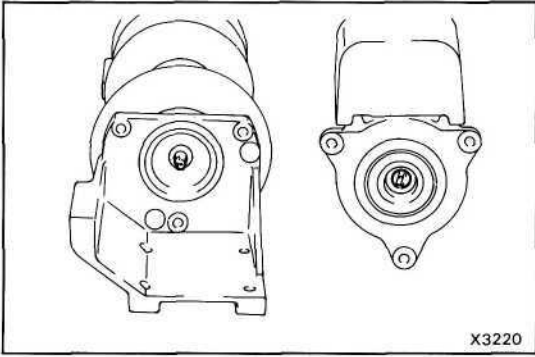

#### 4. INSTALL WINCH MOTOR ASSEMBLY

- (a) Align the groove and the tip of the input shaft.
- (b) Torque the three bolts.

**Torque: 160 kg-cm (12 ft-lb, 16 N-m)**

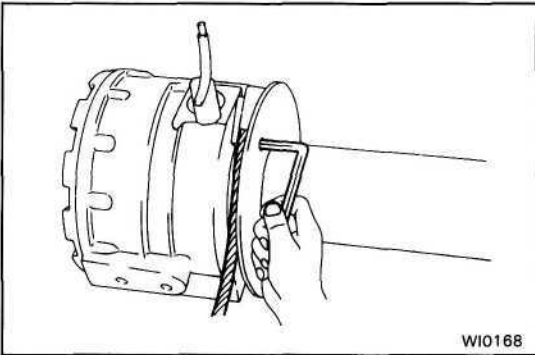

#### 5. INSTALL WINCH WIRE

- (a) Install the winch wire to the winch drum.
- (b) Using a hexagon wrench, install the bolt.
- (c) Wind the winch wire around the winch drum.

**Torque: 10 kg-cm (9 in.-lb, 1.0 N-m)**

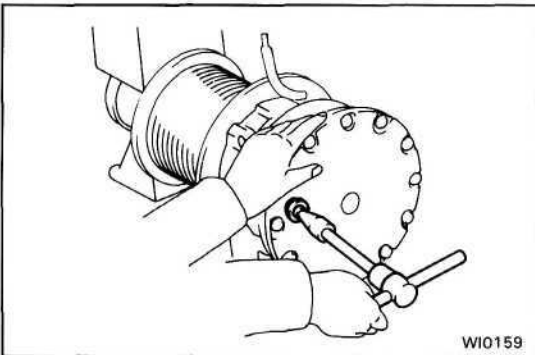

#### 6. FILL WINCH WITH AUTOMATIC TRANSMISSION FLUID

Fill the winch with automatic transmission fluid and torque the drain plug.

**Torque: 175 kg-cm (13 ft-lb, 17 N-m)**

**Oil grade: ATF Type F**

**Capacity: 0.9 liters (0.95 US qts, 0.79 Imp.qts)**



# Winch Components

## COMPONENTS

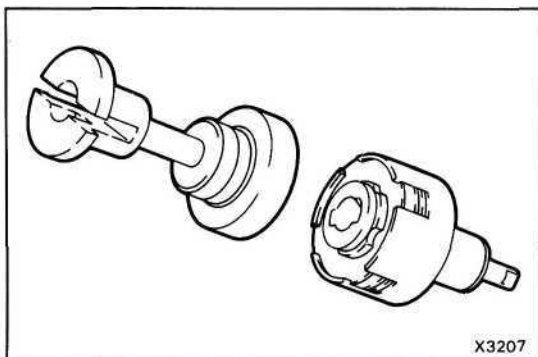
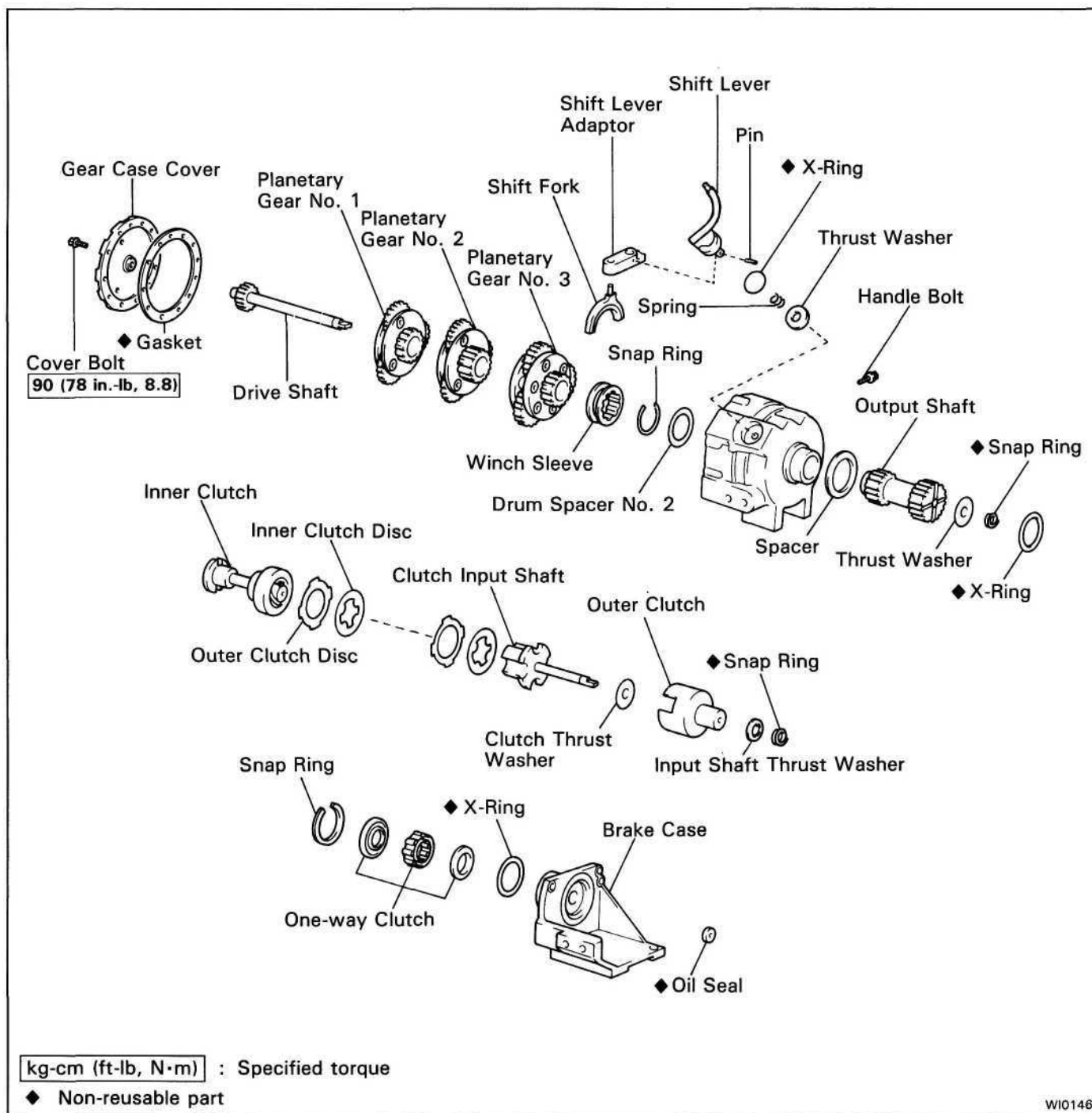

### DISASSEMBLY OF WINCH COMPONENTS

1. REMOVE INNER CLUTCH, CLUTCH DISCS FROM OUTER CLUTCH

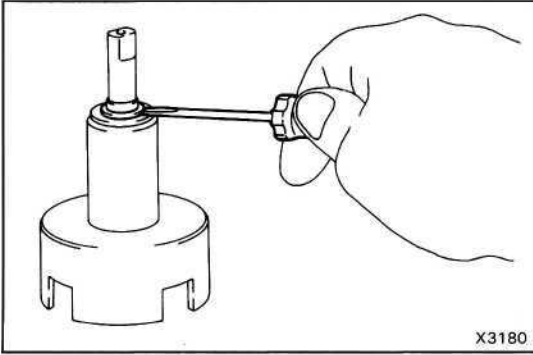

X3180

## 2. REMOVE OUTER CLUTCH

- (a) Using a screwdriver, remove the snap ring.
- (b) Remove the thrust washer.
- (c) Remove the clutch input shaft and thrust washer.

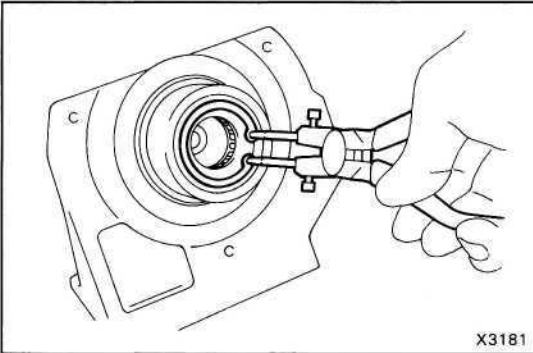

X3181

## 3. REMOVE ONE-WAY CLUTCH FROM BRAKE CASE

- (a) Using snap ring pliers, remove the snap ring.
- (b) Remove the one-way clutch.
- (c) Remove the X-ring.

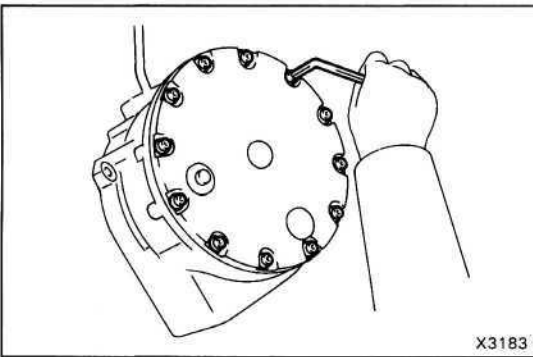

X3183

## 4. REMOVE GEAR CASE COVER

Using a hexagon wrench, remove the gear case cover and gasket.

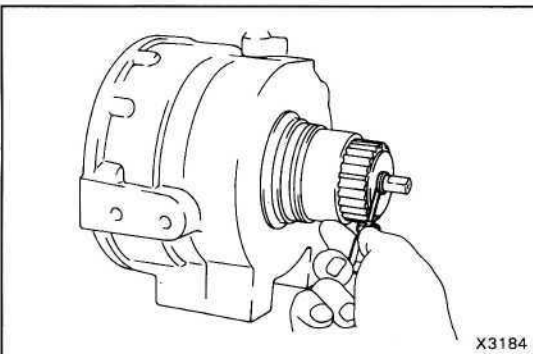

X3184

## 5. REMOVE PLANETARY GEAR NO.1, NO.2, NO.3 AND DRIVE SHAFT

- (a) Using a screwdriver, remove the snap ring.
- (b) Remove the thrust washer.
- (c) Remove the X-ring.

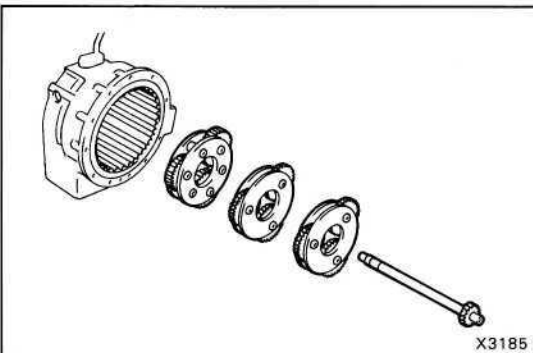

X3185

- (d) Pull out the drive shaft, and remove the planetary gear No.1, No.2 and No.3.

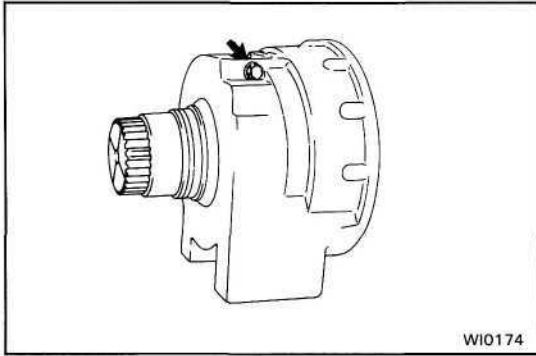

## 6. REMOVE SHIFT LEVER

(a) Remove the handle bolt.

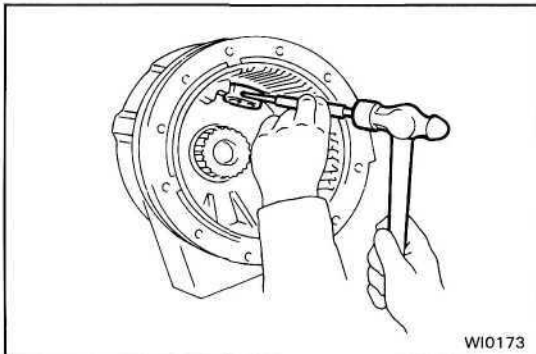

(b) Using a pin punch and a hammer, tap out the pin.

(c) Turn the shift lever adaptor a half turn, then pull out the pin with pliers.

(d) Remove the shift lever adaptor.

(e) Remove the shift lever.

(f) Remove the thrust washer, spring and X-ring.

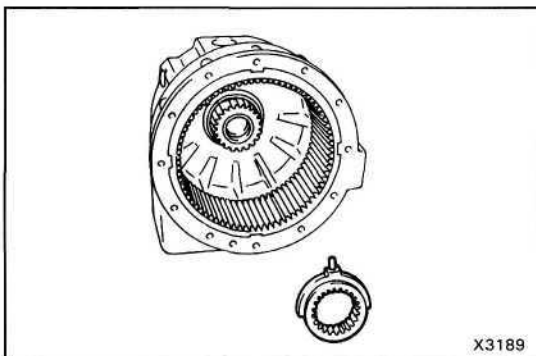

## 7. REMOVE WINCH SLEEVE WITH SHIFT FORK

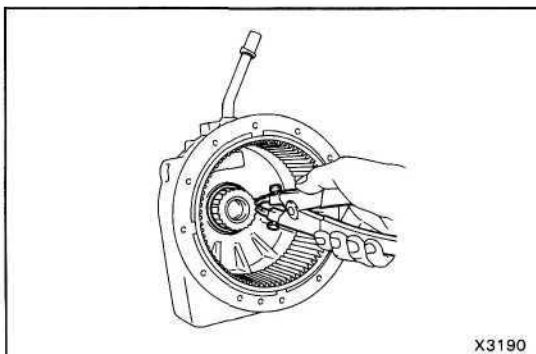

## 8. REMOVE OUTPUT SHAFT

(a) Using snap ring pliers, remove the snap ring and drum spacer No.2.

(b) Remove the output shaft and spacer.

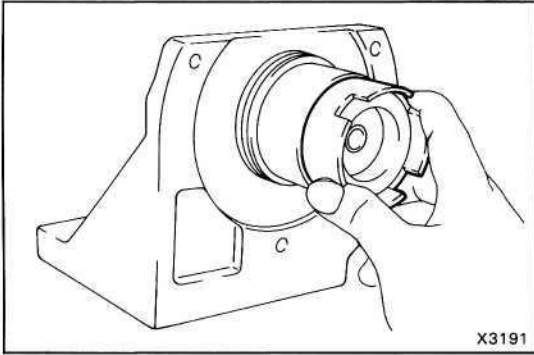

X3191

## INSPECTION AND REPLACEMENT OF WINCH COMPONENTS

### 1. INSPECT ONE-WAY CLUTCH

- (a) Install one-way clutch.  
(See page WI-41)
- (b) Install the outer clutch and turn it. Then the outer clutch turns freely counterclockwise and locks clockwise.
- (c) If necessary, replace the one-way clutch.

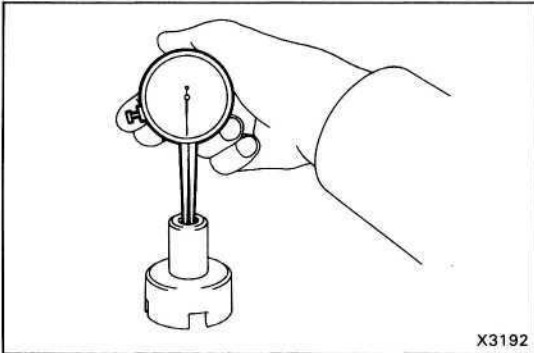

X3192

### 2. INSPECT OUTER CLUTCH

- (a) Using a caliper gauge, measure the bushing bore.

**Standard bore : 12.00 mm (0.4724 in.)**

**Maximum bore : 12.03 mm (0.4736 in.)**

- (b) Inspect the outer clutch for wear or damage.  
If necessary, replace the drive shaft.

**Standard outer diameter: 27.77 mm (1.0933 in.)**

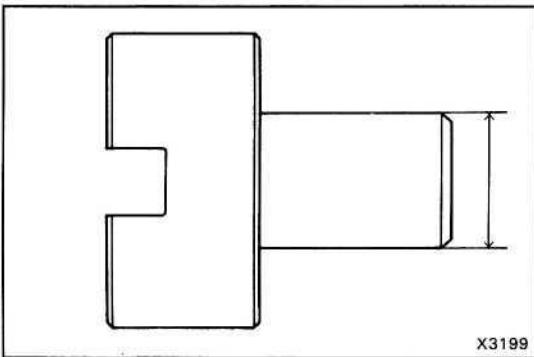

X3199

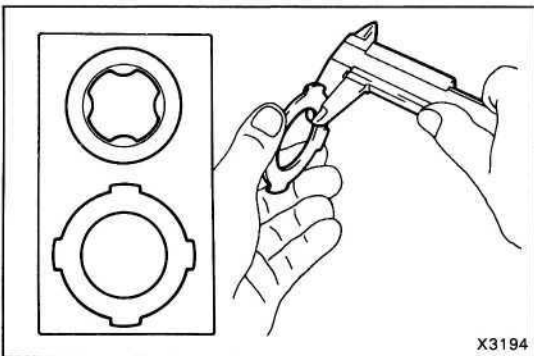

X3194

### 3. INSPECT CLUTCH OUTER DISC AND INNER DISC

Using calipers, measure the thickness of clutch outer disc and inner disc.

#### Outer disc:

**Standard thickness : 1.60 mm (0.0630 in.)**

**Minimum thickness : 1.50 mm (0.0591 in.)**

#### Inner disc:

**Standard thickness : 2.30 mm (0.0906 in.)**

**Minimum thickness : 2.15 mm (0.0846 in.)**

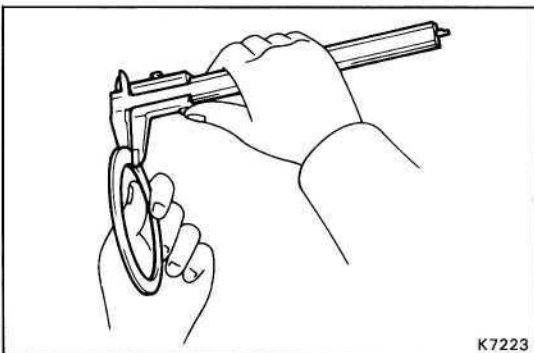

K7223

### 4. INSPECT DRUM SPACER NO.2

Using calipers, measure the thickness of drum spacer No. 2.

**Standard thickness : 1.4 mm (0.0551 in.)**

**Minimum thickness : 1.0 mm (0.0394 in.)**

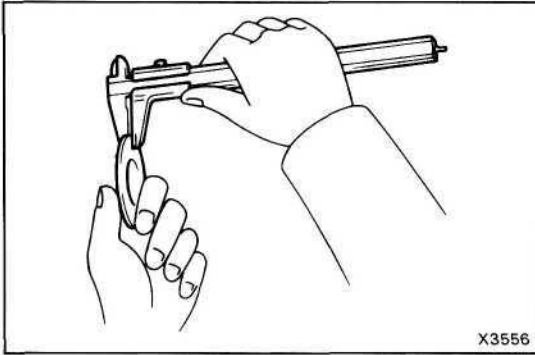

#### 5. INSPECT INPUT SHAFT THRUST WASHER, CLUTCH THRUST WASHER

Using calipers, measure the thickness of thrust washers.

##### INPUT SHAFT THRUST WASHER

**Standard thickness : 2.00 mm (0.0787 in.)**

**Minimum thickness : 1.80 mm (0.0709 in.)**

##### CLUTCH THRUST WASHER

**Standard thickness : 1.25 mm (0.0492 in.)**

**Minimum thickness : 1.00 mm (0.0394 in.)**

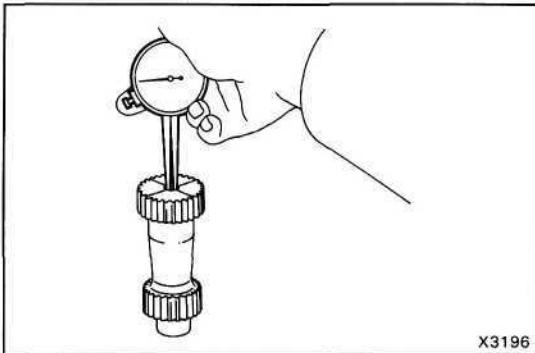

#### 6. INSPECT OUTPUT SHAFT

(a) Using a caliper gauge, measure the bushing bore.

**Standard bore : 12.00 mm (0.4724 in.)**

**Maximum bore : 12.03 mm (0.4736 in.)**

(b) Using a caliper, measure the outer diameter of the bushing.

**Standard diameter : 28.00 mm (1.1024 in.)**

**Minimum diameter : 27.90 mm (1.0984 in.)**

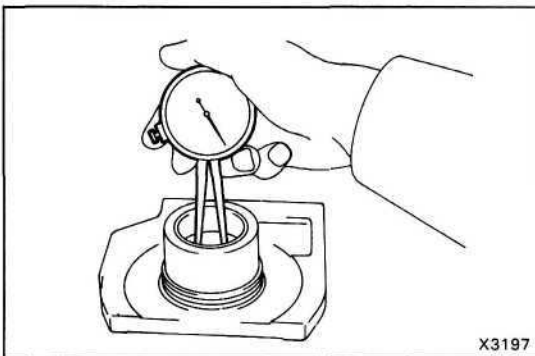

#### 7. INSPECT BRAKE CASE

Using calipers, measure the bushing bore.

**Standard bore : 27.76 mm (1.0929 in.)**

**Maximum bore : 27.82 mm (1.0953 in.)**

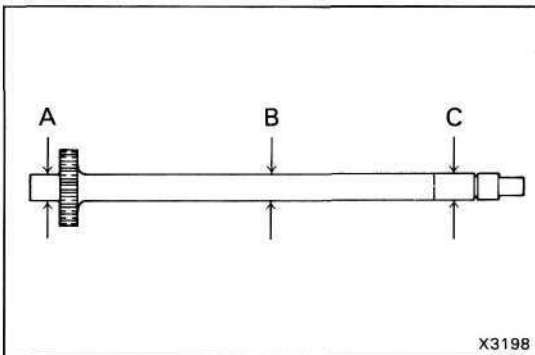

#### 8. INSPECT DRIVE SHAFT

(a) Inspect the drive shaft for wear or damage the drive shaft.

(b) Using a micrometer, measure the outer diameter of the drive shaft.

**Minimum outer diameter:**

**Part A : 11.86 mm (0.4669 in.)**

**B: 11.70 mm (0.4606 in.)**

**C : 11.95 mm (0.4705 in.)**

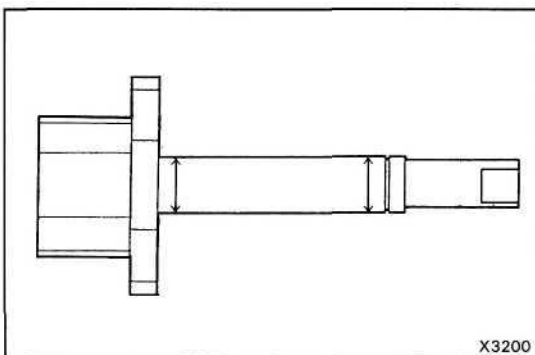

#### 9. INSPECT CLUTCH INPUT SHAFT

Inspect clutch input shaft for wear or damage.

If damage, replace the clutch input shaft.

**Standard outer diameter: 11.95 mm (0.4705 in.)**

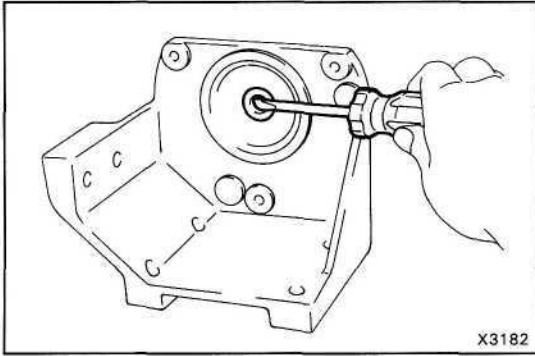

## 10. REPLACE WINCH BRAKE CASE OIL SEAL

(a) Using a screwdriver, pry out the oil seal.

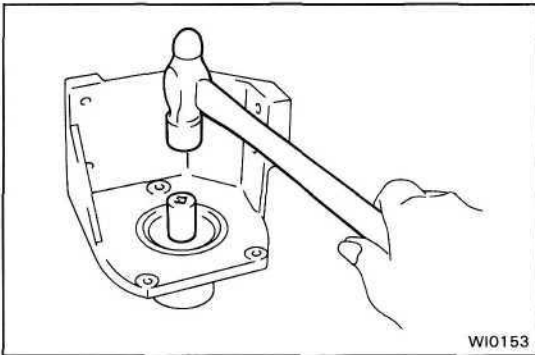

(b) Using a socket wrench, install the oil seal.

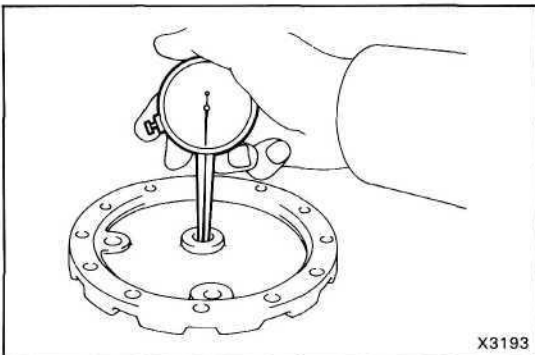

## 11. INSPECT WINCH GEAR CASE COVER

Using a caliper gauge, measure the bushing bore.

**Standard bore: 12.00 mm (0.4724 in.)**

**Maximum bore: 12.15 mm (0.4783 in.)**

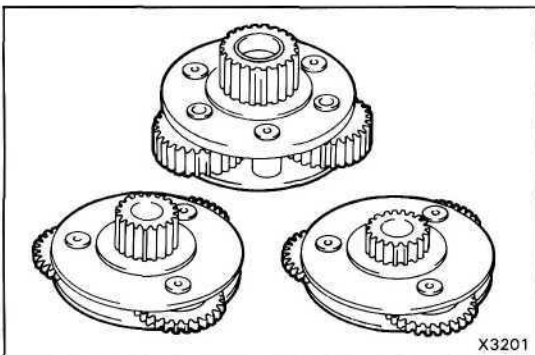

## 12. INSPECT PLANETARY GEAR NO.1, NO.2 AND NO.3

(a) Check that the bearing rotates smoothly.

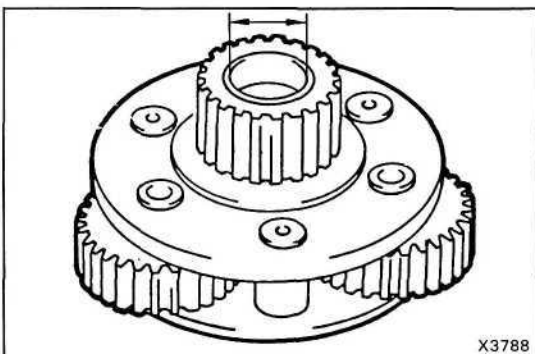

(b) Using a caliper gauge, measure the bushing bore of the planetary gear No.3.

**Standard bore: 28.00 mm (1.1024 in.)**

**Maximum bore: 28.05 mm (1.1043 in.)**

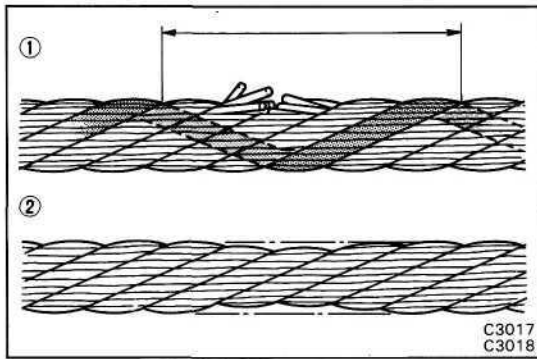

### 13. INSPECT WINCH WIRE

Inspect the winch wire for the following items.

If damage, replace the winch wire.

- Wire with 12 severed strands per wind.
- Wire diameter of less than 7.5 mm (0.295 in.)

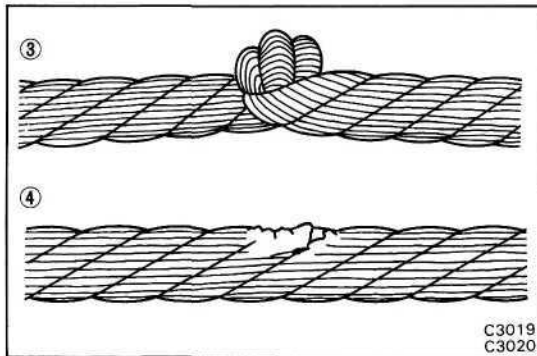

- Kinks
- Corrosion
- Fraying

**ASSEMBLY OF WINCH COMPONENTS**

(See page WI-33)

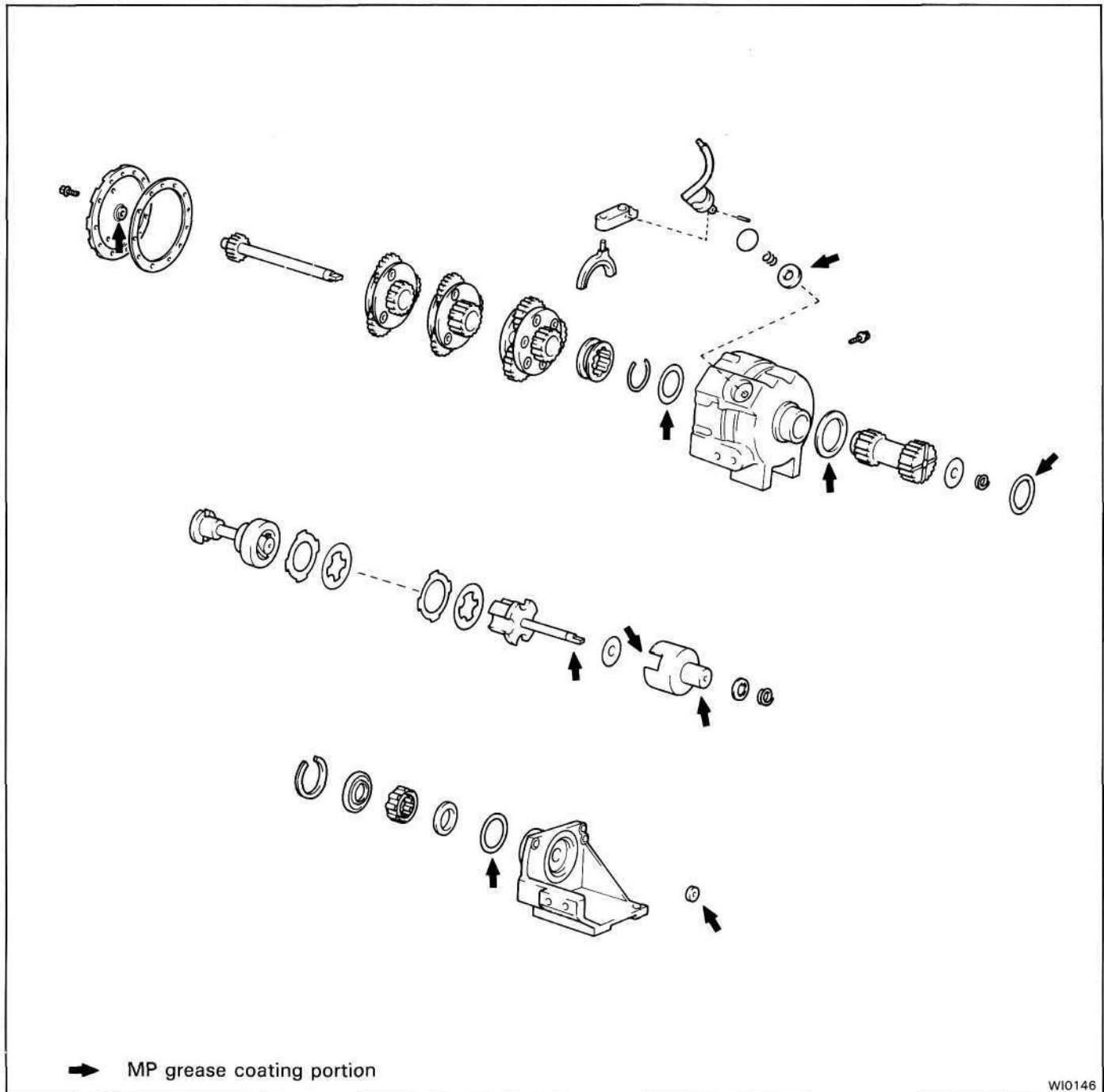
**1. COAT MP GREASE ON FOLLOWING PARTS:**

WI0146

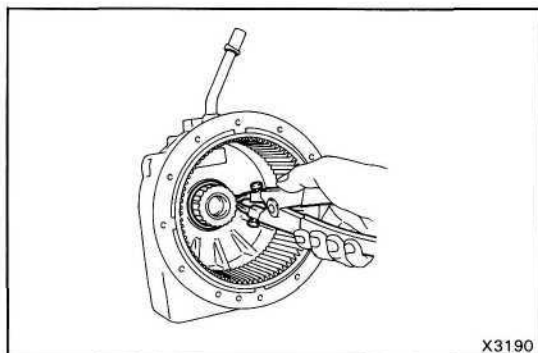

X3190

**2. INSTALL OUTPUT SHAFT**

- (a) Install output shaft to the gear case.
- (b) Using snap ring pliers, install the snap ring.



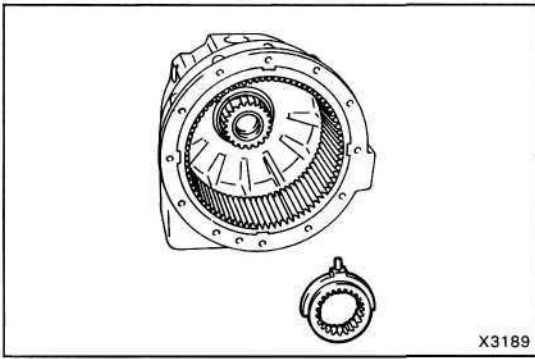

**3. INSTALL WINCH SLEEVE WITH SHIFT FORK**

**4. INSTALL SHIFT LEVER**

- (a) Install a new O-ring, the spring and the thrust washer.
- (b) Install the shift lever adapter.
- (c) Install the shift lever.

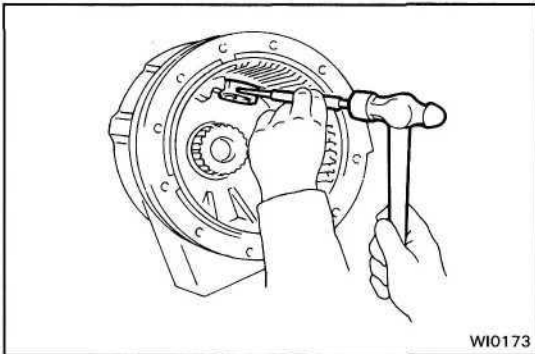

- (d) Using a pin punch and a hammer, drive in the pin.

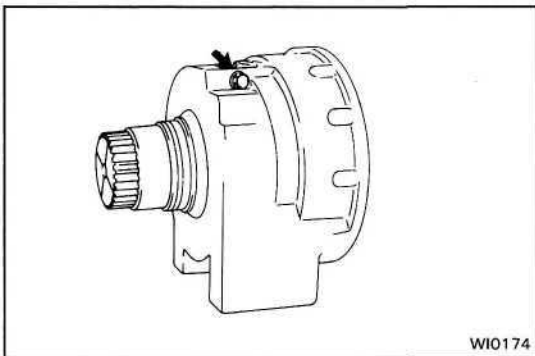

- (e) Install the handle bolt.

**Torque: 45 kg-cm (39 in.-lb, 4.4 N-m)**

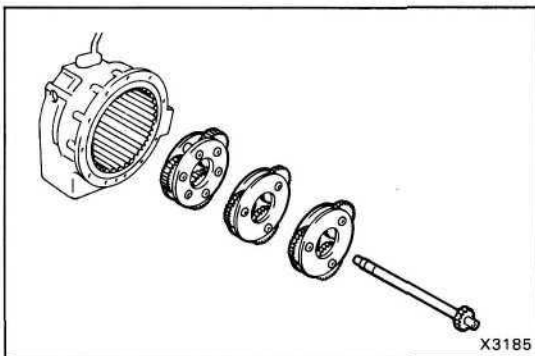

**5. INSTALL PLANETARY GEAR NO.3, NO.2, NO.1 AND DRIVE SHAFT**

- (a) Coat the each gear with ATF.

**Fluid type: ATF DEXRON® H**

- (b) Install the planetary gear No.3, No.2, No.1 and the drive shaft.

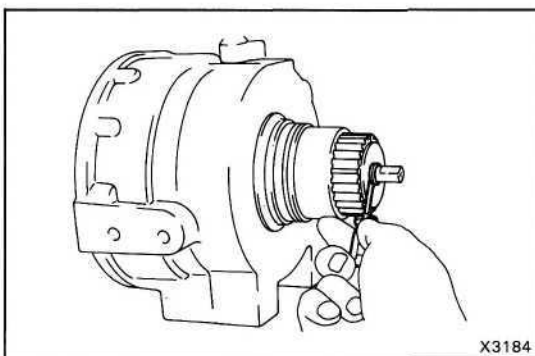

- (c) Install a new X-ring.
- (d) Install the thrust washer.
- (e) Install the snap ring.

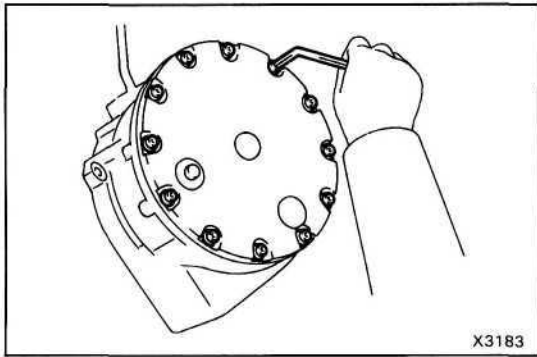

#### 6. INSTALL GEAR CASE COVER

Using a hexagon wrench, install a new gasket and the gear case cover.

**Torque: 90 kg-cm (78 in.-lb, 8.8 N-m)**

#### 7. INSTALL ONE-WAY CLUTCH

- (a) Install a new X-ring.
- (b) Install the one-way clutch.
- (c) Coat the one-way clutch with ATF.

**Fluid type: ATF DEXRON® I**

**HINT:** Install in proper direction only.

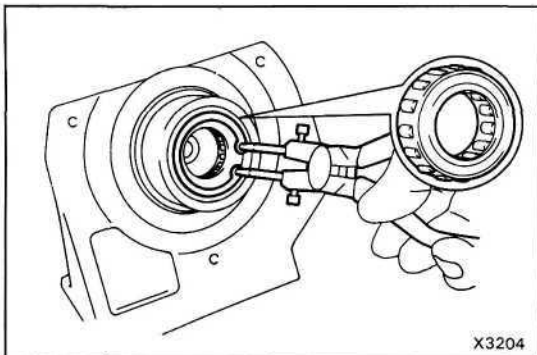

- (d) Using snap ring pliers, install the snap ring.

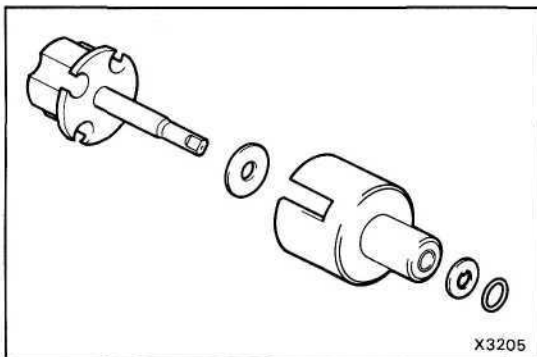

#### 8. INSTALL OUTER CLUTCH

- (a) Install the clutch input shaft and thrust washer to the outer clutch.
- (b) Install the input shaft thrust washer and the snap ring.

- (c) Install the inner disc and the outer disc to the outer clutch.

**HINT:** Before assembly new clutch discs, soak them in automatic transmission fluid for at least two hours.

**Fluid type: ATF DEXRON® H**

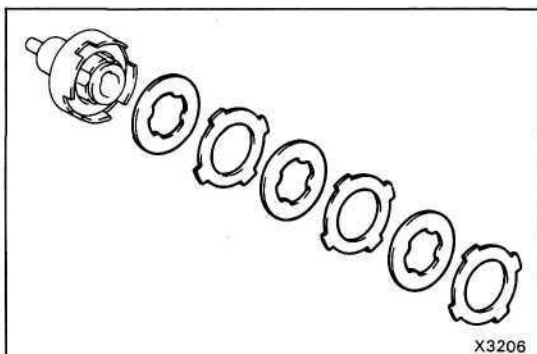

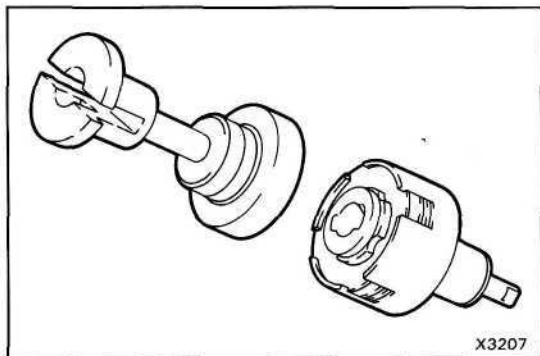

(d) Install the inner clutch.

HINT: Coat the threads of the inner clutch with ATF and install inner clutch.

# Winch Motor

## COMPONENTS

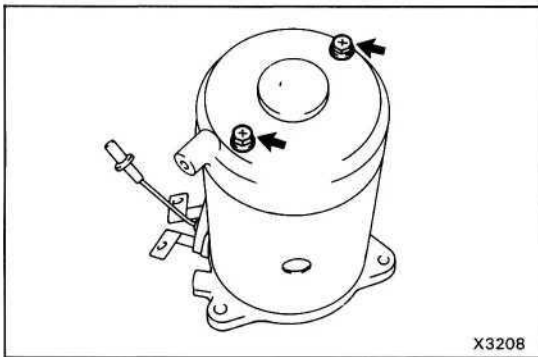
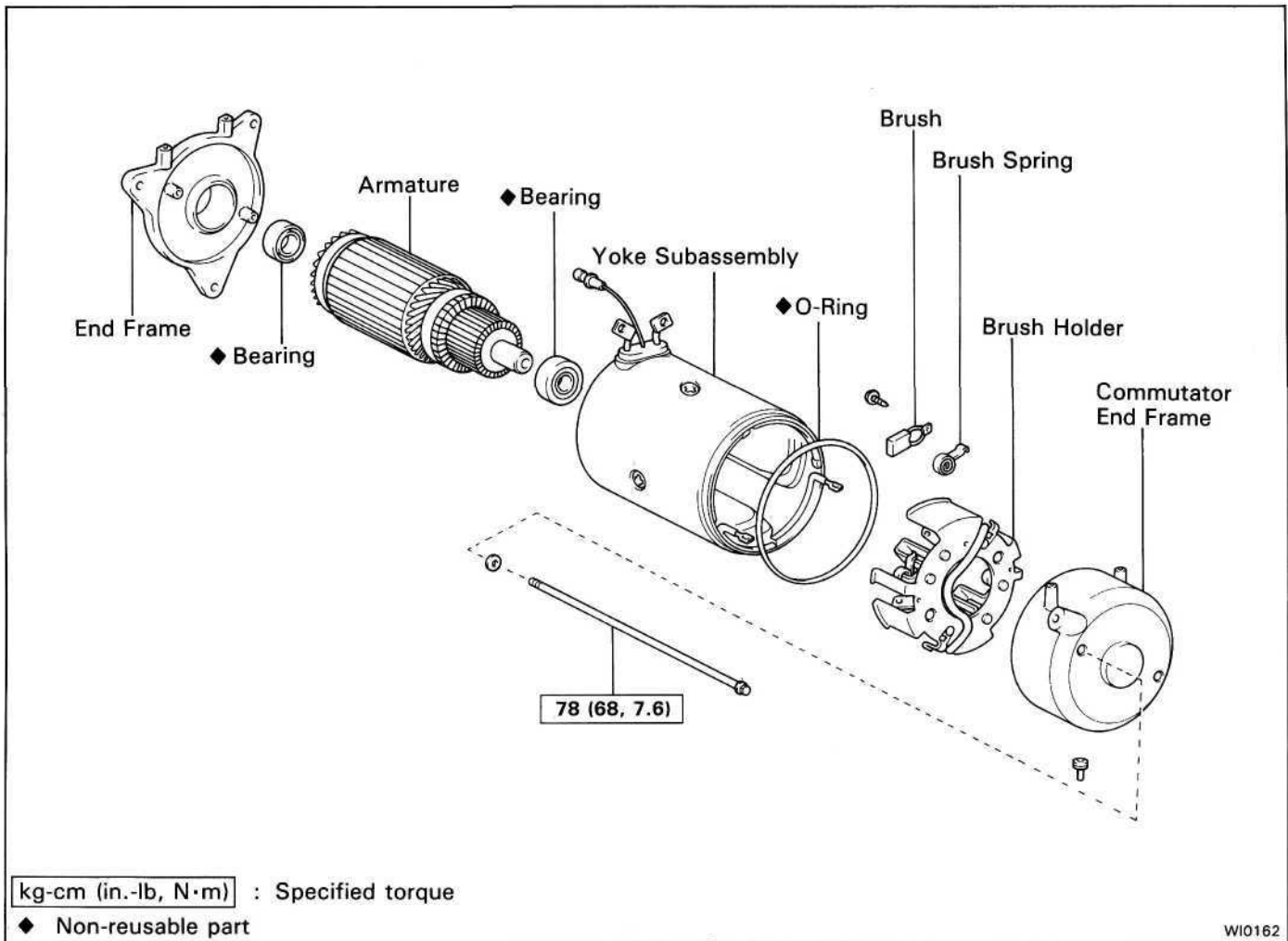

### DISASSEMBLY OF WINCH MOTOR

#### 1. REMOVE COMMUTATOR END FRAME

- (a) Remove the two bolts.
- (b) Remove the commutator end frame and O-ring.

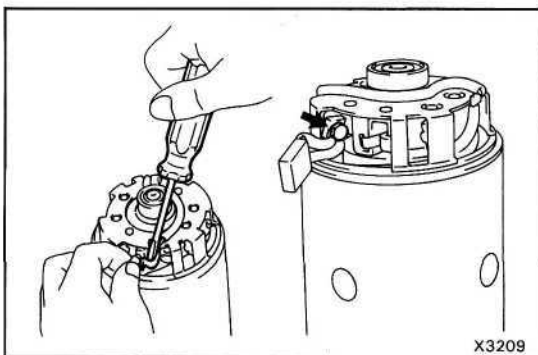

#### 2. REMOVE BRUSHES

- (a) Using a screwdriver, remove the negative brushes from the brush holder.

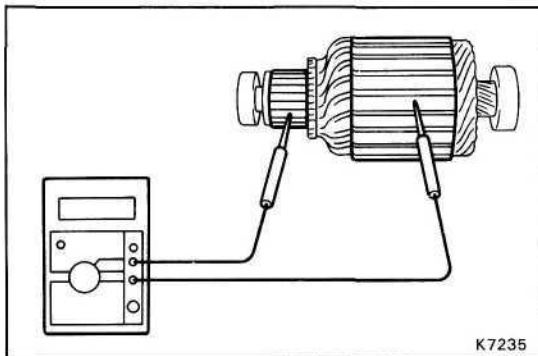

## INSPECTION OF WINCH MOTOR

### 1. INSPECT THAT COMMUTATOR IS NOT GROUNDED

Using an ohmmeter, check that there is no continuity between the commutator and armature core. If there is continuity, replace the armature.

### 2. INSPECT COMMUTATOR FOR DIRTY OR BURNT SURFACE

If the surface is dirty or burnt, clean with sandpaper (No.400) or a lathe.

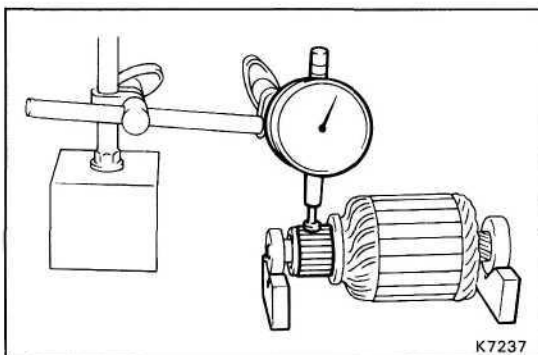

### 3. INSPECT COMMUTATOR CIRCLE RUNOUT

Using a dial indicator, measure the circle runout of the commutator. If the circle runout is greater than the maximum, correct with a lathe.

**Standard runout: 0.05 mm (0.0020 in.) or less**

**Maximum runout: 0.2 mm (0.008 in.)**

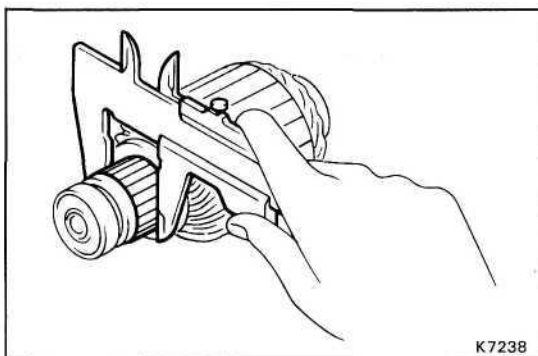

### 4. MEASURE DIAMETER OF COMMUTATOR

Using calipers, measure the diameter of the commutator. If the diameter of the commutator is less than minimum, replace the armature.

**Standard diameter: 43 mm (1.69 in.)**

**Minimum diameter: 41 mm (1.61 in.)**

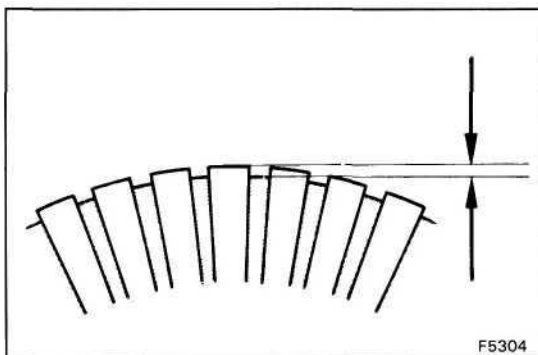

### 5. INSPECT UNDERCUT DEPTH

Check that the undercut depth is clean and free of foreign particles. Then smooth off the edge. If the undercut depth is less than the minimum, correct with a hacksaw blade.

**Standard under cut depth:**

**0.5 - 0.8 mm (0.020 - 0.031 in.)**

**Minimum undercut depth:**

**0.2 mm (0.008 in.)**

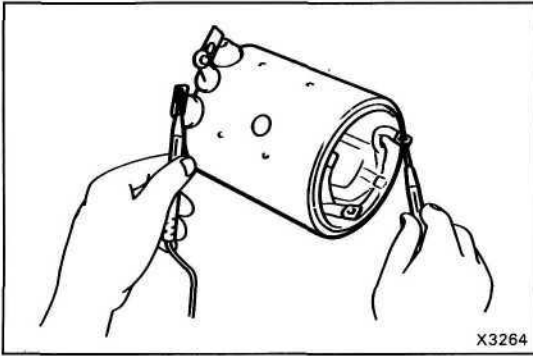

#### 6. INSPECT FIELD COIL FOR OPEN CIRCUIT

Using an ohmmeter, check for continuity between the lead wire and field coil brush lead. If there is no continuity, replace the field coil.

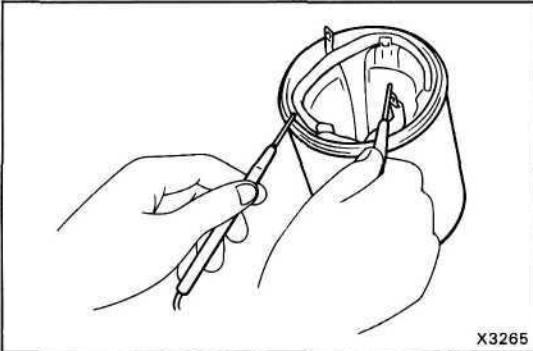

#### 7. INSPECT THAT FIELD COIL IS NOT GROUNDED

Using an ohmmeter, check for continuity between the field coil brush lead and field frame. If there is continuity, repair or replace the yoke subassembly.

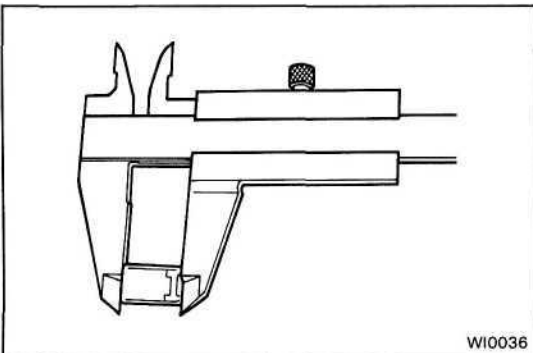

#### 8. MEASURE BRUSH LENGTH

Using calipers, measure length of the brush.

**Standard length: 22 mm (0.87 in.)**

**Minimum length: 15 mm (0.59 in.)**

If the brush length is less than the minimum, replace the brush.

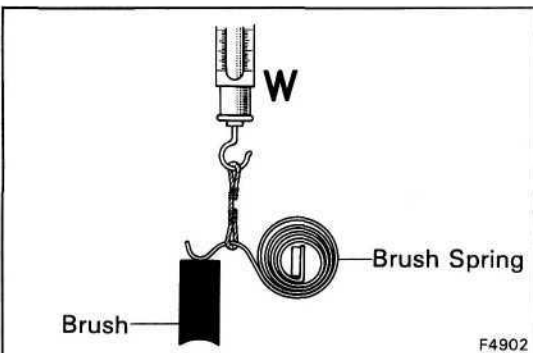

#### 9. MEASURE BRUSH SPRING LOAD

Using a pull scale, measure the installed load of the brush spring.

**Standard installed load: 1.8 kg (4.0 lb, 18 N)**

**HINT:** Take the pull scale reading at the very instant the brush spring separates from the brush.

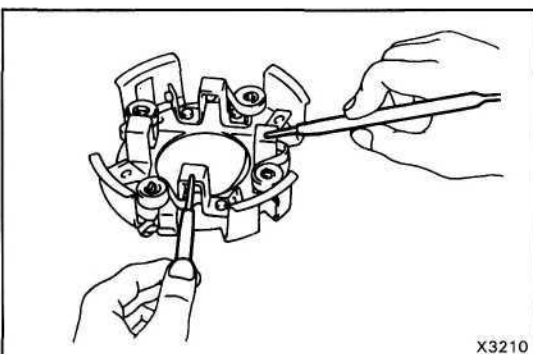

#### 10. INSPECT BRUSH HOLDER

Using an ohmmeter, check for continuity between the positive and negative brush holders. If there is continuity, replace the brush holder assembly.

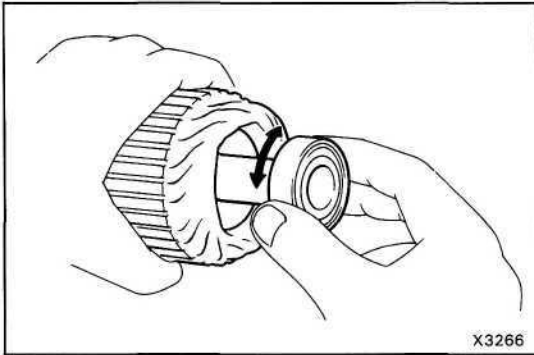
**11. INSPECT BEARING**

Turn each bearing by hand while applying inward force. If the bearing sticks or resists, replace it.

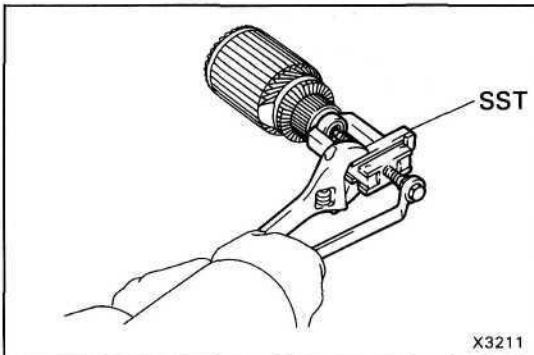
**12. IF NECESSARY, REPLACE BEARINGS**

(a) Using SST, remove the bearing.  
SST 09286-46011

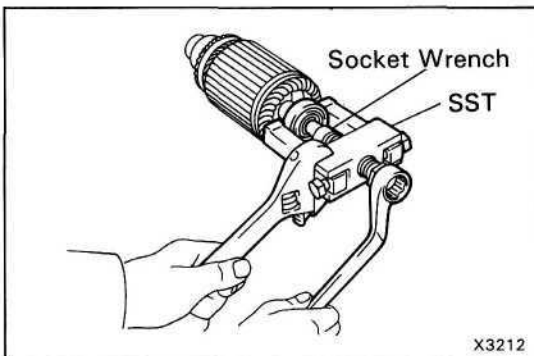

(b) Using SST, remove the bearing.  
SST 09628-62011

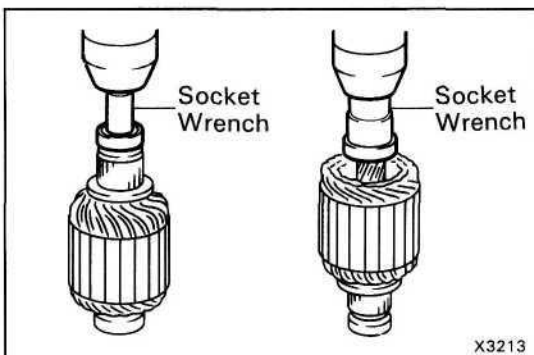

(c) Using a socket wrench and a press, press in a new bearing.

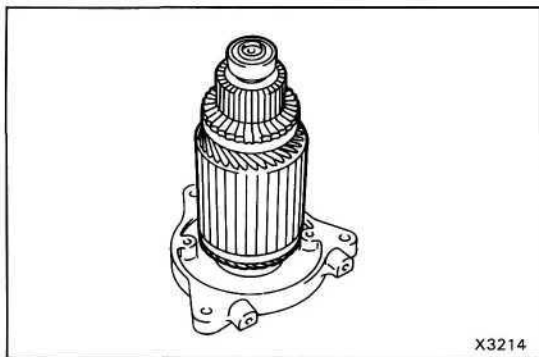

X3214

## ASSEMBLY OF WINCH MOTOR

(See page WI-44)

### 1. INSTALL ARMATURE AND YOKE TO END FRAME

- (a) Apply high temperature grease to the inside of the end frame bushing.
- (b) Install the armature to the end frame.

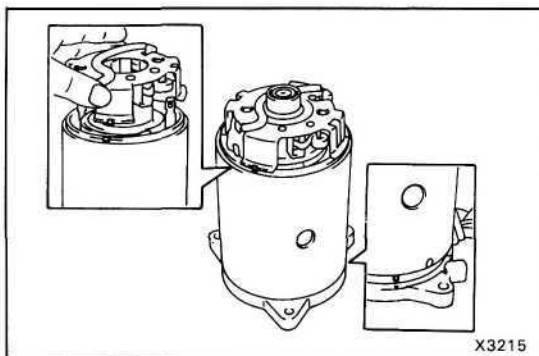

X3215

### 2. INSTALL YOKE SUBASSEMBLY AND BRUSH HOLDER

Align the alignment mark, install the yoke subassembly to the end frame and the brush holder to the yoke subassembly.

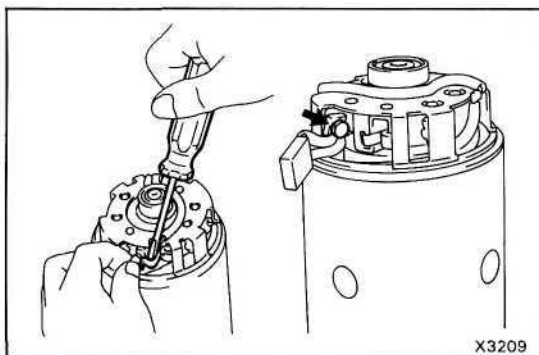

X3209

### 3. INSTALL BRUSH

Torque: 35 kg-cm (30 in.-lb, 3.4 N-m)

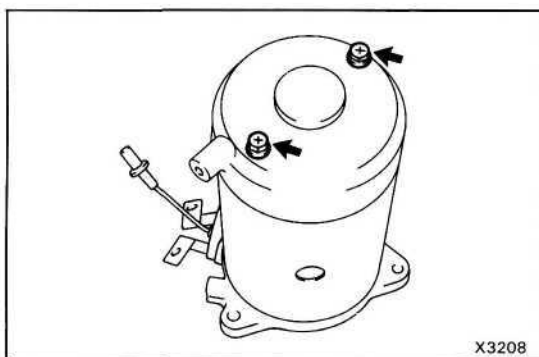

X3208

### 4. INSTALL COMMUTATOR END FRAME

- (a) Apply MP grease to a new O-ring.
- (b) Install a new O-ring on the yoke.
- (c) Torque the two bolts.

Torque: 78 kg-cm (68 in.-lb, 7.7 N-m)



# Magnet Switch No.1

## REMOVAL AND INSTALLATION OF MAGNET SWITCH NO.1

Remove and install the parts as shown.

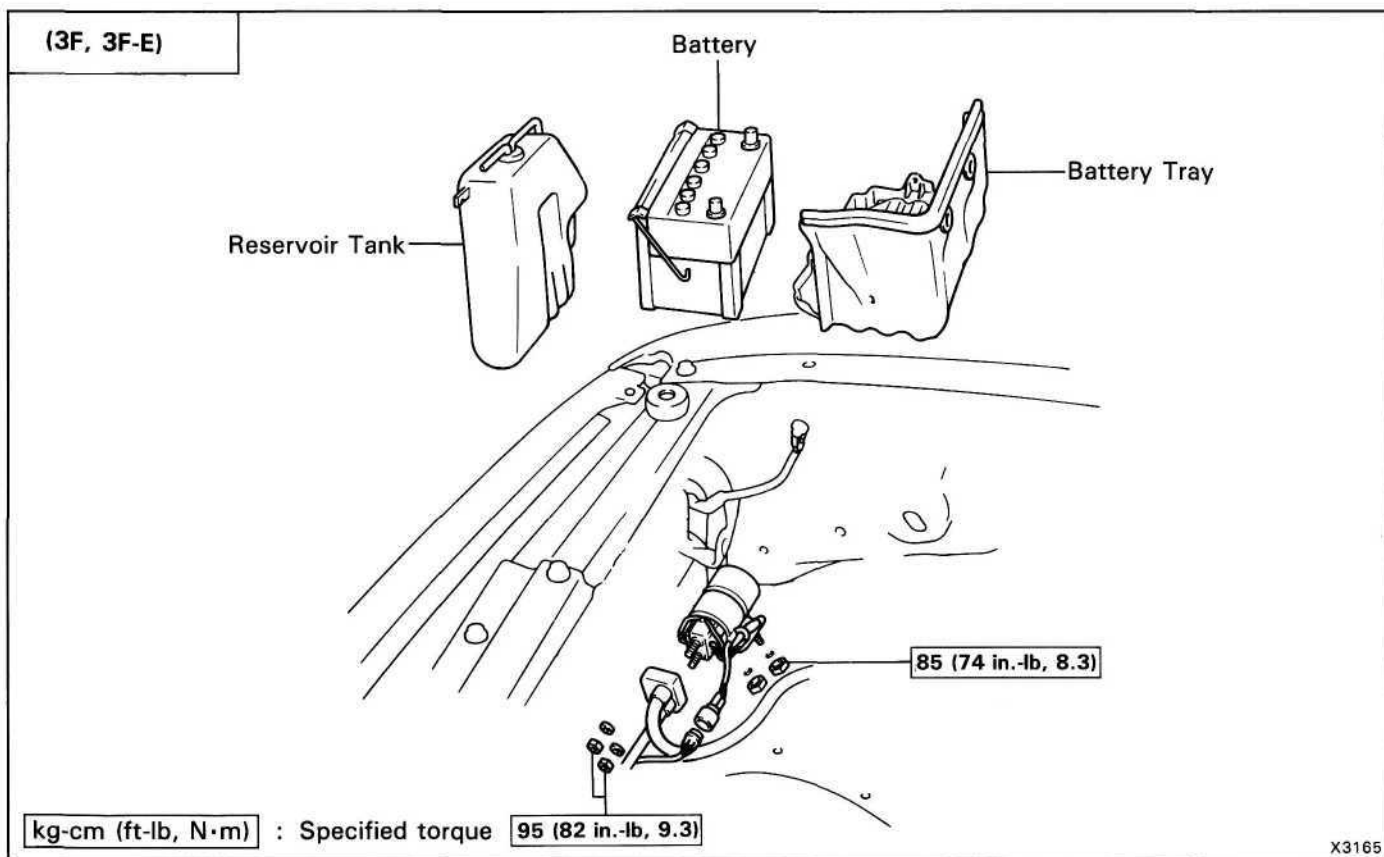
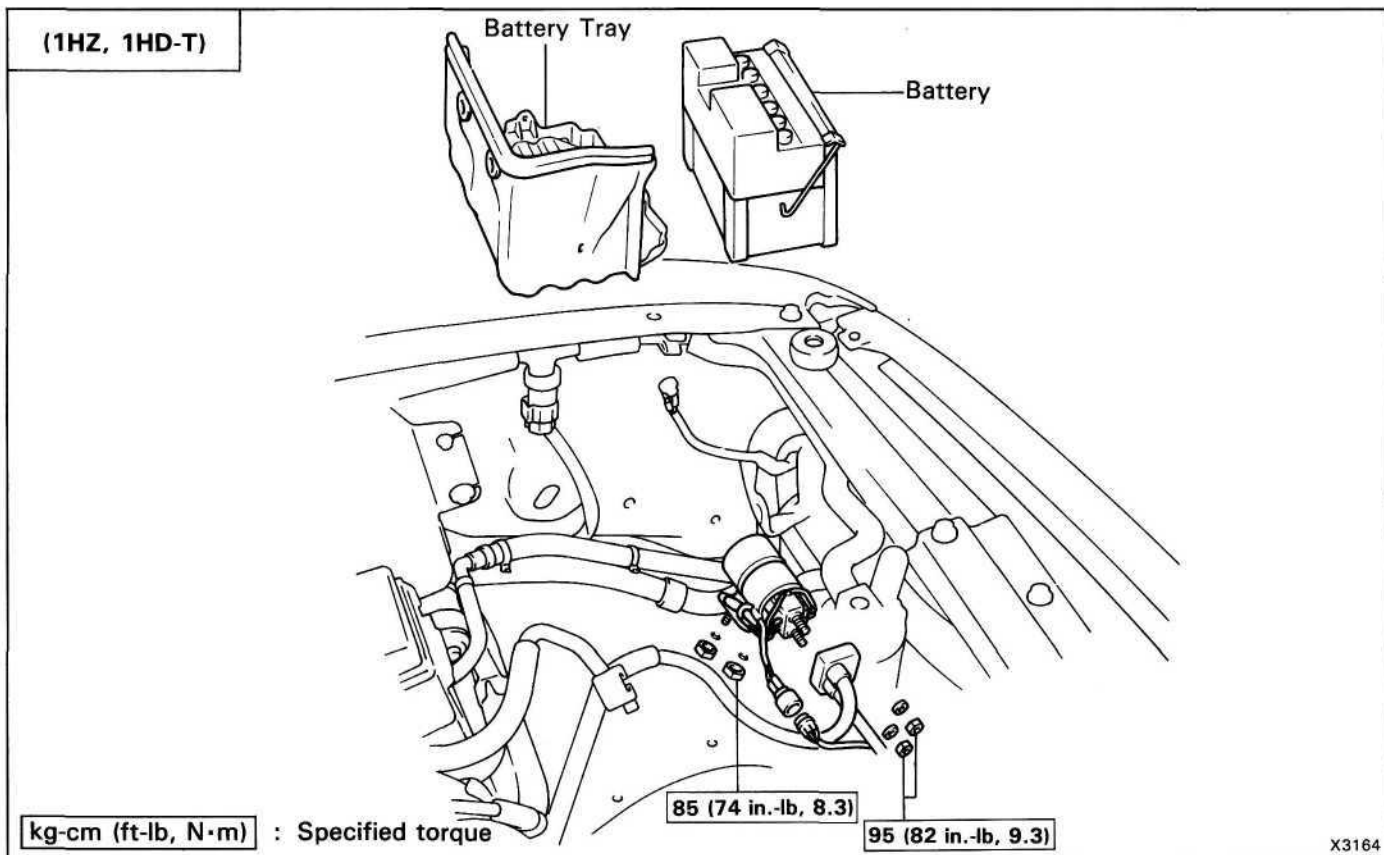

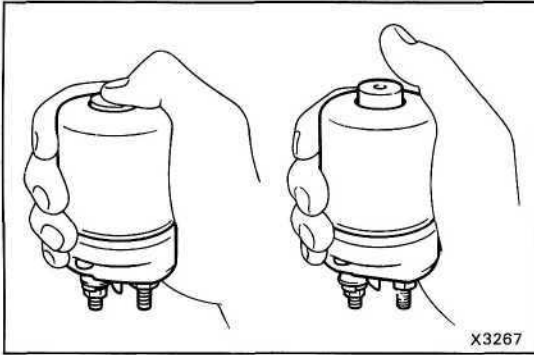

## INSPECTION OF MAGNET SWITCH NO.1

### INSPECT MAGNET SWITCH NO.1

- (a) Push in the plunger and release it. Check that it returns quickly to its original position.
- (b) Using an ohmmeter, check for continuity between the connector terminals.
- (c) Using an ohmmeter, check for no continuity between the terminals with the plunger released.

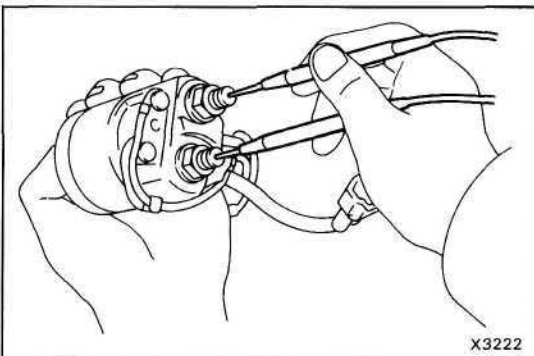
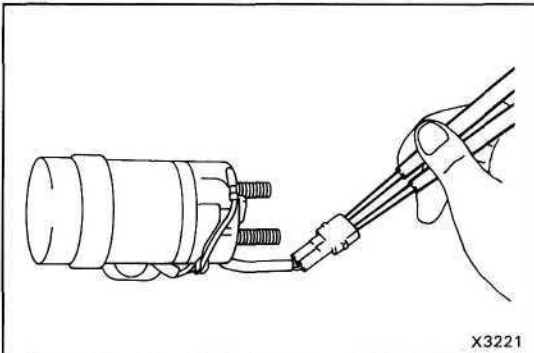

## Magnet Switch No.2 COMPONENTS

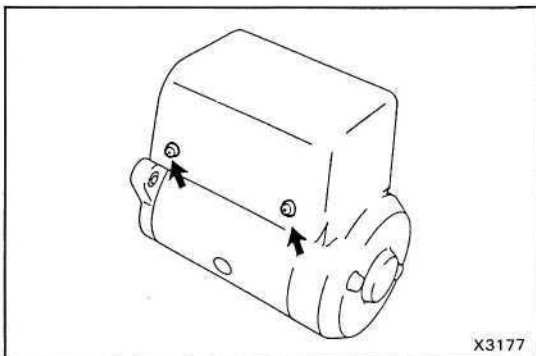
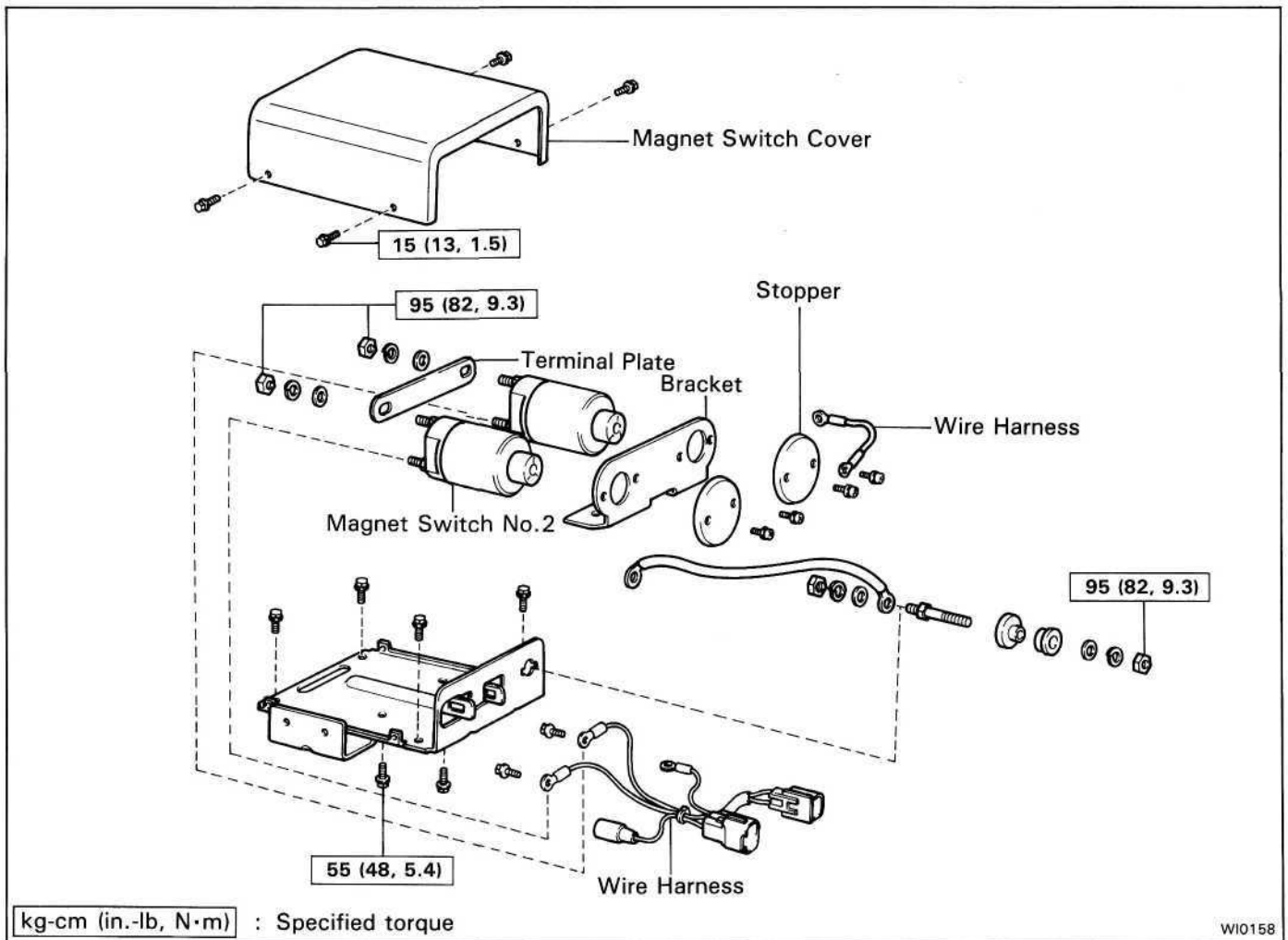

### DISASSEMBLY OF MAGNET SWITCH NO.2

#### 1. REMOVE MAGNET SWITCH COVER

Remove the four screws and the magnet switch cover.

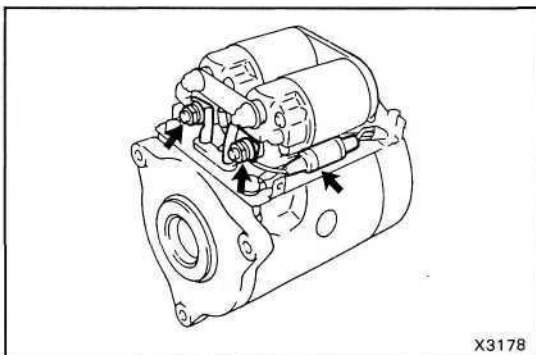

#### 2. REMOVE MAGNET SWITCH NO.2 ASSEMBLY

- (a) Disconnect the connector.
- (b) Remove the two nuts and the wire harness.

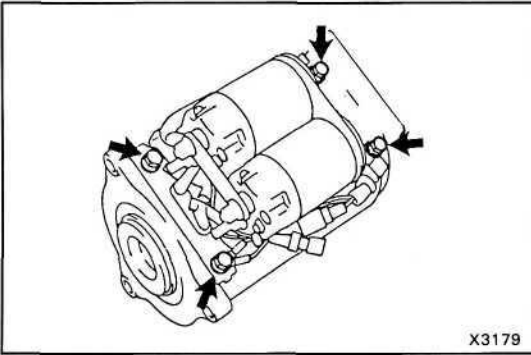

- (c) Remove the four bolts and the magnet switch No.2 assembly.

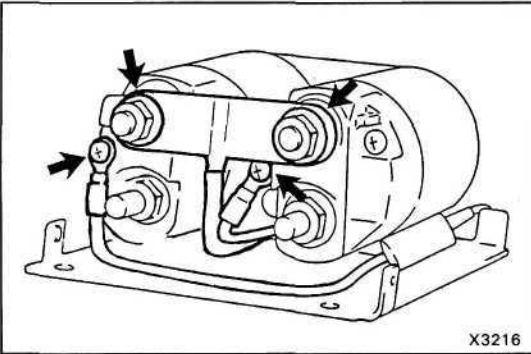

### 3. REMOVE MAGNET SWITCH NO.2

- (a) Remove the two screws, disconnect wire harness.  
 (b) Remove the two nuts and terminal plate.

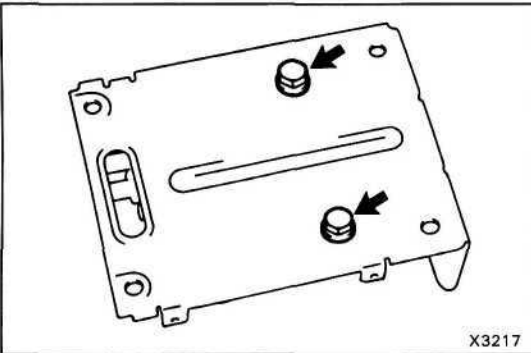

- (c) Remove the two bolts and the magnet switches.

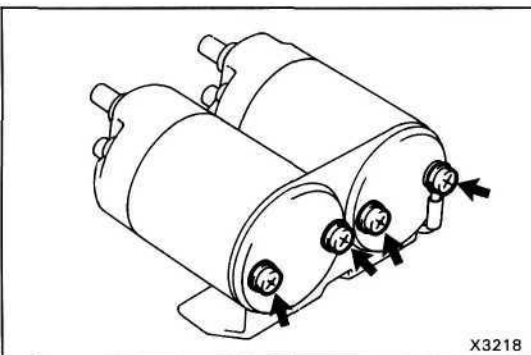

- (d) Remove the four screws, the bracket and the stoppers.

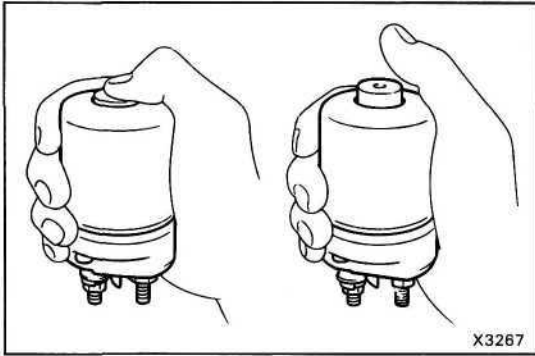

## INSPECTION OF MAGNET SWITCH NO.2

### 1. INSPECT MAGNET SWITCH NO.2

- (a) Push in the plunger and release it. Check that it returns quickly to its original position.

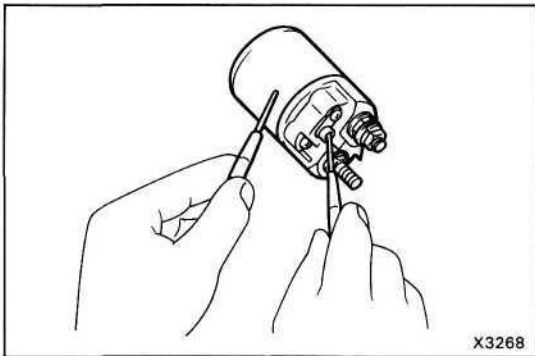

- (b) Using an ohmmeter, check for continuity between the base lead wire terminal and magnet switch body. If there is no continuity, replace the magnet switch.

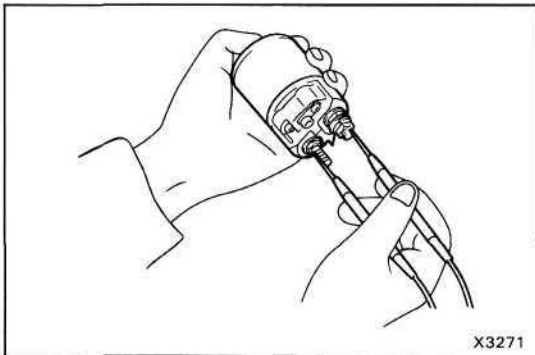

- (c) Using an ohmmeter, check for no continuity between the magnet switch terminal and the motor lead wire terminal with the plunger released.

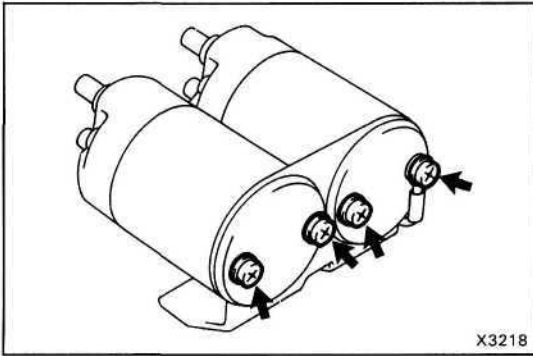

X3218

## ASSEMBLY OF MAGNET SWITCH NO.2

(See page WI-51)

### 1. INSTALL MAGNET SWITCH NO.2

- (a) Install the stoppers and the bracket with the four screws.

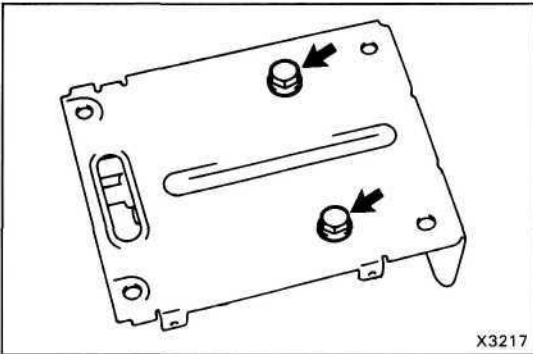

X3217

- (b) Install the two magnet switches with the two bolts.

**Torque: 55 kg-cm (48 in.-lb, 5.4 N-m)**

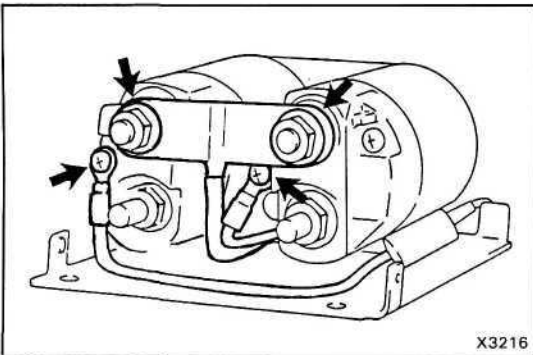

X3216

- (c) Install the wire harness with the two screws.

**Torque: 18 kg-cm (16 in.-lb, 2.0 N-m)**

- (d) Install the terminal plate with the two nuts.

**Torque: 95 kg-cm (82 in.-lb, 9.3 N-m)**

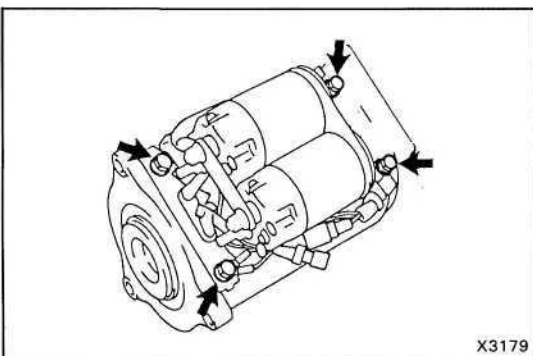

X3179

### 2. INSTALL MAGNET SWITCH NO.2 ASSEMBLY

- (a) Install the magnet switch to the winch motor assembly with the wire harness.

- (b) Torque the four bolts.

**Torque: 50 kg-cm (43 in.-lb, 4.9 N-m)**

- (c) Connect the connector.

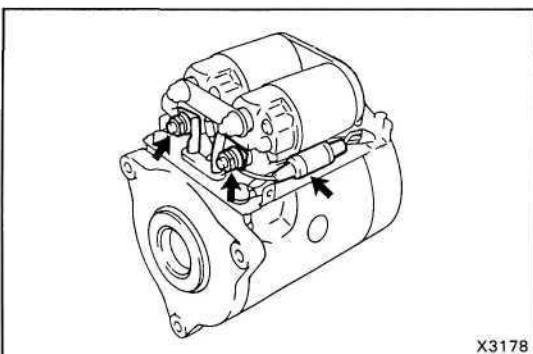

X3178

- (d) Install the wire harness with the two nuts.

**Torque: 95 kg-cm (82 in.-lb, 9.3 N-m)**

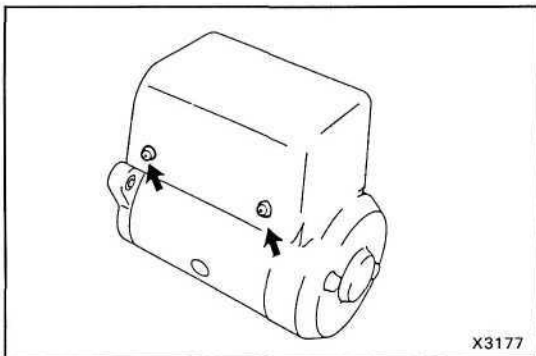

### 3. INSTALL MAGNET SWITCH COVER

Install the magnet switch cover with the four screws.

**Torque: 15 kg-cm (13 in.-lb, 1.5 N-m)**